

On a collection of geometrical riddles and their role in the shaping of four to six "algebras"

Høyrup, Jens

Published in:

Filosofi og videnskabsteori på Roskilde Universitetscenter, 3. række : Preprints og reprints.

Publication date:

1998

Document Version

Publisher's PDF, also known as Version of record

Citation for published version (APA):

Høyrup, J. (1998). On a collection of geometrical riddles and their role in the shaping of four to six "algebras". *Filosofi og videnskabsteori på Roskilde Universitetscenter, 3. række : Preprints og reprints.*, (2).

General rights

Copyright and moral rights for the publications made accessible in the public portal are retained by the authors and/or other copyright owners and it is a condition of accessing publications that users recognise and abide by the legal requirements associated with these rights.

- Users may download and print one copy of any publication from the public portal for the purpose of private study or research.
- You may not further distribute the material or use it for any profit-making activity or commercial gain.
- You may freely distribute the URL identifying the publication in the public portal.

Take down policy

If you believe that this document breaches copyright please contact rucforsk@ruc.dk providing details, and we will remove access to the work immediately and investigate your claim.

**ON A COLLECTION OF
GEOMETRICAL RIDDLES AND
THEIR ROLE IN THE SHAPING OF
FOUR TO SIX “ALGEBRAS”**

Jens Høyrup

**FILOSOFI OG VIDENSKABSTEORI PÅ
ROSKILDE UNIVERSITETSCENTER**

3. Række: Preprints og reprints

1998 Nr. 2

ISSN 0902-901X

Contents

Opening	1
A general characterization	3
“The four fronts and the area”, and its kin	8
An inventory – and a noteworthy discovery	16
Adoptions I: The scribe school	24
Adoptions II: Greek theory	32
Adoptions III: The proofs and associates of al-jabr	40
Adoptions IV: India	52
Al-jabr revisited	56
Closing	58
Bibliography	61

Opening

Scholars are human beings; in particular, we are readers and writers. As human beings we partake in the general weaknesses of the human race, one of which is the tendency to believe that the kind of thing we are doing is of extraordinary importance, for good or for evil; our particular dependence on the written word therefore often induces us to ascribe more absolute importance to this variety of *logos* than warranted – not least to the written words of identifiable scholars.

When historians of mathematics observe that closely related or identical problems turn up in the Chinese *Nine Chapters on Arithmetic* and in Diophantos's slightly later *Arithmetica*, the question that spontaneously presents itself to their mind is therefore whether Diophantos learned from the Chinese work, or it was the Chinese author who had access to a lost work written by a Greek mathematician and later also used by Diophantos. Even the very different methods used to solve the problems in the Chinese and the Greek work will not automatically make them (that is, us) doubt the basic model according to which knowledge stored in book form derives from other knowledge stored in a similar form.

Even when written sources refer rather explicitly to traditions whose use of books can be doubted, this is easily overlooked. A striking example is provided by the reading (or omitted reading) of Hero's *Metrica* I.xxx–xxxi [ed. Schöne 1903: 74]. Hero refers first to an otherwise unidentified group of people who “assume the perimeter of the circle to be the triple of the diameter”, and next to an equally unidentified group taking it to be “the triple of the diameter and the 7th part more”. The phrase is not the one which Hero himself uses elsewhere when finding the circular perimeter, nor is it certainly Archimedean. The only places where it will be found are in the conglomerates which collectively go under the name *Geometrica*¹ (and in the spurious prop. 2 of Archimedes's *Dimensio circuli* [ed. Heiberg 1880: I, 262]), and it is thus unambiguous evidence that the Archimedean approximation had spread into the anonymous environment of practical reckoners. Hero's own words notwithstanding, it is easy to find recent repetitions of Cantor's claim [1907: 548] that Columella must have learned from Hero, argued precisely from his sharing of this approximation with the Heronian (and, not distinguished, pseudo-Heronian)

¹ These conglomerates and the second-order conglomerate which Heiberg [1912] has produced from them are analyzed in [Høystrup 1997a]. As already pointed out by Heiberg [1914: xxi], the collections which he combines into one pseudo-Heronian treatise are of disparate character, and are “not made by Hero, nor can a Heronian work be reconstructed by removing a larger or smaller number of interpolations” (trans. JH).

writings. Similarly, when Solomon Gandz supposed to have arguments that the Hebrew *Mishnat ha-Middot* cannot be a translation from al-Khwārizmī's treatment of geometry in his *Algebra*, he jumps [1932: 63f] to the conclusion that al-Khwārizmī must have used the Hebrew treatise (in Syriac or Persian translation) as his model; even that “native popular science” of which he takes it to be a representative is thus defined not only as a *book* but as a *book which is known to us*.^[2] Similar examples abound, also in writings from the latest decades.

It is my claim that such conclusions are not only arbitrary but often demonstrably wrong, and that the knowledge of pre-modern practical professions was mostly not transmitted in books that we know about. The knowledge in question may have been regarded as craft secrets – but if so, we may be fairly sure that these secrets were not considered as esoteric knowledge. As observed by Neugebauer [1975: 566],

we know well how “secrets” were kept from the time of the Pyramid Texts in the Old Kingdom to the Jewish Kabbala in the Middle Ages: all these “secrets” were eagerly written down and have survived in countless copies and in an enormous variety of forms: the “spells” of the Egyptian literature for the use in the Nether World, the Greek magical papyri and the gnostic texts, the secrets of Nechepso-Petosiris and of Hermes Trismegistos, the Jewish and Christian “secret” names of God, of saints and demons in all Semitic tongues, the maulets and curses – nothing is less secret than “secret” literature.

“Practical professions” is a notion that covers many diverse activities with appurtenant domains of knowledge, not only today but at least since the great Bronze Age cultures. *Mutatis mutandis*, much of my general thesis will arguably hold broadly, but I shall concentrate on mathematical practice. For brevity I shall permit myself to speak of the practitioners as members of “professions”, “professional groups” and “crafts” as if these were well-defined entities; the reader should keep in mind, however, that we rarely possess much information about the precise social organization of carpenters, glass-makers, surveyors, etc. All we know for sure is that they were specialists, and must have possessed *some* social organization that was able to carry their professional knowledge and activity.

Even “mathematical practice” is far from uniform, but always tends to be the preserve of the few to a much larger extent than implied by the pervasive reference to “popular traditions”. Already the beautiful mural paintings of southern Africa, with their sophisticated multiple symmetries (involving both geometry proper and interchange of colours), though produced by the whole community of village women

² Whether Gandz's arguments are good or bad is immaterial in the present context. Personally I find it obvious from comparison of the two texts that neither depends on the other, but that the Hebrew treatise is closer to the common stock of traditional geometrical knowledge than al-Khwārizmī – but this opinion is not undisputed, see, e.g., [Lévy 1995: 139], based on Gad Sarfatti's publications in Hebrew.

according to principles that are considered general “secrets of women”, are in fact planned by a specialist-member of this community.^[3] When it comes to the mathematical techniques and knowledge of genuine professions, for instance of surveyors, architects, taxation officials and accountants, these were certainly no less practical secrets than the knowledge of a modern engineer or computer technician, and had no need of being understood as esoteric in order to deserve that status.

A general characterization

Before investigating a particular case, I shall summarize some of the general characteristics of the mathematical knowledge of pre-Modern practical professions; for fuller treatment and exemplification I shall refer to earlier publications of mine.^[4]

Not least when mathematical practice is concerned will it be important to distinguish two (ideal) types: one carried by a school institution, and one taught “on the job”, in a master-apprentice-system. Both types, of course, find their ultimate legitimacy in the world of *know-how*, not that of *know-why* (the world of “productive”, not that of “theoretical knowledge”, in Aristotle’s terminology). But a knowledge system, if existing as a system, has to be taught and not only to be used; and inasmuch as it is carried by a particular social group it will also serve to identify this group. Both in their relation to teaching and with regard to professional identification, the “scholasticized” and the apprentice-ship-based system differ fundamentally. We shall start by looking at the latter type, for which I have suggested the label “sub-scientific” rather than “popular” or “folk”;^[5] afterwards, we shall confront the transformation which practitioners’ knowledge undergoes when transmitted through a school.

In the pre-Modern world, proper schooling was mostly the privilege of the few. Some members of crafts that did not transmit their knowledge through a school system may still have been literate or semi-literate (not least in cultures like Islam, where elementary Koran reading was expected to be part of the religious education of boys); as a rule, however, the *culture* of such crafts will have been of the oral

³ [Gerdes 1996: 98, 176], partly citing Annice Changuion.

⁴ In particular [Høystrup 1990b; 1997b].

⁵ The purpose of the term is triple. Firstly, it should recall that the kind of knowledge involved is not a possession of everybody; secondly, it should suggest that this “almost-scientific” knowledge is still different in character from a body of scientific knowledge *stricto sensu*; thirdly, that it has often served as a foundation or starting point for the creation of scientific knowledge systems.

type.^[6] A first and obvious effect of this is that we have no direct sources for their knowledge, only indirect references and a small number of works written by authors actively engaged in transferring the knowledge in question from the orally based to the literate domain. The situation is parallel to the way we ascertain the presence of wonder tales in the oral culture of the ancient world: for instance from Apuleius's use of their familiar structure and motifs for a different and very literate purpose in his tale of Amor and Psyche, and from his presentation of the tale as an "old women's fable".^[7] Another effect of the underlying oral culture, of no less consequence for the present study, is the creation of a characteristic type of "supra-utilitarian" knowledge.

The larger part of the fund of knowledge of a practitioners' craft is evidently meant to serve its daily routines. At this level, the technical problems encountered in everyday are primary, and the methods ancillary, invented in order to solve these problems. Teaching already offers a slightly different case: here, the transmission of methods is primary, and some tasks may serve simply to train the methods; but as long as teaching is effected as *training of apprentices* and thus embedded in the activity of a "shop", there is a natural tendency to train as much as at all possible on practically (that is, economically) useful tasks. No strong incentive for going beyond the utilitarian level is likely to present itself in the context of training.

The supra-utilitarian level, instead, is important for the function of the knowledge system as an ingredient of craft identity. Knowledge that identifies the craft must certainly be, *or at least appear to be*, relevant for the activity of the craft – a characterization of Nietzsche as "the best composer among the philosophers and the best philosopher among the composers" could only be meant to as an insinuation that he be second-rank on both accounts. But at least for members of the craft, familiarity with the all-too-familiar basic professional tools is not sufficient to support professional pride. For this purpose, *virtuosity* in the handling of the tools is needed; this is displayed as the ability to deal with problems that are more difficult than those encountered in everyday but which are still related in kind to utilitarian tasks, that is, which can be characterized as *supra-utilitarian*. In mathematics, these problems are known as *recreational problems*.

Since the function of the supra-utilitarian knowledge is to display proficiency in the handling of methods, the methods are primary and the problems for whose solution they serve become secondary on this level of knowledge. In so far, recreational problems belong to the same breed as the Eiffel Tower, built with the

⁶ For analysis of the distinctive characteristics of this cultural type, one may consult various writings of Walter J. Ong [e.g., 1967; 1982] and Jack Goody [e.g., 1968; 1977; 1987].

⁷ *Metamorphoses* IV.27, ed. [Terzagi 1983: 100].

sole purpose of showing which miracles late nineteenth-century engineering could perform in iron constructions. Further, since this function is accomplished within an oral culture, they take on the same form as other tests of the right to enter a specific place, environment or group: They are *riddles*, but certainly meant not for entertainment but as challenges^[8] – less deadly than the riddle of the Sphinx, but belonging to the same kind as this “neck riddle”.

Qua riddles, the “recreational problems” share several features with other riddles. First of all, the formulation of a recreational problem is always somehow striking, as it befits a riddle – at times it is directly absurd. This depends on two factors; on one hand, the question should kindle interest or curiosity in order to serve as a worthwhile challenge. On the other, a formulation which is not stunning will easily mutate during oral transmission, but only until the point when somebody finds a formulation which *is* stunning – for instance, that one hundred monetary units buys exactly one hundred animals; then the formulation freezes.

Next, it is only true to a certain point that the problems are determined from the stock of available methods. At times, solution presupposes the application of a particular trick which has no practical use, but which of course, when handed down together with the riddle, becomes part of the stock of available techniques known by members of the profession. One example is found as No. 52 (version II) in the Carolingian problem collection *Propositiones ad acuendos iuvenes*, in which a camel seems to devour exactly *everything* during a transportation of grain.^[9] Another example is the quadratic completion of mixed second-degree area problems, which we shall encounter below.

At times, the trick is mathematically wrong, and the problem possesses no proper mathematical solution at all (a feature which is particularly puzzling if we try to understand the problems as *mathematics* in the genuine sense); this is the case in No. 6 of the same collection, where swines are sold at the price they are bought for, but apparently with a profit. What is requested is in fact an answer in agreement with the established canon of the group, as proof of familiarity with this canon – and

⁸ See, beyond the references in note 6, [Koch 1995] and [Pucci 1997: 59–63 and *passim*].

⁹ “A paterfamilias had a distance from one house of his to another of 30 leagues, and a camel which was to carry from one of the houses to the other 90 measures of grain in three turns. For each league, the camel would always eat 1 measure. Tell me, whoever is worth anything, how many measures were left” [ed. Folkerts 1978: 74, trans. JH]. The trick consists in a stop and return after 20 leagues, which allows a net transfer of grain. The solution is not optimal, a first stop after 10 leagues and a second after another 15 would be more efficient. The text illustrates both the predilection for the absurd – exactly *everything* seems to be consumed – and the function of the problem as a test of appurtenance to the community of competent reckoners who are “worth anything”.

only because the group is demarcated by exercising a mathematical practice will this canon *on the whole* but not exclusively be mathematical. This sometimes oblique character of the answer is no different from what we encounter in other riddles, the solutions to which are rarely straightaway answers – we may think again of the riddle of the sphinx, the answer to which transposes “morning”, “noon” and “evening” into “childhood”, “adult age” and “evening of life”.

In an institutionalized school, teaching is taken care of by teachers who have this chore as their main activity, and not the genuine professional use of the tools which they transmit. The work of students, on its part, is of no direct use, it *only* serves training purposes. For both reasons, even the training of elementary abilities may make use of problems which are not directly relevant for professional practice, and which are thus secondary with respect to the methods they should teach;^[10] in this respect they will be similar to the recreational problems. But whereas riddles tend to exist in one or a few authorized versions, the number of similar elementary training problems in a school will tend to grow by simple variation, in which process any striking character of problems is easily lost.

Genuine “recreational” problems still have their place in school teaching; they provide some diversion in the tedium of simple variation of elementary training problems, as argued by Pier Maria Calandri in his fifteenth-century *Tractato d’abbacho* [ed. Arrighi 1974: 105, trans. JH]:

I believe for certain that the human intellect, using always the same thing, may occasionally be disgusted with it however enjoyable it be; and in order not to end up in this trouble in the beginning of our working, in the present chapter some pleasant problems will be dealt with.

It is thus precisely in the school context (and in literate use) that the “recreational” problems come to deserve their name.

Even the recreational problems, however, will be affected by the school context, and tend to be appear in many variations. This may be illustrated by the way the Italian *scuola d’abbaco* presents us with the problem of the “hundred fowls”: both the quantity of money and the number of animals may vary. (Below, the transformation of the “surveyors’ riddles” into “algebra” will provide us with a historically more consequential example.)

If one school tradition borrowed directly from another, there would be no

¹⁰ For reasons of pedagogical efficiency, training will still be based on *problems*, not on the explanation of theory or abstractly formulated rules. It is striking that all mathematical texts from the Old Babylonian school that try to formulate a general rule are close to the oral tradition (see below, note 50 and preceding text); with the maturation of the school tradition, these attempts were given up – see [Høyrup 1998: 148].

particular reason that precisely the striking version should be the one which was invariably shared; the fact that the various school traditions have, for instance, precisely “100 animals for 100 units” in common demonstrates that the diffusion has taken place at the level of oral riddles, from which all the school traditions from “Ireland to India”^[11] have taken their inspiration, and which has provided the starting point for the particular pattern of variation of the single school system (for instance, that the Indian version normally involves four instead of three species).

“The four fronts and the area”, and its kin

The rest of the article will investigate a case of particular importance for the development of high-level mathematics in a variety of cultures and thereby – this is the intention – illuminate the applicability of the preceding general statements.^[12] The starting point is problem No. 23 from the Old Babylonian text BM 13901 [ed. Neugebauer 1935: III, 4f, trans. JH]:^[13]

⟨If somebody asks you thus⟩ about a surface: the four fronts
and the surface I have accumulated, 41°40′.
4, the four fronts, you inscribe. The reciprocal of 4 is 15′.
15′ to 41°40′ you raise: 10°25′ you inscribe.
1, the projection, you append: 1°10′25″ makes 1°5′ equilateral.
1, the projection, which you have appended, you tear out: 5′
to two
you repeat: 10′ NINDAN confronts itself.

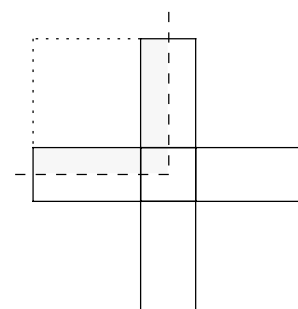

Figure 1. The method of BM 13901 No. 23.

The diagram illustrates the way the problem is solved:^[14] The four “fronts” or sides (*s*) are represented by four

¹¹ A chapter heading from Stith Thompson’s renowned book on another aspect of oral culture [1946: 13].

¹² The basis for the case is presented in [Høystrup 1996a]. Unfortunately the publishers of the volume (the Mathematical Association of America) supposed proof reading to be superfluous, for which reason at least my contribution abounds with printing errors, mostly due to faulty computer conversion and ensuing equally poor repair. A somewhat different presentation in French is [Høystrup 1995], which however (for identical reasons) is even more defective (some 12 errors per page, including an omitted passage of 457 words); the latter version was republished in corrected form as [Høystrup 1996b].

¹³ I follow Thureau-Dangin’s degree-minute-second notation for sexagesimal numbers; 1°10′25″ thus stands for $1 + \frac{10}{60} + \frac{25}{60 \cdot 60}$.

¹⁴ The reasons that the Old Babylonian “algebra” texts must be understood in agreement with their geometrical wording (and lengths and areas thus not as metaphors for abstract numbers and their products) are set forth in detail in [Høystrup 1990a].

rectangles $\square(1,s)$ which stick out from the square surface $\square(s)$;¹⁵ the total area of this configuration is hence $41'40''$. A quarter of this configuration (dotted in the diagram) is a gnomon with area $10'25''$; it is completed by adjunction of a square $\square(1,1)$ as another square $1^\circ10'25''$, whose side is $1^\circ5'$. Removing the adjunction we are left with $5'$ as the halved side of the original square, which is doubled and then told to be $10'$ NINDAN (1 NINDAN \approx 6 m).

All problems on the tablet deal with one or more squares – in the terminology introduced by Jöran Friberg, the text is a “theme text”. In symbolic translation, they may be represented thus (Q stands for the quadratic area, s for the side; the unit is always understood to be the NINDAN):

1. $Q+s = 45'$
2. $Q-s = 14'30$
3. $Q-\frac{1}{3}Q+\frac{1}{3}s = 20'$
4. $Q-\frac{1}{3}Q+s = 4'46'40'$
5. $Q+s+\frac{1}{3}s = 55'$
6. $Q+\frac{2}{3}s = 35'$
7. $11Q+7s = 6^\circ15'$
8. $Q_1+Q_2 = 21'40''$, $s_1+s_2 = 50'$ (reconstructed)
9. $Q_1+Q_2 = 21'40''$, $s_2 = s_1+10'$
10. $Q_1+Q_2 = 21^\circ15'$, $s_2 = s_1-\frac{1}{7}s_1$
11. $Q_1+Q_2 = 28^\circ15'$, $s_2 = s_1+\frac{1}{7}s_1$
12. $Q_1+Q_2 = 21'40''$, $\square(s_1,s_2) = 10'$
13. $Q_1+Q_2 = 28'20''$, $s_2 = \frac{1}{4}s_1$
14. $Q_1+Q_2 = 25'25''$, $s_2 = \frac{2}{3}s_1+5'$
15. $Q_1+Q_2+Q_3+Q_4 = 27'5''$, $(s_2,s_3,s_4) = (\frac{2}{3},\frac{1}{2},\frac{1}{3})s_1$
16. $Q-\frac{1}{3}s = 5'$
17. $Q_1+Q_2+Q_3 = 10'12^\circ45'$, $s_2 = \frac{1}{7}s_1$, $s_3 = \frac{1}{7}s_2$
18. $Q_1+Q_2+Q_3 = 23'20''$, $s_2 = s_1+10'$, $s_3 = s_2+10'$
19. $Q_1+Q_2+\square(s_1-s_2) = 23'20''$, $s_1+s_2 = 50'$
20. [missing]
21. [missing]
22. [missing]
23. ${}_4s+Q = 41'40''$
24. $Q_1+Q_2+Q_3 = 29'10''$, $s_2 = \frac{2}{3}s_1+5'$, $s_3 = \frac{1}{2}s_2+2'30''$

No. 23 is the only conserved problem that indicates the unit, but this is merely one of many features that set it apart. It is found in a part of the text where all other problems treat of several squares; it is the only square problem in the whole Old Babylonian corpus to speak of the sides before the area (and to use a specific phrase that points to *the* four sides, rendered symbolically as ${}_4s$); with one exception to which

¹⁵ The “projection” is that breadth 1 which transforms a line of length s into a rectangular area with the same numerical value.

we shall return it is alone in speaking of the side of the square as a “front” (moreover, it does so in syllabic Akkadian, whereas normal “algebra” texts using this term about the short side of a rectangle invariably use a Sumerian word sign¹⁶); and it uses a trick which depends critically on the “coefficient” 4, whereas all other solutions (except nos 9 and 10, where the question does not present itself) are obtained by means of coefficient-independent techniques. The problem is indeed so aberrant that Neugebauer proposed it to be the outcome of a scribal confusion that happens to make mathematical sense.

When Neugebauer did so, nobody had observed that the problem is quite widespread and therefore not to be explained away; it is indeed as characteristic and hence as good an index fossil as are trilobites for the Cambrian and immediately following periods in palaeontology. The next occurrence which I know of is in a treatise which Heiberg included as chapter 24 in the second-order conglomerate referred to above (the *Geometrica*, see note 1), known from the Codex Constantinopolitanus Palatii Veteris No. 1:¹⁷

A square surface having the area together with the perimeter of 896 feet. To get separated the area and the perimeter. I do like this: In general [καθολικῶς, i.e., independently of the parameter 896 – JH], place outside (ἐκτίθημι) the 4 units, whose half becomes 2 feet. Putting this on top of itself becomes 4. Putting together just this with the 896 becomes 900, whose squaring side becomes 30 feet. I have taken away underneath (ὕφαρπέω) the half, 2 feet are left. The remainder becomes 28 feet. So the area is 784 feet, and let the perimeter be 112 feet. Putting together just all this becomes 896 feet. Let the area with the perimeter be that much, 896 feet.

(the diagram follows the description of the procedure as given in the text, including

¹⁶ Sumerian had been the dominant language in southern Iraq in the third millennium BC; Akkadian, a Semitic language (which is split into a Babylonian and an Assyrian dialect in the second millennium), was present in the area already by then and was written from c. 2500 BC onward; in the second millennium, it was the main spoken and written language of Babylonia. In Sumerian, semantic cores were mostly written by means of word signs, whereas grammatical complements had to be expressed in syllabic writing. In principle, Akkadian is written syllabically, but Sumerian word signs may be used for the roots of words (and may or may not be provided with phonetic complements, at times instead with Sumerian grammatical complements). In mathematical texts, a few terms (the length, width and area of “abstract” rectangles, square and cube roots, the terms for the reciprocal and for multiplication of number with number) are invariably written with Sumerograms – roots and reciprocal sometimes in syllabic writing of the *Sumerian term*, obviously used as a loan word; most terms, however, in particular the characteristic vocabulary of the “algebra” and the length and width (“front”) of real fields, are often written in syllabic Akkadian.

¹⁷ *Geometrica* 24.3, ed. [Heiberg 1912: 418], trans. JH. This manuscript (“S”) also contains Hero’s *Metrica* and one of the two main constituents of Heiberg’s construction (the other being constituted by mss A+C); however, chapter 24 is an independent piece.

the orientation; the diagram in the manuscript only shows the square).

In a *Liber mensurationum* written by an otherwise unidentified Abū Bakr^[18] and known from Gerard of Cremona’s Latin translation. Its problem 4 – dealing with an “equilateral and right quadrangle” – looks as follows:^[19]

And if he [a “somebody” introduced in No. 1] has said to you: I have aggregated its 4 sides and its area, and what resulted was hundred and 40, then how much is each side?

The working in this will be that you halve the sides which will be two, thus multiply this by itself and 4 result, which you add to hundred and <forty, and what results will be hundred and 44, whose root you take which is 12, from which you subtract the half of four, what thus remains is the side which is ten.

In Savasorda’s early twelfth-century *Liber embadorum*, the following is one of a group problems on squares and rectangles which (as Savasorda tells) serve no practical purpose but will allow the reader to display his ability:^[20]

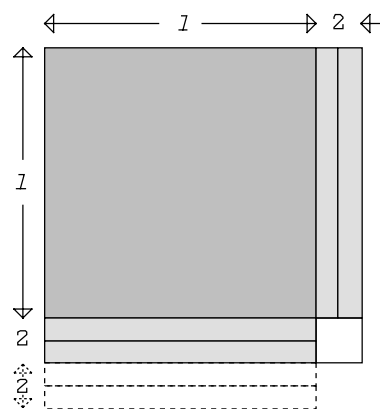

Figure 2. The method described in *Geometrica* 24.3.

¹⁸ The name does not help us to identify the author; since Abū Bakr was the name of the first caliph, it is simply too common (so to speak the Giovanni/Jean/Hans/Juan/John of Sunni Islam). Since the treatise is characterized by a conscious effort to merge different traditions (cf. note 19), it is no likely to be much earlier than the early ninth Century CE; certain features of the terminology, on the other hand, will have been archaic (but not impossibly archaic) if the treatise postdates al-Khwārizmī’s *Algebra* considerably. Whatever the actual date of composition, it reflects the status of c. 800 CE.

¹⁹ Ed. [Busard 1968: 87], trans. JH. Not in the present case but for many of the other problems Abū Bakr offers alternative solutions by means of *al-jabr* (rendered as *aljabra* by Gerard). The synthesis of two approaches is typical of what happened in Islamic mathematics in the ninth century and a main reason not to date Abū Bakr much before that epoch; but apart from that the *al-jabr* solutions are not relevant in our present context. As Abū Bakr sees it, the staple method for problems of this type is evidently the one he uses in the present case. He only presents the solutions as algorithms without argument, but a couple of erroneous shortcuts (in No. 38 and 46) shows that the procedures presuppose a geometry of the kind shown in Figure 2.

²⁰ Trans. JH from Plato of Tivoli’s Latin version [ed. Curtze 1902: 36]; the modern translation into Catalan [ed. Guttman, trans. Millàs y Vallicrosa 1931: 37] is very similar, but its “meitat del nombre dels costats” where Plato has the usual “dimidium suorum laterum” shows the translation to be less accurate than Plato’s version; so does the free translation “elevant al quadrat”. In any case, it is prudent always to look at both versions, since Plato’s goes back to another Hebrew recension than the Guttman edition (Tony Lévy, private communication).

If, in some square, when to its surface is added the sum of its four sides, you find 77, how many cubits are contained in the surface? Taking the half of its sides, which is two, and multiplying it with itself, you find 4. If you add this to the given quantity, you will have 81; when you take its root, which is 9, and when you subtract from this the half of the addition that was mentioned already, 7 remain. This is the side of the square in question, whose surface contains 49.

Not only the numerical values but also comparison of the surrounding sequence of problems with the corresponding sequence in the *Liber mensurationum* shows beyond reasonable doubt that Savasorda does not draw directly on Abū Bakr.

Leonardo Fibonacci, in the *Pratica geometrie*, has the same numbers as Abū Bakr; but he “normalizes” the order of area and sides so as to make it coincide with the algebraic canon (the problem serves as his paradigm for the type “square plus sides equal number”), and like the Greek specimen he wants to “separate” the constituents of the sum:^[21]

And if the surface and its four sides make 140, and you want to separate the sides from the surface. [...].

In Piero della Francesca’s *Trattato d’abaco* we find still another version:^[22]

And there is a square whose surface, joined to its four sides, makes 140. I ask what is its side. [...].

Once again, not only the actual words but also the context shows that Piero’s reference is not Fibonacci (nor Abū Bakr/Gherardo, nor Savasorda).

Finally, Luca Pacioli’s *Summa de arithmetica* from 1494 has the following formulation:^[23]

And if the 4 sides of a square with the area of the said square are 140. And you want to know how much is the side of the said square. [...].

The proof follows Fibonacci closely; the distinct statement (and in particular the return to the traditional order where the sides precede the area, certainly not what any Italian abacist trained in algebra would invent on his own) thus shows that

²¹ Ed. [Boncompagni 1862: 59], trans. JH. The proof seems to be of Fibonacci’s own making. Elsewhere he follows Abū Bakr word for word when using him; the present deviations therefore show that his source for the actual problem was different (and his use of the traditional notion of separation – also found in certain Old Babylonian texts – shows that he did copy from a source).

²² Ed. [Arrighi 1970: 122], trans. JH. I am grateful to Luis Radford for having first directed my attention to this occurrence of the problem.

²³ [Pacioli 1523: II, fol. 15r], trans. JH.

even Pacioli has access to the tradition through at least one more channel.^[24]

Most of these texts contain other problems that refer explicitly to “all four sides” of squares or rectangles (or “both sides” of a rectangle, i.e., length and width): area equal to “all four” (or “both”) sides, area minus all sides equal to a given number, etc. Problems that involve the equality of all sides and the area are also present or referred to in a few other texts: The Old Babylonian problems AO 8862 No. 4 and AO 6770 No. 1 (length and width equal to rectangular area);^[25] Mahāvīra’s *Gaṇita-sāra-sangraha* VII, §§ 113§ and §115½ (square and rectangular perimeter equal to the area);^[26] finally, the pseudo-Nichomachean *Theologumena arithmeticae* mentions that the square $\square(4)$ is the only square that has its area equal to the perimeter, whereas Plutarch refers to Pythagorean knowledge of the equality of area and perimeter in the rectangle $\square(3,6)$.^[27]

Apart from the Old Babylonian tablet BM 13901 and a marginal exception in Leonardo’s *Pratica*, none of these texts explore problems that involve “non-natural” coefficients – as, for instance, “ $\frac{2}{3}$ times the area plus $\frac{1}{3}$ of the side of a square equals 20” (BM 13901 No. 3). The constant reference to the striking (and the absence of systematic variation^[28]) is characteristic of riddles and a contrast to the customs of school systems. Most if not all of the texts are of course connected to school

²⁴ Most likely, this access is through the (so far unpublished) fifteenth-century Italian version of Fibonacci’s *Pratica* on which Pacioli drew – cf. [Picutti 1989].

²⁵ Ed. [Neugebauer 1935: I, 111; II, 37, III, 62f]. Like BM 13901 No. 23, the latter problem is not formulated in the standard terminology of the school texts; moreover, it expresses an opaque general rule instead of solving a paradigmatic example. As a result, its precise interpretation is still undecided; the only reading which is not forthright impossible from a terminological point of view (pace Bruins [1968], Brentjes & Müller [1982], etc.) is the one which was first proposed by Solomon Gandz [1948: 38] and made more widely known by van der Waerden [1962: 73f].

A number of other Old Babylonian texts deal with the sum of a rectangular area and length plus width.

²⁶ Ed., trans. [Rāṅgācārya 1912: 221]. Elsewhere (VII, § 129½, p. 224), Mahāvīra treats the case where the rectangular area and perimeter are given separately.

²⁷ *De Iside et Osiride* 42, cited from [van der Waerden 1979: 401]. A generalized and arithmeticized version of the problem (to find two numbers whose product has a given ratio to their sum) turns up in Diophantos’s *Arithmetica* as I.14, II.3 and lemma to IV.36. The corollary to I.34 refers to the corresponding determinate problem where the ratio between the numbers is also given.

²⁸ – or absence of variation at all: Piero gives the problem ${}_4s-Q = \alpha$ twice, once to illustrate an algebraic rule, and once under geometry; words and grammar are slightly different, but α remains 3 [ed. Arrighi 1970: 133, 177]; the same value is used by Fibonacci and Pacioli, in words which differ enough to exclude copying.

traditions of some kind, and they contain other material which is not common property; but as in the case of the “100 fowls”, the shared striking structure indicates that they draw on a common riddle tradition of oral cultural type rather than being directly connected (apart from the obvious but not all-explaining connections between some of the Italian treatises).

If we see what other problems turn up regularly in the company of the “four sides”, we may identify the main carrier tradition for the riddle (certainly a tradition with branchings): a heritage of practical geometers (surveyors rather than architects) diffusing from the Near East, probably with its original centre in the Syro-Iraqi-Iranian area. Here it provided the starting point for the creation of Old Babylonian school algebra. Perhaps already during the Assyrian or Achaemenid conquests, perhaps only in Hellenistic times, a characteristic variant reached Egypt; in a way which we cannot trace *the same variant* reached India – quite likely by way of the Jaina, since Mahāvīra belongs to this group. A type which may be closer to the original form was encountered by the Islamic mathematicians and borrowed from them by Savasorda, Fibonacci and the Italian *abbaco* mathematicians. A form close to the original type also provided inspiration for the metric geometry (the so-called “geometric algebra” of *Elements* II). The “four sides of the area” of our Babylonian text, instead of being a scribal mistake, turns out to be perhaps the single four most significant lines in the record of documents for the history of pre-Modern mathematics.

This accumulation of rash statements requires detailed arguments in order to be made credible. Space will only allow me to present some of them; others are discussed in the publications mentioned in note 12.

An inventory – and a noteworthy discovery

First of all it will be convenient, however, to inventory the stock of riddles which seems to have been carried by the tradition at least since the early second millennium BC. All recur in many of the texts mentioned above, or in others belonging to the same cultures and epochs. Some are so peculiar – either in their mathematics or in their formulation – that they are highly unlikely to have been invented independently in the various contexts where they turn up; others go so regularly together with the weird specimens that this can serve as an argument that even they have been transmitted and not reinvented by accident.

A crucial member of the group is of course the riddle of “the four sides and the square area”. As we shall see below, we may even assume with fair certainty that the solution was 10 originally, as still in the last occurrence (and that the sides were mentioned first). All in all, the following problems on a single square seem to have been present from an early date (“???” indicates doubt as to the date from

which the problem is present; d is the diagonal of the square; here and everywhere in the following, Greek letters stand for given numbers):

$$\begin{aligned}
 s+Q &= \alpha (= 110) \\
 {}_4s+Q &= \beta (= 140) \\
 Q-s &= \gamma \\
 Q-{}_4s &= \delta (???) \\
 s-Q &= \varepsilon \\
 {}_4s-Q &= \zeta (???) \\
 {}_4s &= Q \\
 d-s &= 4 (???)^{[29]}
 \end{aligned}$$

Most of these may be described as “quasi-algebraic”, because they were solved in analytical steps which may easily be translated into an algebraic procedure, even though the actual argument was based on the same kind of “naive” cut-and-paste geometry as illustrated in Figure 1 and Figure 2,^[30] the last problem, if indeed present as a “riddle”, is likely to have been answered from the known approximation.^[31]

²⁹ The problem $d-s = \rho$ is only found in the *Liber mensurationum*, where ρ is successively 4, 5 and 4, and with Fibonacci followed by Piero and Pacioli ($\rho = 6$). In Abū Bakr’s first instance, the exact solution is found ($s = 4+\sqrt{32}$; Fibonacci etc., also exact, find $6+\sqrt{72}$); Abub Bakr’s case $\rho = 5$ only refers to the preceding method; his third case only differs from the first by speaking of the excess of the diagonal over “each of the sides” and not of subtraction proper. This repetition of the same problem in versions which differ only in their choice of subtractive operation makes it unlikely that it was invented by the mathematician Abū Bakr; he will rather have taken over a familiar problem whose current solution is likely to have been derived from a practical assumption that the diagonal in the 10×10 -square is 14. This assumption may be as old as the routine reference to the square in question; but we have no means to know whether it served as the *pretext for a problem* much before Abū Bakr’s times.

³⁰ I use the term “naive” for an approach where the correctness of the steps is “seen” immediately, as opposed to a “critical” approach (the term taken in a quasi-kantian sense) which scrutinizes the *reasons why* and the *conditions under which* the procedure is valid.

³¹ It is not impossible, it is true, that further reflection on the problem can have led to discovery of the side-and-diagonal-number algorithm described by Theon of Smyrna [ed. trans. Dupuis 1892: 70–75], which *may* lay behind the true solution of the problem in the *Liber mensurationum*. The algorithm, as is well known, depends on the fact that if s and d are the side and diagonal of an isosceles right triangle, then $S = s+d$ and $D = 2s+d$ have the same property; then, indeed,

$D-S = s$, whence $d = \sqrt{2 \cdot (D-S)^2}$, and thus $S = s+d = (D-S) + \sqrt{2 \cdot (D-S)^2}$, as used by Abū Bakr.

Abū Bakr does not tell his argument. However, Fibonacci [ed. Boncompagni 1862: 62] gives an ingenious proof by means of area geometry which leads to the same formula, and which is so similar in style to the argument which appears to underlie other procedures of the *Liber mensurationum* (namely those that involve sides and diagonal in a rectangle) that it is likely to be the one on which Abū Bakr’s solution builds. The gist of the argument is

The following problems dealing with two squares will have circulated already in the early second millennium:

$$Q_1 + Q_2 = \alpha, s_1 \pm s_2 = \beta$$

$$Q_1 - Q_2 = \alpha, s_1 \pm s_2 = \beta$$

At least when the difference between the areas is given, the two squares were thought of as concentric (and the difference thus as the area of a quadratic border; the cuneiform text where they are contained give no solution, but in later (late classical and medieval) times the areas of such quadratic and circular borders were determined as the product of the “average length” (here $2s_1 + 2s_2$) and the width (here $(s_1 - s_2)/2$).^[32]

These problems dealing with a rectangle (length l , width w , diagonal d , area A) can be traced back to the same early epoch:

$$A = \alpha, l \pm w = \beta$$

$$A + (l \pm w) = \alpha, l \mp w = \beta$$

$$A = \alpha, d = \beta$$

Everything we may say about the beginnings of the tradition we are tracing depends on its interaction with the Mesopotamian scribe school (we shall return to the reasons that prevent us from identifying it directly with this school tradition). A hint which *possibly* suggests its existence already before 2500 BC is a school tablet from 26th-c. Šuruppak showing a configuration of four equal circles touching each other.^[33] The same configuration (not wholly idiosyncratic, nor however one that would automatically arouse attention in every geometrically interested environment) recurs not only in the Old Babylonian tablet BM 15285 but also in Mahāvīra’s *Gaṇita-sāra-sangraha* [ed., trans. Raṅgācārya 1912: 206], whose relevance for the investigation will be made clear below (p. 52 and *passim*); in Mahāvīra’s work, and probably in the somewhat damaged Old Babylonian specimen, the area of the enclosed space is asked for.

More firm evidence comes from the 22d c. BC. As pointed out by Robert M. Whiting [1984: 65f], the area problems in a school tablet from this outgoing “Old

precisely the drawing of a square with side D , partitioned as $s+s+d$, and the proof that both pairs (s,d) and $(S = s+d,D)$ are side and diagonal of a square; without knowledge of the property formulated above, it would be difficult to get the idea of the proof.

³² The quadratic case is in ibn Thabāt’s *Reckoner’s Wealth* (c. 1200 AD), ed., trans. [Rebstock 1993: 119]; the circular case is widespread.

³³ [Jestin 1937 No. 77].

Akkadian” period^[34] are so much facilitated by familiarity with the geometric-»algebraic« rule $\square(R-r) = \square(R)-2\square(r)+\square(r)$ that this rule is highly likely to have been presupposed; a roughly contemporary tablet exhibits familiarity with the principle that a trapezium is bisected by a parallel transversal whose square is the average between the squares on the parallel sides^[35]. This bisection problem follows the tradition until Abū Bakr and Fibonacci.

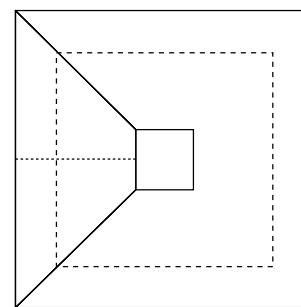

Figure 3. The bisection of a trapezium argued naively from concentric squares.

Other Old Akkadian problem texts ask, for instance, for one side of a rectangle if the area and the other side are known^[36] (a problem which in Medieval sources is included in the group of “rarities” or supra-utilitarian problems, when these are treated as a specific group^[37]). Noteworthy, however, is the complete absence from the Old Akkadian record of problems to be solved by means of a quadratic completion (“mixed second-degree problems”).

When the Old Akkadian state collapsed and was superseded by the “Neosumerian” empire (roughly coinciding with the 21st c. BC), all supra-utilitarian mathematics (and even utilitarian mathematics described in abstraction from the actual use) disappears from the horizon.^[38] After a chaotic period following upon the disintegration of even this empire, the new states that emerged were Akkadian-

³⁴ In the Old Akkadian period (mid-24th to mid-22d c. BC), the Akkadian Sargonide dynasty united the Sumerian city states of southern Iraq into a territorial state. The language of school and administration remained Sumerian, but the impact of Akkadian culture in various domains is subject to no doubt.

³⁵ The rule can be grasped “naively” in a special case by means of the configuration of concentric squares (see Figure 3), and then generalized by proportional distortion.

³⁶ See examples with analysis in [Powell 1976: 424–427].

³⁷ Thus by ibn Thabāt, ed., trans. [Rebstock 1993: 124].

³⁸ Until recently, no Neosumerian mathematical school texts had been identified at all. In her [1995: 205], Eleanor Robson has now shown why: apart from some scratch pads with numbers, they are all “model documents”, fictional accounts and similar calculations laid out in the standard format of real practice and thus routinely mistaken for real paperwork (a first isolated observation pointing in the same direction was made in [Nissen, Damerow & Englund 1990: 139–145]).

This disappearance of mathematics as an autonomous endeavour is striking, since the Neosumerian empire was one of the most meticulously controlled bureaucracies of world history, and developed with impressive efficiency the mathematical tools needed for this purpose (not least the sexagesimal place value system with appurtenant tables for multiplication and reciprocals, metrological conversion and technical constants).

speaking (except perhaps in some insignificant pockets, Sumerian was now a dead language, known only in increasingly distorted form by scribes); much in the literate culture of the Sumerian states was taken over, but some new genres turn up – or rather *almost new*, since they can be connected one way or the other to the Old Akkadian period.

One of these genres (which shall not occupy us any further, but which is important by showing that Akkadian cultural elements were adopted systematically into the new literate tradition) is the omen literature; the other is the reintroduction of supra-utilitarian mathematics into the scribe school (on a scale never seen before), with “second-degree algebra” as the *pièce de résistance*. The starting point was provided by the “sides-and-area riddles” of the surveyor tradition; below (pp. 24ff) we shall see how the scribe school transformed this material; for the present purpose we shall only notice that the fundamental technique – the quadratic completion – is spoken of in one text as “the Akkadian ⟨method⟩”.^[39]

In the Old Akkadian record, as observed, there is no trace of this method (nor of problems where it might have served), even though other area problems are well presented (problems which in later mensuration texts would go together with “sides-and-area-problems”); around 1800 BC, on the other hand, it was the central element of a borrowing of Akkadian material into the scribe school – a piece which within a few decades would give rise to the development of a genuine mathematical discipline. The obvious conclusion seems to be that the artifice was invented at some moment between 2200 BC and 1800 BC (most likely between 2100 and 1900) in a “lay” (that is, non-school) surveyors’ environment, at first as a trick on the level of the intermediate stop of the camel, but that it was soon (and still in the lay environment) discovered that the device permitted the construction and solution of a whole class of problems on squares and rectangles (most of those listed in the beginning of the present section).

Some of these problems do not require the trick: those on two squares, and the rectangle with given area and diagonal. It is noteworthy, however, that all three as encountered in the school texts go via the average of the two unknowns and the common deviation from this average ($a = (x+y)/2$, $d = (x-y)/2$), and then find x and y as $a \pm d$. The same method is used for the other rectangle problems (in single-square problems the same procedure is used, but in these cases a and d by necessity have a different interpretation, since only one magnitude – either $a+d$ or $a-d$ – is asked for).

³⁹ TMS IX, ed. [Bruins & Rutten 1961: 63f]. The commentary in this text edition to the passage in question is completely mistaken (taking $A+l = 40'$ and $A+l+w = 1$ to be the same rectangle problem); but see [Høyrup 1990a: 326].

That the use of average and deviation is no compulsory choice can be illustrated by the solution to the diagonal-area problem: In the mainstream of the tradition (as reflected in the very early Old Babylonian tablet Db₂-146, in the *Liber mensurationum*, in the *Liber embadorum* and in Fibonacci's *Practica*) this was always reduced to one of the other rectangle problems – see Figure 4: either the case where the area and the difference between the sides is given – $\square(l+w) = \square(d)+2A$ – or the one where the area and the sum is known – $\square(l-w) = \square(d)-2A$. This problem was then solved by the usual method involving quadratic completion and average and deviation, even though it seems much easier, at least to us, to find both the sum and the difference between the sides, and to go on from there.^[40]

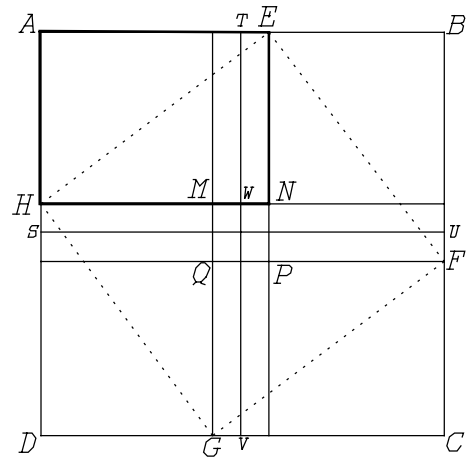

Figure 4. The diagram showing that $\square(d)\pm 2A = \square(\pm w)$ in a rectangle.

The two-square problems $Q_1+Q_2 = \alpha$, $s_1\pm s_2 = \beta$ are also solved in a way that suggests use of the diagram in Figure 4, including average and deviation, that is, the division of the diagram by means of the lines *SU* and *TV*.^[41] Here no reduction to a different problem takes place, and the predilection for average and deviation is therefore by necessity an independent choice.

Implicitly, the configuration contains the most familiar naive proof for the

⁴⁰ The number of arithmetical operations is the same in both computations, and with a single exception even the operations themselves are the same – the alternative method has a halving instead of a squaring, which is the only real simplification. Mathematical simplicity is more a question of habit than we may tend to believe.

⁴¹ This is at least the method used in the Old Babylonian text BM 13901, and (without geometry) in Diophantos's *Arithmetica* I.28. The treatment of the corresponding problem in *Elements* II.9–10 (to whose relevance we shall return) makes use of considerations that are incongruous with anything we know from the second millennium, and is therefore almost certainly a late development (but possibly invented in the practitioners' environment, as suggested by the use of the characteristic configuration from *Elements* II.10 for a wholly different purpose in *Geometrica* AC, ed. [Heiberg 1912: 331]). It is true that the proof of *Elements* II.9 can be drawn into Figure 4, whereas that of II.10 can be imposed on a similar diagram where the smaller square is drawn in the corner of the larger one; but this is not likely to be much more than what follows from the underlying common mathematical structure.

Diophantos's routine use of average and deviation in the second-degree problems is in significant contrast both to what he does in I.1–13 (simple first-degree problems) and I.15–25 (undressed recreational first-degree problems – “give and take”, “purchase of a horse”, etc.). In the former group, one of the numbers is routinely identified with the *arithmós*; in the latter, a particular choice adapted to the case is made.

Pythagorean theorem, and once this theorem is known it is close at hand to use it in the formulation of the solution; but it is not needed. No trace of third-millennium knowledge of the theorem is known, whereas it was familiar in the Old Babylonian school; it hence seems an attractive working hypothesis (and can be nothing more for the time being) that the discovery was made on this configuration, in connection with the problems which it served to solve, and roughly in the same period as the quadratic completion was invented.

Less hypothetical is a discovery made somewhere between the end of the Old Babylonian period (1600 BC) and the Greek adoption of the material, probably only around the mid-first millennium BC. No Old Babylonian school text determines the area of a triangle from a computed height, even though a few late Old Babylonian tablets from Susa contain numerical parameters for regular polygons that presuppose the determination of a height in an isosceles triangle.^[42] *Elements* II.12 and 13 (the “extended Pythagorean theorem”) allow the determination of external and internal heights in scalene triangles from the sides, and it has been a natural assumption that this was a Greek discovery; in Hero’s *Metrica* I.5–6, the Euclidean theorems are indeed used for this purpose; so they are in *Geometrica*, mss. A+C, 12.1–29. A large number of medieval treatises, however, give a different (though of course algebraically equivalent) formula for the inner height,^[43] at times mentioning the Euclidean formula as a possible alternative; for outer heights, however, the Euclidean model is invariably the only possibility. The sole coherent explanation is that the practitioners’ environment had discovered how to determine the height already before the Greek theoretical geometers took over, but only in the case of “genuine”, that is, inner heights;^[44] the Greek theoreticians generalized the concept, and devised a formula that allowed the

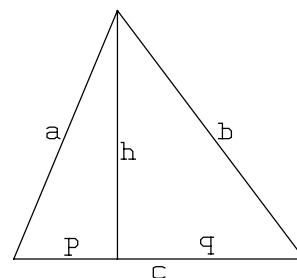

Figure 5. The quasi-algebraic determination of the height in a scalene triangle.

⁴² TMS II and III, [ed. Bruins & Rutten 1961: 23–27].

⁴³ The underlying reasoning (occasionally made more or less explicit) goes as follows (see Figure 5): The difference $\square(q) - \square(p)$ between the projections of the sides equals the known difference $\square(b) - \square(a)$ between the sides themselves, since $\square(a) = \square(p) + \square(h)$, $\square(b) = \square(q) + \square(h)$; but $\square(q) - \square(p)$ can also be understood as the quadratic border between two concentric squares, and thus be determined as the “average length” $2 \cdot (p+q) = 2c$ times the width $^{q-p}/_2$ of the border; together with $^{q+p}/_2 = c/2$ as average, this deviation yields p and q . Afterwards, h is determined from a and p by means of the Pythagorean theorem.

⁴⁴ As al-Khwārizmī explains in the geometrical chapter of his *Algebra* [ed., trans. Gandz 1932: 81], obtuse-angled triangles possess only a single height.

determination of external heights (*viz Elements* II.12). This was adopted by the practitioners; for the inner heights, however, they stuck to the traditional formula.^[45]

Adoptions I: The scribe school

As briefly hinted at above, the early Old Babylonian scribe school borrowed the traditional stock of surveyors' riddles and made it the starting point for the construction of a genuine discipline.

One may legitimately ask how it is possible to distinguish a presumed original stock from a further development in the school, given that the texts left by the school constitute our only source for both. The key is the totally different character of the bundle of problems that turn up in all the later sources and the Old Babylonian corpus as a whole. For the present purpose, the characteristics of this corpus is adequately represented by the totality of the theme text BM 13901 (see p. 10): it begins by two simple cases – square area plus and minus the side. Then it goes on with systematic variation of coefficients, both for the side and for the area; next follow various problems on two, later three or four squares.

In contrast, the problems that recur in classical and medieval (and even later Babylonian) sources are all restricted to “natural” coefficients. A square possesses one area, and either four sides or *the* (characteristic) side; a rectangle possesses a single area, a single diagonal (or possibly two, but that is never used), four sides or two characteristic sides (which determine a single sum or a single difference).

The systematic variation (tedious for those who have already understood no less than for those who never understand) is characteristic of the school situation, and only possible here (cf. p. 7); the reference to the naturally occurring, on the other hand, is characteristic of the riddle. This harmony between, on one hand, the distribution of problems in the sources, on the other, institutionally determined distinctive modes of thought, is what allows us to discriminate an original stock of riddle-type problems from the transformation of the material effected by the school.

Our original starting point – “the four fronts and the area”, No. 23 of our theme text – highlights the difference by pointing to another subtle difference between the riddle and the school problem. A riddle-problem will start by mentioning what is obviously or most actively *there*, and next introduce dependent entities – in the riddle of the three brothers (protectors and potential rapists) and their sisters (virtual victims) the brothers come first, in the case of somebody encountering a group of

⁴⁵ The topic is discussed in detail and with added shades in [Høystrup 1997a: 81–85].

people these first, next their double, etc.^[46] In systematic school teaching, the order will tend to be determined by internal criteria, for instance derived from the method to be applied. The typical school problems will therefore mention the area before the side – in the solution, the area is drawn first, only afterwards will a rectangle $\square(1,s)$ be joined to the area in order to represent the numerical value of the side. The surveyors' riddle, on the other hand, will start with what is immediately given to surveying experience, that is, by the side; the area is found by calculation and hence derivative, and therefore mentioned last.

The ordering of the members is thus one way in which “the four sides and the area” refers to roots outside the school environment. Other ways are the terminology, as already pointed out on p. 10, and the identification of the unit. Finally, the value of the solution is remarkable: With one partial exception (on which presently), no other extant Old Babylonian problem on a single square chooses the side to be 10 (in any order of sexagesimal magnitude) – the standard is 30 (mostly $30'$, i.e., $\frac{1}{2}$), at times 20 (actually $20' = \frac{1}{3}$) is used instead. $10' (= \frac{1}{6})$ is no obvious choice at all – but read as an originally integer 10 moved into the habitual order of magnitude of the school it makes sense if coming from an environment where 10 (and not, for instance, 60) is a round number. Even the value of the solution thus points away from the school and toward lay Akkadian speakers (in Akkadian, as in all Semitic languages, numerals are decadic).

The occurrence of “the four sides and the area” within BM 13901 thus illustrates the role and place of “recreational” problems within a school-based teaching system: After the relative monotony of systematic variation and gradual increase of the intricacy of problems comes an unexpected variation, simple in its mathematical contents but solved by means of an unexpected trick, similar to the usual method (which corresponds to Figure 2) but none the less strikingly different, and obviously school-external in its formulation. The problem, once a challenge and test of competence and professional identity, has really become a piece of mathematical recreation.

The surveyors' riddles was only one of several sources for the Old Babylonian mathematical curriculum (though certainly the most important source for its supra-utilitarian level – well beyond half of all problems are mixed second-degree problems), which mixes several strains of recreational problems^[47] with problems

⁴⁶ Both examples are picked from the *Propositiones ad acuendos iuvenes* (No. 17 and 2, respectively), ed. [Folkerts 1978: 54, 45].

⁴⁷ An interesting specimen clearly unrelated to any surveyors' concern is found in the tablet IM 53957 (ed. [Baqir 1951: 37], but see the revised text in [von Soden 1952: 52]) – one of the very earliest extant Old Babylonian texts, dated c. 1790 BC, slightly older than the diagonal-area

and methods clearly derived from Neosumerian mathematical practice^[48] and with others which seem to derive from an older stratum of Sumerian mathematics.^[49] This situation obviously does not facilitate the attempt to disentangle the original lay tradition from the contributions of the school (I have a hunch that the older Sumerian way to refer to the square root by means of a verbal construction suggests interaction with lay surveying). However, this is not a topic that can be pursued in the present context.

Nor shall we try to trace the adoption process in geographical detail; it will suffice that the adoption occurred more or less independently at least in two different places, Ešnunna in the northern periphery of the Neosumerian empire, and somewhere in the Sumerian heartland (possibly Larsa); and that school texts from some other place toward the north (perhaps Sippar – personal communication from Jöran Friberg) and from Susa suggest continuous interaction with the lay tradition.^[50]

One text from the group that may come from Sippar should be mentioned: BM 80209 – discussed in [Friberg 1981]. It is a catalogue of problem statements on squares and circles. Squares are introduced with a phrase meaning “s, each, confronts itself” (s being a number designating the side), that is, with the very phrase used in the last line of BM 13901 No. 23, merely with an added “each” (which recurs, for instance, in *Liber mensurationum* when one and not all four sides are spoken of). Already this phrase (found in one more text from the “Sippar” group; in the text referred to in note 51; and nowhere else) is sufficient to show the close affinity

problem discussed above. It deals with the filling of a metrological standard unit by means of a container of unknown capacity. It is one of the relatively few Old Babylonian problems solved by a deceptive trick, and thus clearly related to an oral, non-scholastic environment. In many details it is so closely related to problem 37 of the Rhind Mathematical Papyrus that common inspiration is not subject to doubt. This is, as far as I know, the only known trace of cultural links between Middle Kingdom Egypt and contemporary Mesopotamia (and a shared particular use of “ascending continued fractions” shows that the origin of the problem is in a Semitic-speaking environment, that is, Syria or Mesopotamia – cf. below, p. 52); see the discussion in [Høyrup 1998: 124].

⁴⁸ Not least problems making use of technical coefficients that had gone out of practical use in Old Babylonian times – see [Robson 1995: 170, 232].

⁴⁹ The distinction between two strata of Sumerian mathematics was first suggested by Robson [1995: 204–209]; the idea is vindicated by a conspicuous contrast between two different ways to refer to a “square root”, that is, the “squaring” side of an area (through a verbal construction, or as a noun) – see [Høyrup 1998: 65f].

⁵⁰ The arguments for the whole geographical analysis builds on close analysis of terminological differences and orthography; see [Høyrup 1998].

between the lay tradition and the text in question.

One of the square problems of the text is the above-mentioned partial exception to the rule that no Old Babylonian single-square problem except BM 13901 No. 23 chooses the side to be 10. In the present case, however, the square in question is not real and not alone but the mid-square of a quadratic border contained between two concentric squares.^[51]

The circle problems have no direct counterpart elsewhere in the Old Babylonian corpus, but may be regarded as analogues of familiar square problems. If A designates the area, d the diameter and p the perimeter, then a first sequence contains problems $A \pm \alpha p = \beta$, where α is varied systematically; then comes an analogue of BM 13901 No. 9, viz the two-circle problem $A_1 + A_2 = \alpha$, $p_1 = p_2 + 10'$ (with three different values for α). Finally come three problems $A + d + p = \alpha$. Everywhere we must presume p to be the basic parameter, and A and D to be determined as $A = 5' \cdot \square(p)$, $d = 20' \cdot p$ (" $\pi = 3$ ").

The types $A \pm \alpha p = \beta$ and $A_1 + A_2 = \alpha$, $p_1 = p_2 + \beta$ are not found in later sources, and it seems a natural assumption that they are school generalizations (not least the first type, with its systematic variation of α). The type $A + d + p = \alpha$, on the other hand, is also found in two of the *Geometrica* treatises (mss A+C and chapter 24); in ibn Thabāt's handbook;^[52] and with Mahāvīra.^[53] The Greek and Arabic treatises presuppose π to be $3\frac{1}{7}$, whereas Mahāvīra takes it to be 3 in the present problem (occasionally he uses $\sqrt{10}$ as the "precise" value). The Greek and Arabic order is $d + p + A$, Mahāvīra's is $p + d + A$.

Mahāvīra thus has the members in "riddle order" (which, as we notice, is not the case in the Babylonian text). It thus seems probable that his ultimate source is not the school version but the lay riddle tradition, from which even the Old Babylonian school will have taken the problem.

This has an interesting consequence. When expressed in terms of p , the equation $A + d + p = \alpha$ becomes $5' \cdot \square(p) + 1 \cdot 20' \cdot p = \alpha$. In contrast to all the riddle problems listed above (p. 28), this equation is non-normalized. The trick used routinely in the school

⁵¹ This interpretation follows from another text (UET 5,864) discussed in [Kilmer 1964], which asks for the construction of a quadratic border around the corresponding mid-square $\square(s)$ and with the same area, and finds the width of the border through multiplication of s by the reciprocal "of 4, of the four fronts" ("front" however with the Sumerogram, as almost the whole text).

The text is from the South (Ur), but certain features of its highly untypical terminology are shared with "Sippar", Ešnunna and other peripheral texts.

⁵² Ed., trans. [Rebstock 1993: 113f].

⁵³ Ed., trans. [Raṅgācārya 1912: 192].

texts to solve such problems is to transform it into a problem $\square(5'p)+1^{\circ}20' \cdot (5'p) = 5' \cdot \alpha$ (geometrically, by changing the scale in one direction). If the present problem actually belonged to the stock of surveyors' riddles, as seems most likely, then this trick is no invention of the school but another borrowing – but a borrowing which, like the quadratic completion, was transformed in the process of borrowing, from trick into fundamental mathematical technique).

The Old Babylonian social system was brought to a violent end by a Hittite raid in 1600 BC. This was also the end of the old school institution – from now on scribes were trained as apprentices in scribal “families”, about whose actual constitution we know little. The advanced parts of the algebraic discipline seem to have been wiped out in the process. When “algebraic” problems turn up in the texts again in the later first millennium BC, problems with “non-natural” coefficients are totally absent, and discontinuities in the technical use of Sumerograms point to a re-Sumerianization of mathematics, and thus to transmission through communities with no knowledge of Sumerian (that is, non-scribal though not necessarily fully illiterate communities).

The Seleucid text AO 6484^[54] shows that not all second-degree algebra had been forgotten in environments that made use of sexagesimal computation and of the appurtenant tables of reciprocals: it contains several problems where the sum of a number and its reciprocal are given. Since the product is automatically known to be 1, this is a translation into numbers of the rectangular problem where the area and the sum of length and width are given. The same unmistakable problem type is well represented in the Old Babylonian corpus.

We possess no information about the social organization of practical mathematics in the area in the millennium following upon the collapse of the Old Babylonian social system; in any case, however, use of the sexagesimal place value system appears to presuppose a minimal level of cuneiform literacy. The transmission pattern of mathematics from early second to late first millennium Mesopotamia has probably been complex, involving some kind of scribal and as well as definitely non-scribal milieus.

Interaction with environments that were literate in Aramaic (which was written alphabetically and hence allowed “lay”, restricted literacy) is also likely to have existed,^[55] as are farther-ranging links. Whereas the extant Late Babylonian but

⁵⁴ Ed. [Neugebauer 1935: I, 96–99]; the scribe of the tablet introduces himself as an astrologer-priest.

⁵⁵ See [Friberg, Hunger & al-Rawi 1990: 510, 546]. Continuation of the lay surveyors' tradition in a marginally literate community is the most likely explanation of the striking presence in the *Liber mensurationum* of whole phrases and of complex grammatical structures that have

still pre-Seleucid texts (fifth to fourth c. BC?) still move within the range of themes that are known from the Old Babylonian period (even though they are likely to have adopted material from local lay practitioners of some kind), Seleucid texts (third or second c. BC) go far beyond these confines, at times using procedures that in later times are only found outside the Mesopotamian region.

Some novelties are contained in the above-mentioned text AO 6484, together with the evidence for continuity presented by the “number and reciprocal” problems. Most important, however, is the text BM 34568 [ed. Neugebauer 1935: III, 14–17]. One problem treats of alligation, all the others deal with rectangular sides, diagonals and areas,^[56] apart from determinations of d from l and w or of w from d and l , everything is new in some way. Two problems are traditional as such, giving A and either $l+w$ or $l-w$; but the procedures differ from traditional ways, finding for instance in the former case $l-w$ as $\sqrt{(l+w)^2-4A}$, and next $w = \frac{(l+w)-(l-w)}{2}$, $l = (l+w)-w$; no

single problem in the text makes use of average and deviation.

The remaining problems belong to totally new types, among which the following are the most important:

- (1) $l+w+d = \alpha$, $A = \beta$; solved from $(l+w+d)^2-2A = 2d \cdot (l+w+d)$
- (2) $d-l = \alpha$, $w = \beta$ (the reed problem)
- (3) $d+l = \alpha$, $w = \beta$
- (4) $d+l = \alpha$, $d+w = \beta$
- (5) $l+w = \alpha$, $d = \beta$ ^[57]

All turn up again (at times in slightly altered form) in the *Liber mensurationum*, and again in Fibonacci’s *Practica*. The latter sometimes presents the geometrical argument behind the solutions (diagrams which generalize the principle of Figure 4, for instance the square on $l+w+d$, in which the partial squares of course fulfil $l^2+w^2 = d^2$). Given the character of Fibonacci’s treatise and his faithful rendering of proofs we know he has seen it is likely that these proofs go back to the invention of the problems.

a clear Old Babylonian ring (and are totally absent from the Late Babylonian texts!) – cf. [Høyrup 1986: 459f], whereas the problems are of the riddle type (including the order of members) and thus point to a carrying tradition with oral cultural characteristics.

⁵⁶ One of them is dressed as a problem on a reed leaned toward a wall (a situation which is also known from an Old Babylonian text, but used there to for a quite elementary purpose). In the context of rectangular problems it is obvious, however, that the underlying problem is $d-l = 3$, $w = 9$ (symbols as on p. 18).

⁵⁷ This is the problem to which “given diagonal and area” is reduced in the *Liber mensurationum*; but in contrast to this work, the Seleucid solution does not go via average and deviation, and thus remains untraditional.

Types (1)–(4) cannot make use of average and difference, and it is thus no wonder that even the *Liber mensurationum* (otherwise quite faithful to this old procedure) follows the same principle. Type (5), on the contrary, is reduced (twice) in Abū Bakr’s manual to the type $l+w = \alpha$, $A = \beta$, and then solved as in the Old Babylonian texts. If the new problems had been invented within an orbit that was wholly accustomed to the average-deviation technique, it seems more plausible, either that it would have shaped even type (5) in this traditional pattern, or that further transmission within the Mesopotamian region (where Abū Bakr is likely to have composed his treatise and to have found his sources) would have retained the new form. The argument is not conclusive, but all in all BM 34568 seems to have adopted its problems not only from a non-school (that is fairly certain) but even from a non-local tradition. The historical context certainly does not exclude such a process: for half a millennium, Assyrian, Persian and Macedonian armies with train, accountants and surveyors had moved back and forth between the shores of the Indus and those of the Nile; merchants were certainly no less mobile.

Given the similarities of problem types and techniques, the environment where the new problems emerged is likely to build on that surveyors’ tradition which we have discussed so far. Even this is of course historically quite possible – all references to (supposedly identifiable and clear-cut) “traditions” are shorthands for situations that will have been much more turbid than the term tends to make us believe. This is illustrated by the way the diagonal-area rectangle problem is dealt with in various locations. In sources that keep close to the Near-Eastern beginnings (as shown, e.g., by the use of the traditional linguistic format in the *Liber mensurationum*), it was always solved in the traditional way (cf. p. 21). In the Demotic Papyrus Cairo J.E. 89127–30, 89137–43 [ed., trans. Parker 1972: 41–43] from the third c. BC, the problem is solved by what was presented above (p. 21) as the seemingly “much easier way”, without recourse to average and deviation.^[58] The same procedure is followed in the Latin *Liber podismi*.^[59]

⁵⁸ The same papyrus contains material with indubitable Babylonian affinities: the “reed against a wall” is found both in the elementary Old Babylonian variant (to determine w from d and l) and in the sophisticated variant of BM 34568 (together, no less than 8 out of 40 problems).

The (heavily damaged) Demotic Papyrus Carlsberg 30 [ed. Parker 1972: 74] contains a diagram showing the 10×10 square with diagonal $14\frac{1}{7}$, and another with side $14\frac{1}{7}$ and indicated area 200. As we remember from p. 13, Savasorda’s version of the quadratic “surface added to its four sides” presupposes $s = 7$; a problem in AO 6484 [ed. Neugebauer 1935: I, 97] asks for the square side when the diagonal is 10. Even here the Demotic material is thus witness of an interest in “cascades of squares” which also turns up both in Seleucid material and in relation to the index fossil which constituted our starting point.

⁵⁹ Ed. [Bubnov 1899: 511f].

The complexity of the situation is demonstrated by Mahāvīra: the *Ganita-sāra-sangraha* [ed., trans. Raṅgācārya 1912: 224] finds both $l+w$ and $l-w$, as does the Demotic procedure; but then it goes on with average and deviation.

Adoptions II: Greek theory

In [1936] Neugebauer launched the theory that the area geometry of *Elements* II (routinely characterized as “geometric algebra” since Zeuthen [1886: 5ff] formalized a much older notion) would be a translation of the results of a supposedly numerical Babylonian algebra into the idiom of geometry, called forth by the discovery of irrationality; in [1963: 530] he further argued that the Babylonian heritage had become “common mathematical knowledge all over the ancient Near East”, and that a (historically rather implausible) direct translation of cuneiform tablets hence needed not be involved. Neugebauer’s thesis was generally endorsed and only subjected to criticism by Arpád Szabó [1969: 455ff] and Sabetai Unguru [1975; cf. Unguru & Rowe 1981], both of whom emphasized the wholly different thought styles and cognitive aims of the Babylonian and the Euclidean texts. Szabó proposed as an alternative a development from “naive” considerations similar to those described in the passage of Plato’s *Meno* (82B–85E) where a slave boy is led to find out how to double a square.

The discovery that Babylonian “algebra” is not numerical but indeed a “naive” cut-and-paste technique dealing with measurable segments and areas evidently changes the situation, and makes it seem much more plausible that the Greek geometers borrowed and transformed a Babylonian discipline. It has to be asked, however, exactly what kind of mathematics was “common [...] knowledge all over the ancient Near East”, and exactly which knowledge is reflected in the Greek texts.

For this purpose a look at the contents of *Elements* II.1–10 will be useful. In symbolic notation the propositions can be summed up as follows:

1. $\square(e, p+q+\dots+t) = \square(e, p) + \square(e, q) + \dots + \square(e, t)$
2. $\square(e) = \square(e, p) + \square(e, e-p)$
3. $\square(e, e+p) = \square(e) + \square(e, p)$
4. $\square(e+f) = \square(e) + \square(f) + 2\square(e, f)$
5. $\square(a+d, a-d) + \square(d) = \square(a)$
6. $\square(e, e+2d) + \square(d) = \square(e+d)$
7. $\square(e+p) + \square(e) = 2\square(e+p, e) + \square(p)$
8. $4\square(a, d) + \square(a-d) = \square(a+d)$
9. $\square(a+d) + \square(a-d) = 2[\square(a) + \square(d)]$
10. $\square(e) + \square(e+2d) = 2[\square(d) + \square(e+d)]$

At closer inspection, all of this turns out to be familiar from the above – all propositions are indeed justifications (“critiques”) of the ways the surveyor tradition handled its problems. In detail:

Prop. 1 shows that rectangles can be cut (or, the other way round, pasted if possessing a common side); prop. 2 and 3, actually nothing but corollaries of prop. 1, show that sides (transformed into rectangles by being provided with a projecting width 1, cf. note 15) may be removed from or joined to a square.

Prop. 7 is nothing but the rule $\square(R-r) = \square(R)-2r(R,r)+\square(r)$ which appears to be presupposed in the Old Akkadian area text referred to on p. 19 ($R = e+p$, $r = e$), and prop. 4 is its additive counterpart (which is not likely not to have been discovered together with the other).

Prop. 5 and 6 were always used in later times when the algebraic solution to mixed second-degree equations were argued geometrically (only a few Renaissance writers would use II.4); if a is the average between e and $e+2d$, they are easily seen to be algebraically equivalent. Geometrically, however, they correspond to different situations: In prop. 5, the lines $a+d$ and $a-d$ are imagined as parts of a total $2a$, in prop. 6 the line e is part of the line $e+2d$.⁶⁰ The proofs are made correspondingly, and agree with the Old Babylonian respective ways of resolving the two rectangle problems $A = \alpha$, $l+w = \beta$ and $A = \alpha$, $l-w = \beta$. The former also conforms to the solution of problems of the type $\alpha s-Q = \beta$, the latter to those of problems $Q \pm \alpha s = \beta$.

Prop. 8 corresponds to the rule that the border between concentric squares $\square(a+d)$ and $\square(a-d)$ is equal to four rectangles with length equal to the average side a and width equal to the width d of the border, that is, to a rectangle whose length is the average length of the border and whose width is the distance between the squares; this serves, as we have seen, for two-square problems $Q_1-Q_2 = \alpha$, $s_1 \pm s_2 = \beta$. Prop. 9 and 10 correspond to the two-square problems $Q_1+Q_2 = \alpha$, $s_1 \pm s_2 = \beta$.

Prop. 4–7 serve later in the *Elements* (in particular in Book X), but the others are never referred to again: their substance seems so familiar that it need not be mentioned explicitly once its reliability has been validated – cf. [Mueller 1981: 301]. Clearly, *Elements* II.1–10 establish nothing new, they are meant to consolidate the well-known⁶¹ – to be a “critique of mensurational reason”, showing why and

⁶⁰ This observation epitomizes Unguru’s objections to the traditional translation thesis: if seen as numbers, 2 is neither *part* nor *not part* of 6, and there would hence be no reason to translate the same algebraic identity in two different ways; the existence of two algebraically identical propositions only makes sense because geometry and not algebraic identity is at stake.

⁶¹ Prop. 12 and 13 (the extended Pythagorean theorem) do the same for the computation of the projection of one side on another in a scalene triangle – cf. p. 23. The situation of prop. 11 (the area formulation of the division in extreme and mean ratio) is probably different: it is a problem, no theorem, and serves the construction of the regular pentagon in IV.10–11. It has probably been inserted after II.10 because it deals with the same kind of area geometry as the rest of the book (and makes use of II.6). In any case its position indicates that prop. 12–13 form a group on their own, distinct from 1–10.

under which conditions (e.g., genuine right angles) the traditional ways could be accepted, and formulating the outcome in a general form.

How this critique is made can be exemplified on the proof of prop. 6 [trans. Heath 1926: I, 385],

If a straight line be bisected and a straight line be added to it in a straight line, the rectangle contained by the whole with the added straight line and the added straight line together with the square on the half is equal to the square on the straight line made up of the half and the added straight line

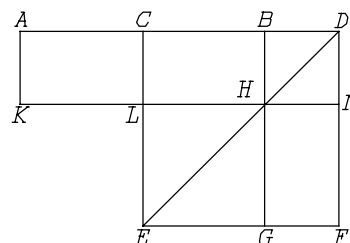

Figure 6. The diagram of *Elements* II.6.

The first half of the demonstration constructs the square on CD, where C is the mid-point of AB; draws the diagonal DE; draws BG parallel to DF and intersecting the diagonal in H; etc. Then Euclid is able to *prove* (in agreement with the “critical” standards of theory) in the second half of the demonstration the equality of the rectangles AL and HF, and to go on precisely as the *Geometrica* area-and-perimeter problem in Figure 2 – which on its part is nothing but the traditional cut-and-paste solution known from the Old Babylonian texts.^[62] Euclid shows that what was traditionally “seen” to be correct can in fact be proved according to the best standards of theoretical geometry. But the *proof idea* remains the same. This holds for the first seven propositions. That of prop. 8 is likely to have been modified so as to facilitate agreement with the general formulation of the theorem, since it locates the smaller square in the corner of the larger one and not concentrically; those of prop. 9–10 were discussed in note 41.

It is noteworthy that the proofs of the single propositions are independent, though some of them could easily be proved from others. That each proposition gets its own proof shows that not only the knowledge contained in the theorems but also the traditional heuristic proofs were meant (if not by Euclid then by a source which he follows faithfully) to be consolidated by theoretical critique.

We notice that all propositions where the distinction can be made (5, 6, 8, 9, 10) are based on average and deviation, not on sum and difference.

Euclid is certainly not responsible for the adoption. What little we know about

⁶² Except for one detail: Euclid’s orientation of the diagram (which is similar in all manuscript traditions and therefore likely to be original). The only Old Babylonian text which suggests an orientation for an area-and-sides configuration (TMS IX, see [Høystrup 1990a: 325]) puts a side to be added *under* the rectangle, as does *Geometrica* 24.3. Informal experiments conducted with historically innocent students reveal a tendency to order area and adjoined sides in the direction of writing (as does TMS IX). If this holds true even for Euclid or his source, the diagram constitutes a piece of weak evidence in support of an adoption from an Aramaic environment.

the work of Hippocrates of Chios and Theodoros of Cyrene shows them to have used some kind of metric geometry. The step from *use* to *critique* could but need not be slightly later: coins from Aegina, which in the fifth century had carried a “naive” geometric diagram, exhibit the diagram of II.4 (including the diagonal that makes the proof “critical”) from 404 B.C. onward [Artmann 1988: 11], which could mean that the topic was hot at that date. All in all it seems plausible that the theory presented in *Elements* II was created in the mid- to late fifth century B.C.

One of the interesting features that connect the Hippocratic fragment on the lunules and Plato’s oblique account of Theodoros’s work on irrationals with each other and with “algebra” and later metric geometry is the use of the term *dýnamis*.

In Diophantos’s *Arithmetic*, to which we shall return, we are told that “it has been approved” to designate the second power of the unknown number as *dýnamis*, thus making it an “element of arithmetical theory”, i.e., of *algebra* as treated by Diophantos [ed. Tannery 1893: I, 4, trans. JH]. This, and various other agreements, shows us that diverse passages in the *Republic* and other Platonic works refer to a second- and third-degree calculators’ algebra, and that even this early algebra used the term *dýnamis* for the second power – cf. [Høystrup 1990c: 368f].

But as it is evident from other passages in Plato and Aristotle; from the Hippocratic fragment; and from the *Elements* and certain Archimedean writings, the term was *also* part of the geometers’ idiom. In this function, its interpretation has provoked much discussion – at times it seems to mean a square, at times it seems to stand for the side of a square or a square root.

Closer analysis of all occurrences shows that the term is no more ambiguous than mathematical terms in general, only unfamiliar [Høystrup 1990c]. It stands for the quadratic figure parametrized by its side, that is, for a square *identified by* – and hence potentially *with* – its side. In other words, a *dýnamis* is a square that *is* its side and *possesses* an area, whereas our square (and the Greek *tetrágōnon*) *has* as side of, e.g., 2 m, and *is* 4 m².

The *dýnamis* did not correspond to the Greek conceptualization of a *figure* as “that which is contained by any boundary or boundaries” (*Elements*, def. 14, trans. [Heath 1926: I, 153]), and already in Euclid’s and Archimedes’s times the term tended to vanish from geometry. This incongruity is striking, given the central importance of the term in the corpus of early references to geometry. It is therefore interesting that a concept with exactly the same unfamiliar structure is present in Old Babylonian mathematics: the *mithartum*, literally a “[situation characterized by the] confrontation of equals”, the square conceived primarily as the square frame.

Szabó [1969: 46f], points out that both *dýnamis* and the verb *dýnasthai*⁶³ have

⁶³ To “master” or to “be worth”, used in geometry to tell that a line “masters” that square

connotations of equivalence and commercial value, together with the basic denotation of physical strength; exactly the same range of de- and connotations belongs with the verb *maḥārum*, from which *mithartum* is derived.

All this does not prove that the Greek *dýnamis* is a calque of the Babylonian *mithartum* (or, rather, an Aramaic term with a corresponding meaning and semantic range and used by Near Eastern mathematical practitioners around 500 BC). But taken together it must at least be counted as circumstantial evidence pointing in that direction. It certainly fits other types of evidence for a fifth-century adoption of that quasi-algebraic technique in which the Babylonian word had served.

In the interest of (relative) brevity I shall abstain from closer discussion of two other Euclidean works which exhibit influence from the surveyors' tradition and riddles: the *Data*, and the treatise *On the Division of Figures*.^[64] Instead we shall look at Diophantos's *Arithmetica*, book I.

This book contains a variety of "recreational" riddles translated into pure-number problems – No. 24 [ed., trans. Tannery 1893: I, 56–59], for instance, asks for three numbers (say, p , q , and r) that fulfil the condition $p+(q+r)/3 = q+(p+r)/4 = r+(p+q)/5$ – an unmistakable expurgated version of the "purchase of a horse". Translated as follows into symbols, propositions 27–30 look as follows:

- 27. $p+q = \beta$, $p \cdot q = \alpha$
- 28. $p+q = \beta$, $p^2+q^2 = \alpha$
- 29. $p+q = \beta$, $p^2-q^2 = \alpha$
- 30. $p-q = \beta$, $p \cdot q = \alpha$

or, when interpreted as rectangle and two-square problems:

- 27. $l+w = \beta$, $A = \alpha$

of which it is the side; in Aristotle's formulation of the Pythagorean theorem (*De incessu animalium* 708^b33-709^a2), the hypotenuse "is worth" the sides containing the right angle)

⁶⁴ *Data*, prop. 84 and 85 show that if the area of a rectangle and either the difference between the sides or their sum are given in magnitude, then the sides are also given in magnitude. Whereas *Elements* II.5 and 6 are critiques of the procedures by which the two most prominent rectangle problems were solved, *Data* 84–85 may thus be considered as *solvability theory* for the same problem types. The treatise *On the Division of Figures* contains the bisection of the trapezium by a parallel transversal as one of its problems. But both works go far beyond anything that can be imagined to have belonged to any group of lay practitioners, and take whatever was borrowed from them as the inspiration and starting point for far-ranging independent developments.

A similar though more modest generalization starting from but leaving behind the adopted material is found in *Elements* VI.28–29, the application of an area with defect or excess, where the defect or excess is not required to be square (as in II.5–6) but similar to a given parallelogram.

28. $s_1+s_2 = \beta$, $Q_1+Q_2 = \alpha$
 29. $s_1+s_2 = \beta$, $Q_1-Q_2 = \alpha$
 30. $l-w = \beta$, $A = \alpha$

Diophantos's immediate aim coincides with that of the practitioners: to find the solution – neither to construct a critique nor to formulate solvability theory. In contrast to what we find in sources that reflect the culture or teaching of practitioners, however, theoretical reflection is made explicit in two different ways: firstly, each problem is formulated in general terms, even though the solution is demonstrated on a paradigmatic example; secondly, by the formulation of diorisms telling the conditions for solvability when such conditions exist. These conditions are told to be *plasmatikós*, which may (but need not) mean that they can be seen in a diagram, a *plásma* (which indeed they can, namely the traditional “naive” diagrams) – cf. the discussion in [Høyrup 1990a: 349f].

All of this – *Elements* II.1–10 and VI.28–29, *Data* 84–85, the bisected trapezium from the treatise *On the Division of Figures*, *Arithmetica* I.27–30 – refers to the stock of problems that seems to have belonged to the lay surveyors' tradition already before the Old Babylonian scribe school adopted its riddles. With explainable exceptions it also exhausts this stock: rectangle problems $A+(l\pm w) = \alpha$, $l\mp w = \beta$ were always solved by an elegant “change of variable” which allowed reduction to the types $A = \alpha$, $l\pm w = \beta$, and they were thus uninteresting on their own from a theoretical point of view – the only place where they *might* at a pinch have fitted in is in the *Arithmetica*. The circle problem $A+d+p = \alpha$ was of course inaccessible to treatment inasmuch as the ratio between the circular diameter and perimeter was inexpressible. The rectangle with given area and diagonal is not present in itself, but by means of the Pythagorean theorem it is solved via either *Elements* II.4 or II.7 (as explained by Fibonacci and Savasorda). The equality of perimeter and area for squares and rectangles has no place within a geometry not based on a unit length.

In all cases where the alternative presents itself, these texts make use of average and deviation; the new ways of BM 34568 and the Demotic papyri leave no trace in the works of the Greek theoreticians.

Something more than mere traces are found, however, if we go to the rare surviving representatives of the practical tradition of the Greco-Roman world proper. As reported on p. 32, the Latin *Liber podismi* (whose title shows it to be derived from a Greek model) finds the sides of a rectangle (actually a right triangle) from diagonal and area in the same way as in the Demotic Cairo Papyrus, that is, from sum and difference. The Greco-Egyptian Papyrus Genève 259,^[65] contains three problems

⁶⁵ Ed., trans. [Rudhardt 1978], further discussion in [Sesiano 1986]; probably 2nd c. CE. A

on right triangles:

1. $w = 3$, $d = 5$
2. $w+d = 8$, $l = 4$
3. $l+w = 17$, $d = 13$

The first, of course, tells us nothing. The second and third, on their part, belong to types that only turn up in the Seleucid and Demotic material. No. 3, moreover, is one of the types which, when adopted into the tradition reported by Abū bakr, was solved by means of average and deviation. The Geneva Papyrus does nothing similar; even though its exact method for nos 2 and 3 are idiosyncratic, their general tenor is that of the Seleucid text.

Other reflections of the surveyors' tradition in Greek practitioners' mathematics (and sources acquainted with this kind of mathematics) were mentioned above: The presence of the square problem $Q_{+4}s$ and the circle problem $A+d+p = \alpha$ in the *Geometrica* compilations, the references to the equality of area and perimeter of squares and rectangles in the *Theologumena arithmeticae*. They constitute important supplementary evidence for the link between the Greek world and the Near Eastern tradition, and confirm the observation that no trace of the specific inventions of the Old Babylonian scribe school can be found. But they are neutral with respect to the distinction between links to the core tradition and the "Seleucid-Demotic" innovations.

Adoptions III: The proofs and associates of al-jabr

In the early ninth century, al-Khwārizmī wrote his treatise on the topic *al-jabr wa'l-muqābalaḥ* on the exhortation of the caliph al-Ma'mūn. It contains a chapter on practical geometry and one on inheritance computations, but none of them concern us here.^[66]

forthcoming paper from Sesiano's hand shows (while changing the numerical parameters involved) that his reconstruction of the method of the heavily damaged No. 3, wholly hypothetical in the first publication, is next to inescapable.

⁶⁶ The chapter on inheritance computation is indeed algebraic in the current sense, but all is of the first degree and based on the *šay'*, "thing" (*res* in the Latin translations, *cosa* in the Italian tradition). This kind of computation is called *regula recta* by Fibonacci (*Liber abaci*, ed. [Boncompagni 1857: 191 and *passim*] and introduced long before his presentation of *al-jabr wa'l-muqābalaḥ*, namely when he solves the dressed version of Diophantos' *Arithmetica* I.15 exactly as Diophantos solves it by means of an unknown *arithmós*, "number". Unless we are deceived by a highly improbable coincidence, Arabic *šay'* and Greek *arithmós*-algebra (which is no exclusive property of Diophantos, see [Robbins 1929] and [Vogel 1930]) belong to the same kin, and only coalesced with *al-jabr* at a late moment.

The geometrical chapter is important evidence for the Near Eastern tradition of practical

As I have argued elsewhere [Høystrup 1991], the best extant witness of al-Khwārizmī's original text is Gerard of Cremona's twelfth-century Latin translation [ed. Hughes 1986]; the best translation of the published Arabic text (whose branch of the stemma has undergone at least at least three successive revisions after its separation from the version used by Gerard) is [Rozenfeld 1983]. Since Rosen's English translation [1831] remains more widely diffused than both of these, I shall point out when appropriate its insufficiencies with respect to the present discussion.

The *al-jabr* technique, we are told, is based on three kinds of numbers: [square] roots, possessions,^[67] and simple numbers. Fundamentally, it thus deals with [unknown] amounts of money, square roots of these amounts, and numbers; al-Khwārizmī explains, however, that the possession is produced as the product of the root with itself, in agreement with the identification of the “root” with the “thing” and of the “possession” with the product of the “thing” with itself when the technique is applied (see presently).

The three kinds of numbers are combined in 6 equation types:

Possession is made equal to roots^[68]

Possession is made equal to number

Roots are made equal to number

Possession and roots are made equal to number^[69]

Possession and number is made equal to roots

Roots and number are made equal to possession

For each of these, a numerical example is given, and a rule for solving it (followed by non-normalized examples, whose normalization is explained). In the fourth case, for instance, the example is “A possession and 10 roots are made equal to 39 dirhams”, and the rule that

geometry, cf. [Høystrup 1997a]; note 44 cited its statement that obtuse-angled triangles possess only a single height. But it has nothing to do with the adoption of the area riddles into *al-jabr*.

⁶⁷ “Squares” in Rosen's translation; but the Arabic word is *māl*, meaning a [monetary] property, adequately translated by Gerard as *census*. In Rosen's defense it should be said that he takes care to translate the Arabic term for a square (*murabba*^c) as “quadrate” – a point too fine to be observed by most users of the text.

Rozenfeld uses *kvadrat* for both *māl* and *murabba*^c.

⁶⁸ The revised Arabic text, followed by Rosen and Rozenfeld, speaks of “possessions”, in agreement with the habit of later Arabic algebra; since all the basic examples are normalized, we may be confident that Gerard's singular form corresponds to the original text.

The rules as quoted by Thābit (see note 70) also refer to a single possession.

⁶⁹ For obscure reasons, Rosen changes the order into “Roots and squares are equal to number”, against his own Arabic text.

you halve the roots, which in this question are 5. You then multiply them with themselves, from which arises 25; add them to 39, and they will be 64. You should take the root of this, which is 8. Next remove from it the half of the roots, which is 5. Then 3 remains, which is the root of the possession. And the possession is 9.

Thus, if the equation is $y+a\sqrt{y} = b$, then $\sqrt{y} = \sqrt{b+(\frac{a}{2})^2} - \frac{a}{2}$ and $y=(\sqrt{y})^2$.

Working in the ambience of the House of Wisdom, al-Khwārizmī was not satisfied with a list of unexplained rules (though this may have been all the caliph had asked for), and he therefore added a set of geometrical proofs.^[70] Later on he makes it clear that the geometrical proofs he constructs in order to illustrate the calculation with binomials (and which he tries, though without being satisfied with the outcome, to construct for trinomias) are of his own making; he says nothing similar about the present proofs, and already for this reason we may therefore assume that he borrowed them from somewhere.

“Somewhere” turns out to be familiar. The case whose rule was quoted above gets two proofs. The diagram of the first is shown in Figure 7. At first is drawn the square AB with unknown side, which represents the possession, and each of whose sides is thus equal to the root. The 10 roots are distributed equally, as the four rectangles G , H , T and K , each of which has the width $2\frac{1}{2}$. In each corner a square $2\frac{1}{2} \times 2$ is missing; adding these we get for the larger square a total area $39+4 \cdot 6\frac{1}{4} = 39+25 = 64$; etc. All in all we get

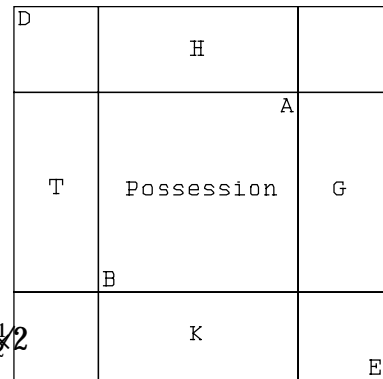

Figure 7. Al-Khwārizmī’s first proof of the case “Possession and roots made equal to number”.

a proof of the rule $y = \sqrt{b+4 \cdot (\frac{a}{4})^2} - 2 \cdot \frac{a}{4}$, – not of the

one that was to be proved.

Afterwards comes a second proof, the diagram of which is shown in Figure 8 (analogous to the procedure shown in Figure 2 and to Figure 6). This time the proof fits the procedure to be proved perfectly. Both for grammatical reasons and because the proof style is more concise and formal (also compared with the proofs of the

⁷⁰ That only the rules and not the proofs belonged with the extant *al-jabr* technique (that which al-Ma^cmūn had asked al-Khwārizmī to expound in handy form) follows from Thābit ibn Qurrah’s slightly later Euclidean justification of the rules of *al-jabr* [ed., trans. Luckey 1941].

As we shall see (p. 46), later representatives of the “low” variety of *al-jabr* are also devoid of proofs.

following cases), there are reasons to believe that this second proof was added by al-Khwārizmī in a later revision of the text. Even if this is not the so it comes after the first, and since it is obviously more adequate, al-Khwārizmī must have had some particular, conscious or sub-conscious reason to put it in this position – and to include the first proof at all. This reason can be one of two: it may have been the one which came first to al-Khwārizmī’s mind, and which he found simpler; or it may be the one with which he expected the reader to be more familiar (or both). Since the first proof is evidently derived from the solution of the problem of “four sides and quadratic area” with which we are familiar from BM 13901 (without the quadripartition, which is likely to be a scribe school innovation), al-Khwārizmī’s source for the proof in question (and then by association also the others, which are all of the habitual types) is clearly our familiar surveyors’ tradition and its riddle collection. These must hence have been around.

The origin of the *al-jabr* technique is not known. Al-Ma^cmūn’s request suggests that it was not stock knowledge in Iraq in the early ninth century. It has been suggested at times that it came from Central Asia, since not only al-Khwārizmī but also ibn Turk, another early writer on the topic, had their family roots there. A Medieval story reported by David King [1988] tells that the technique was adopted from the Iranian Fars province already under the caliph ^cUmar (634–644), transmitted orally for a while and then lost, and only restored by al-Khwārizmī. Though hardly reliable in its details, the story supports a descent from a location somewhere to the east or north-east of Iraq. Below, p. 57, supplementary arguments will be presented that point in the same direction.

Nor is it known whether *al-jabr* is somehow a descendant of earlier “algebras” – Babylonian, Greek “geometric” or Diophantine, Indian, or the surveyors’ riddles. Once the geometric proofs and the *šay*²-technique have been seen to be secondary grafts, both Greek possible sources become unlikely; since *al-jabr* is a numerical technique and not geometrical, having the possession and not the root as its basic unknown, any assumption of a link to the naive-geometrical techniques requires stronger arguments than the similarity between the *al-jabr* “halving of the roots” and Abū Bakr’s and Savasorda’s “halving of the sides” (which might after all be borrowed from *al-jabr*, or be the expression nearest at hand in the absence of a formal term for the coefficient). As to a possible descent from Indian algebra as known, e.g., from Brahmagupta, Léon Rodet already argued in [1878] that the sophisticated algebraic schemes of the Indians and their free use of negative entities make al-

G	A Posses- sion B
Five	FIVE D

Figure 8. Al-Khwārizmī’s second proof of the case “Possession and roots made equal to number”.

Khawārizmī's work look much too primitive for this hypothesis to seem plausible. Even this, however, is a question to which we shall return.

Thābit does not mention al-Khawārizmī's proofs when presenting his own, based on *Elements* II.5–6 (cf. note 70). Further on in the “High” tradition of Islamic algebra – from Abū Kāmil onward – al-Khawārizmī was the recognized founder of the discipline as it had come to look, and the geometric proofs were accepted as an integrated part of the subject (though from Thābit and Abū Kāmil onward mostly formulated with reference to *Elements* II.5–6).^[71] They were evidently taken over in the Latin translations of al-Khawārizmī and Abu Kāmil, and also in Fibonacci's *Liber abaci* and *Pratica geometrie*. With Fibonacci, however, the development is taken one step further: when paraphrasing Gerard's translation of al-Khawārizmī in the *Pratica* [ed. Boncompagni 1862: 56] he corrects the statement that numbers are “roots, possessions, and simple numbers”. Now they are *aut radices quadratorum, aut quadrati, aut numeri simplices*, “either roots of squares, squares, or simple numbers” – and the squares are real geometrical squares, whereas the roots are strips as long as the side of the square, and with width 1. The formulations in *Liber abaci* are similar [ed. Boncompagni 1857: 406]. Here, the *census* only appears when the first problem type is introduced (p. 407): “The first mode is, when the square, which is called *census*, is made equal to roots”.

Liber abaci gives two versions of the geometric proof of the first mixed case ; one is similar to al-Khawārizmī's second proof (see Figure 8), the other to Thābit's and Abū Kāmil's (that is, a reference to *Elements* II.6). In the *Pratica*, the paradigmatic example for the same case, here defined as “number is made equal to quadrate and roots”, is nothing but the problem “a [quadratic] area and its four sides make 140” (solved however with a reference to *Elements* II.6). Regarding geometric proofs as the gist of the discipline, Fibonacci in fact reconstructs it, deriving it in part indirectly, in part directly from the old sides-and-area riddles (which he knew from Gerard's translation of Abū Bakr, from Savasorda, and from unidentified sources^[72]).

Not all Islamic *al-jabr* after al-Khawārizmī and Thābit belong to the “high” division, even though the “low” register has attracted the attention of modern scholars and medieval translators into Latin much less. The “low” register seems to be characterized by an ordering of cases that differs from al-Khawārizmī's; by

⁷¹ [Dold-Samplonius 1987] is a convenient survey.

⁷² One trace of the latter is Leonardo's replacement of a corrupt problem from the *Liber mensurationum* with a problem which is certainly not of his own making – cf. [Høyrup 1996a: 56]. Among other things, the problem in question has the sides before the area, whereas Fibonacci's own preference (strong enough to make him correct Abū Bakr) is to have the area first.

defining the cases in non-normalized form, as in the revised al-Khwārizmī text; *and by having no geometric proofs*. This is exemplified in al-Karajī’s *Kāfī* [ed., trans. Hochheim 1878];^[73] ibn al-Bannā’s *Talkhīṣ* [ed., trans. Souissi 1969: 92]; and ibn al-Yāsamin’s *Urjuza fi’l-jabr wa’l-muqābalah* (paraphrase in symbols in [Souissi 1983: 220–223]).

Common prejudice notwithstanding, this type – and not Fibonacci’s *Liber abaci* – was the kind of algebra that inspired the beginnings of Italian vernacular algebra in the earliest fourteenth century. This can be seen from the earliest specimens: the Vatican manuscript of Jacopo da Firenze’s *Tractatus algorismi* (dated 1307);^[74] Paolo Gherardi’s *Libro di ragioni* from 1328 [ed. Arrighi 1987]; and a composite *abbaco* book from Lucca from c. 1330 [ed. Arrighi 1973]. But even vernacular European algebra succumbed to the spell of geometrical reasoning, and *not* in the first instance because of the influence of Fibonacci or al-Khwārizmī. Like the former in the *Pratica*, but in wholly independent and fully “naive” and non-Euclidean terms, Piero della Francesca uses the problem of “a square whose surface, joined to its four sides, makes 140” as the paradigmatic example explaining the rule for the case “*censo* and things are equal to number” (and like Fibonacci he takes *censo* to be another term for the square figure) – see Figure 9: *TE* is told to be the square or *censo*, *AI* to be 4, and *G* the mid-point of *AI*; *GF* is then

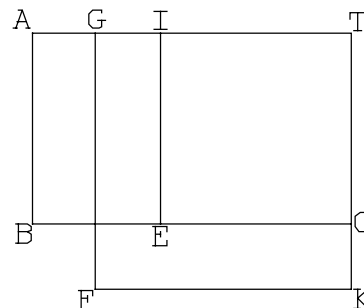

Figure 9. Piero’s diagram for his “surface joined to its four sides”.

⁷³ It may astonish to see al-Karajī listed in the “low” category, but the surprise may serve to show that the categorization has nothing to do with mathematical competence and incompetence; as shown by Saliba [1969], al-Karajī’s terminology in the *Kāfī* demonstrates its algebra to be derived from a pre-al-Khwārizmīan model; similarly, much in its geometry turns out to be close to the traditional practitioners’ model – cf. [Høytrup 1997a].

The *Fakhrī*, it should be pointed out, is wholly different; it shows al-Karajī to be wholly conversant with the geometric proofs and ready to present them when he thinks they fit the context.

⁷⁴ Described in [Karpinski 1929] on the basis of the manuscript Vat. Lat. 4826. Two other copies of the manuscript exist: Ricc. 2236 (Florence) and Trivulziana 90 (Milan). An edition of the former was made by Annalisa Simi [1995]; the latter is described in [van Egmond 1980: 166f]. The chapter on algebra, however, is only present in the Vatican manuscript; my observations are derived from the edition which I am preparing for the moment [Høytrup 1998a].

Jacopo’s algebra is distinguished from the Latin tradition by complete absence of geometric proofs. Moreover, not a single example or problem is shared with *Liber abaci* or with the Latin translations of al-Khwārizmī and Abū Kāmil, and no example is given in the abstract form involving *censo*, *cosa* and number.

drawn so as to exceed *BE* with as much as *IG*; etc.^[75]

As a rule, Piero's algebra problems are derived from the preceding vernacular tradition, not from the *Liber abaci*, as his geometrical riddles are generally derived from some unidentified (but certainly indirect) link to the Islamic world; but his use of geometry shows that times were ripe for Pacioli's reintroduction of Fibonacci's version in *Summa de arithmetica*. In part in fairly original "naive" shape, in part in versions more or less touched by the Euclidean "critical" form, the riddle tradition had reconquered all levels of European algebra, as Cardano was to encounter it.^[76]

So far this chapter has concentrated on the development of *al-jabr* and its continuation in the Christian world. Time and again, however, the argument has presupposed the survival of the geometrical riddle tradition well beyond its adoption into al-Khwārizmī's *Algebra*. Abū Bakr is likely to be a contemporary of al-Khwārizmī – perhaps slightly earlier – (cf. note 18), but his manual was still at hand in Toledo when Gerard went there in the mid-twelfth century. Savasorda writes some three centuries after al-Khwārizmī, and clearly does not depend on Abū Bakr. Ibn Thabāt is another century younger, and totally independent of both Abū Bakr and Savasorda.

Even the Christian world turns out to have been in repeated contact with the geometrical tradition. Fibonacci, as mentioned, draws on another representative of the tradition when replacing a corrupt passage in the Gerard-translation of Abū Bakr; Piero seems to have access to yet another representative – and even Pacioli, and probably his vernacular source, seems to possess some kind of information about the tradition which allows him to correct in part another corrupt passage in Leonardo

⁷⁵ Much later in the treatise comes a whole collection of problems derived from the riddle tradition: $Q = 2 \cdot {}_4s$; $Q = {}_4s+60$; $d-s = 6$; $A = \alpha$, $l = w+2$; etc., in versions which (when numerical parameters were not fixed by tradition) are shared neither with Abū Bakr nor (with a single exception) with Fibonacci. Piero has obviously borrowed the area-with-sides problem from this group and put it in the place where he needed it for pedagogical reasons. The two other mixed cases [ed. Arrighi 1970: 133, 136] are illustrated by the problems ${}_4s-Q = 3$ and $Q-{}_4s = 77$, similarly borrowed from the geometric collection.

⁷⁶ The introductory passage [trans. Witmer 1968: 7f] of his *Ars magna* runs as follows:
This art originated with Mahomet the son of Moses the Arab. Leonardo of Pisa is a trustworthy source for this statement. There remain, moreover, four propositions of his with their demonstrations, which we will ascribe to him in their proper places. After a long time, three derivative propositions were added to these. They are of uncertain authorship, though they were placed with the principal ones by Luca Paccioli. [...].
Cardano obviously knows some of the particular types of the *abbaco* tradition – but the names of the discipline are the geometrizers: al-Khwārizmī, Fibonacci, and Pacioli. Quite appropriate as a background for his own decomposition of the cube.

without understanding it so well that he is able to correct it fully.^[77]

But the geometrical tradition has left yet another possible trace which was not mentioned so far, namely – curious as it seems at first – in a particular type of number problems that went together with the *al-jabr* tradition.

It seems never to have attracted much attention that by far the larger part of the problems to which al-Khwārizmī applies the *al-jabr* technique proper are of the type “I have divided 10 into two parts [which fulfil some arithmetical relation]”, and that similar but mostly different problems also constitute a dominant group in the *Liber abaci* (31 problems in total, to which comes a division of 10 into three and two divisions of 12 into two parts). From one point of view, the type reminds of the staple recreational problems; the “purchase of a horse” is also present in the *Liber abaci* in an impressive number of different versions. From another point of view, however, the two situations are fundamentally different. The horse problems differ by the number of potential buyers that are involved, and by the fractions which they ask from each other; but in as far as mathematical structure is at stake, the only important difference is that some versions are indeterminate and others determinate. The “divided 10”, however, is as varied in structure as can be within the framework of second-degree algebra (with some *abbaco* writers, it also serves the formulations of higher-degree problems) – so much so indeed that one is almost tempted to speak of a particular discipline. For structural reasons, its origins must be presumed to be independent of *al-jabr* – even though it may be the availability of the *al-jabr* technique that has allowed it to unfold as creatively as attested in the *Liber abaci*, whereas, *vice versa*, the existence of this problem type may be what allowed the possession-root riddles – the *al-jabr* archetype – to unfold as a genuine algebra (this would explain that the problem type is so prominent in al-Khwārizmī, Fibonacci and others).

Arguments from the choice of a particular numerical parameter for a particular use – in particular if this parameter seems as “natural” a choice as 10 – are wholly gratuitous unless it can be shown, firstly, that this choice is not constrained;^[78] secondly, that the same choice is not made with comparable frequency in other unconstrained cases (that is, not made just because the number itself is “remarkable” independently of its use or function^[79]).

In the Old Babylonian case, it was possible to argue in this way for the

⁷⁷ Cf. [Høyrup 1996a: 60] and note 24 with preceding text.

⁷⁸ The choices of 6 and 8 as sides of a rectangle and of 13, 14 and 15 as the sides of a scalene triangle are constrained in the sense that they constitute, respectively, the second-simplest and the simplest example with integer hypotenuse and height.

⁷⁹ I refer to the category of “remarkable numbers” introduced in [Høyrup 1993].

significance of the value 10 for the square side; further on in the surveyors' tradition, 10 turns out to be the privileged value of the side of regular polygons, but to be rare in other functions – see [Høyrup 1997a: 90f]. On the other hand, it is less than certain that the summation of series with precisely 10 members in Demotic and Seleucid sources is significant, since the same number occurs repeatedly in other functions in the texts where the series are found.

Returning to the divided 10, one may observe that quite a few of the problems in question also make use of other unconstrained parameters; none of these are ever 10.^[80] The *Liber abaci* also contains a problem where the excess of one number over the other is given – but this excess is 6. There is thus no doubt that the choice of 10 is significant; the question is, *what* it signifies beyond the delimitation of the group.

The majority of the problems in both al-Khwārizmī and (in particular) the *Liber abaci* do not look meaningful in a geometrical perspective; but some of them have the same structure as familiar geometrical riddles – if a and b designate the parts into which 10 is split, the following:

$$a^2 + b^2 = 58 \text{ (al-Khwārizmī)}$$

$$ab = 21 \text{ (al-Khwārizmī)}$$

$$a^2 - b^2 = 40 \text{ (al-Khwārizmī)}$$

$$a^2 + b^2 = 62\frac{1}{2} \text{ (Liber abaci)}$$

Moreover, Fibonacci's splitting of 10 into $a+b+c$ requires that $a \cdot c = b^2$ (thus that a , b and c be in continued proportion) and that $a^2 + b^2 = c^2$ (thus that the squares be in extreme and mean ratio). The same problem, only with c given instead of $a+b+c$ and formulated about the sides and the diagonal of a rectangle, is No. 51 in the *Liber mensurationum*.^[81] Finally, al-Khwārizmī has the problem $a^2 + b^2 + (a-b) = 54$, which can be reduced to the type $c^2 + d^2 = \alpha$, $c+d = \beta$ by the same trick as the reduction of the old rectangle problem $A+(l-w) = \alpha$, $l+w = \beta$ to the type $A = \alpha$, $l+w = \beta$.

If we go to a less sophisticated treatise – namely Jacopo da Firenze's *Tractatus algorismi* – we shall find three representatives of the group: $\frac{a}{b} = 100$ (fol. 36^v); $a \cdot b = 20$ (fol. 398^v); and $a \cdot b + (a-b) = 22$ (fol. 40^v); the latter two of course correspond to the riddles $A = \alpha$, $l+w = \beta$ and $A+(l-w) = \alpha$, $l+w = \beta$. A fourth problem about two abstract numbers a and b (other problems of his concern composite interest, partnership', etc.) demands that they be in the proportion 4:9, and that $a \cdot b = a+b$

⁸⁰ 10 does occur in the *Liber abaci*, but in a constrained situation which makes critical use of the fact that $\frac{10}{a} + \frac{10}{b} = \frac{10}{a} \cdot \frac{10}{b}$ precisely if $a+b = 10$.

⁸¹ In principle, Fibonacci might have borrowed the problem from Abū Bakr and translated it into the familiar structure of the split number 10; but this would not agree with his normally faithful use of sources.

(fol. 37^v), and is thus a determinate version of the type $A = l+w$. Three of four problems are thus not only geometrically meaningful but even members of the earliest group of riddles.^[82]

The less sophisticated the source – this is the obvious conclusion – the more manifest the similarity with the geometrical riddles. A second, almost as obvious conclusion is that these riddles constitute the starting point even for the arithmetico-algebraic quasi-discipline of “splitting the 10”. Since the problems are also well represented in Jacopo’s treatise, clearly related to the “low” type and not otherwise influenced by al-Khwārizmī,^[83] there is no reason to believe the latter to be responsible for integrating even this problem type into *al-jabr*, as he integrated the technique of naive geometry; indeed, his explanation of the three types of numbers (where the possession is told to be produced as the product of the root with itself, see p. 41) refers to what he “found”, that is, found in common use among the practitioners of the art.

When al-Khwārizmī solves these problems, his initial name for the unknown is the *šay*², the “thing”; its square is then identified with the *māl*, after which “thing” and “root” are used indiscriminately. This suggests that the adoption of the divided 10 into *al-jabr* may be part of the general process in which the *regula recta* or *arithmós/šay*²-algebra was integrated. If *regula recta*, *arithmós*- and *šay*²-techniques are really historically linked, as suggested in note 66, it seems near at hand to connect even the numbers divided into two in Diophantos’s *Arithmetica* I to the “divided ten”, although his numbers are different.

Adoptions IV: India

Indian algebra is not *prima facie* a likely consanguine of any of the “Western algebras” so far discussed. However certain the connections when we discuss planetary theory and the mathematics of astronomy and the sharing of a number of “recreational problems”, the algebraic schemes of Brahmagupta or the Bakhshālī manuscript^[84] are so different from anything Babylonian, Greek or Arabic that

⁸² The fourth problem, too, possesses a geometrically meaningful interpretation: to find a

Rodet's rejection [1878] of an Indian inspiration for al-Khwārizmī would seem to hold no less certainly the other way.

The source which makes this certainty less than certain is Mahāvīra's *Ganita-sāra-sangraha* – as it may be guessed from the repeated references to this work in the preceding pages: to the problems of square and rectangular area equal to the perimeter and to rectangle problems of the type $A = \alpha$, $2l+2w = \beta$; to the determination of the area enclosed between four mutually touching circles; to the circle problem $p+d+A = \alpha$ (with the ratio $p:d$ assumed to be 3); to the determination of the sides of a rectangle from A and d , finding both $l+w$ and $l-w$ but then continuing with average and deviation.

But there is more to it. Mahāvīra not only uses average and deviation, he has a technical term for the method, called *saṅkramaṇa* [ed. Raṅgācārya 1912: 93], ascribed to the experts (“those who have gone to the end of the ocean of calculation”); he bisects a trapezium; he makes use of and has a particular name (*bhāgānubandha* fractions, pp. 63f) for the “ascending continued fractions” (expressions of the form $\frac{a}{p} + \frac{b}{q} \cdot \frac{1}{p} + \frac{c}{r} \cdot \frac{1}{q} \cdot \frac{1}{p} + \dots$) which are found in Semitic-speaking mathematical cultures but never spread much in those which adopt it.^[85] He also has the same formula for the determination of the height of a scalene triangle as the practical treatises of the Islamic Middle ages, and explains the way it is derived (p. 197) – but only for inner heights (cf. note 44). The area of a circular border is determined as the average perimeter times the breadth (not very significant, but alternative orderings of the sequence of operations are possible).

There are also puzzling links to the indeterminate rectangle problems of *Geometrica*, chapter 24, which were not considered above, and which I shall therefore not discuss further.^[86] Nor shall I pursue other features of Mahāvīra's geometry which confirm the existence of connections to the Near Eastern tradition. What was already listed should suffice.

What needs to be asked for is the date of these connections, and the direction of borrowing.

Date first. The question is whether Mahāvīra borrowed from the Islamic world of his own – and al-Khwārizmī's – century, or repeats traditional teachings of the Jaina school going back to its bloom in the later first millennium BC (or at the latest to the early first millennium CE).

⁸⁵ See [Høyrup 1990d], and above, note 47.

⁸⁶ Strictly speaking, the *Geometrica* problems deal with right triangles, and only Mahāvīra's with rectangles. In general, Greek geometry – even when practical – often translated traditional rectangle problems into problems dealing with right triangles (thus also *Liber podismi* and the Geneva papyrus).

For many reasons, a borrowing in Mahāvīra’s own times seems excluded. The technical names for the method of average and deviation shows that these had been fully naturalized and assimilated into the Jaina tradition, in a way which this conservative tradition would certainly not have permitted to happen within a century or two (Mahāvīra and other Jainas still stuck to $\pi = \sqrt{10}$ as the “precise” alternative to 3, centuries after the adoption of more precise approximations in non-Jaina astronomy, cf. [Sen 1971: 161]); an ascription of the explanation of the determination of the height in a scalene triangle to “learned teachers” also suggest the explanation to be part of the established tradition.

The circle problem $p+d+A = \alpha$, if borrowed from the medieval Near East, would have gone together with $\pi = 3\frac{1}{7}$; Mahāvīra might certainly have corrected it, and assumed the handy value 3 ($\sqrt{10}$ would be too inconvenient as a coefficient). But he would certainly not have had any reason to order the members in a way that points back to an epoch where the perimeter and not the diameter was the primary circular parameter (Mahāvīra himself determines the area as $A = 3 \cdot (\frac{d}{2})^2$, not as $\frac{\pi d^2}{4}$).

As a group, finally, Mahāvīra’s borrowings from the surveyor’s tradition reminds much more of the limited stock that is attested in the various classical sources (from *Geometrica* to *Theologumena arithmeticae*) than of, e.g., the *Liber mensurationum*.

As to the direction of borrowing, most of the material we are speaking of was present in the Near East well before the arrival of the Aryans into India. Mahāvīra’s preference for average and deviation (and his hybrid solution to the rectangle problem $A = \alpha$, $d = \beta$) shows that even the innovations which we find in Seleucid and Demotic mathematics cannot come from his school. The only inventions which may as well have been made in India as anywhere else in the region where our tradition was diffused are the determination of the height in a scalene triangle; and the indeterminate rectangle problems.^[87]

⁸⁷ My intuition (for what it is worth!) finds the idea behind the height determination so congenial to the old tradition that an import seems implausible; the indeterminate problems, on the other hand, are unlike the main body of what we know from the Near East and the Mediterranean region (only the rules for creating Pythagorean triples and certain techniques of Diophantos are comparable), whereas indeterminate analysis is known to be an Indian favourite.

Maybe one should add “Hero’s formula” to the list of possible Indian contributions. Although al-Bīrūnī is often taken to be a reliable witness when ascribing it to Archimedes, Hero’s omission of such an ascription (in spite of his correct ascription of everything which we *know* belongs to Archimedes) is strong counter-evidence. But if we dismiss Archimedes as the inventor, a familiar argument in favour of Archimedes may be turned around: *who else* among Greek theoretical geometers? As a rule, the formula only appears in manuals derived from the practitioners’ tradition together with the Archimedean approximation to π – but its presence with Mahāvīra, in the company of the old value 3 and the Jaina invention

Socially, the Jaina community of the first millennium BC – with its strong representation of artisans, merchants and officials^[88] – is of course the best possible candidate for a channel through which foreign practical mathematics might be adopted.

Familiarity with the naive quasi-algebra of the surveyors' tradition does not necessarily entail that Jaina – nor, *a fortiori*, Indian – algebra in general was strongly influenced by this technique. Such a claim remains a hypothesis; all that can be said is that the hypothesis is no longer implausible, the characteristics of Indian algebra notwithstanding. If we look at other features of Mahāvīra's work, we may notice a strong tendency toward technical formalization (and expansion) – precisely the processes that might lead from algorithms based on a naive area technique to the algebraic schemes of the mid-first millennium. A paradigmatic example is the treatment of *mūla* or “root” problems. These are problems arising as variations of a familiar older type, called *Bhāga* by Mahāvīra – in symbolic notation $x - \frac{1}{p}x - \frac{1}{q}x - \frac{1}{r}x = \alpha$. This structure may be varied in different ways by the inclusion of square roots – and Mahāvīra lists five specific categories, each with its own fixed rule for solution:^[89]

$$\text{Mūla: } x - (bx + c\sqrt{x} + a) = 0$$

$$\text{Śēsamūla: } x - bx + (c\sqrt{x - bx} + a) = 0$$

$$\text{Dviragraśēsamūla: } x - a_1 - b_1(x - a_1) - b_2(x - a_1 - b_1(x - a_1)) - \dots - c\sqrt{(x - a_2)} = 0$$

$$\text{Amśamūla: } x - c\sqrt{bx - a} = 0$$

$$\text{Mūlamiśra: } \sqrt{x} + \sqrt{x \pm d} = m$$

Other variations are obtained by squaring:

$$\text{Bhāgasamvarga: } x - \frac{m}{n}x \cdot \frac{p}{q}x - a = 0$$

$$\text{Amśavarga: } x - \left(\frac{m}{n}x \pm d\right)^2 - a = 0$$

$\sqrt{10}$, indicates that it may after all not be a child of Greek geometrical theory but rather an uncle or cousin. Even in this case, however, and for similar reasons, my intuition objects to locating the innovation in an Indian environment.

⁸⁸ See, e.g., [Thapar 1966: 65].

⁸⁹ I quote Raṅgācārya's translations into symbols [1912: 75–84]. In the text, all problems are evidently concretely dressed, dealing with elephants, peacocks, swans, pearls, etc.

$$\text{Bhinnadrśya: } x - \frac{m}{n}x \cdot \frac{p}{q}x - \frac{r}{s}x = 0$$

An elaborate system of this kind is obviously not the product of an oral or semi-oral practitioners' culture but of a school. It presupposes the fundamental techniques for transforming an equation, together with insights permitting the solution of quadratic equations. The transformations *could* be performed within the kind of algebraic schemes which we know from other sources from the first millennium CE, but the techniques have disappeared from view in the rules given by Mahāvīra; similarly, the kind of insights by which quadratic problems were solved may well have been those coming from the surveyors' riddles, since they were actually present – but we have no means to decide.

To sum up: The Near Eastern geometric and quasi-algebraic tradition, with its riddles and characteristic techniques, did reach India, probably already in Antiquity, and they made enough impression to become part of venerated traditions; but whether they remained isolated, well conserved fossils or entered decisively in the process leading to the formation of Indian algebra – this remains an open question.

Al-jabr revisited

What *can* be said with some certainty about the Indian development is that the complex system of *mūla* problems will have unfolded from a simpler base of problems involving an unknown quantity, its root and a number, in the likeness of the *māl*-root problems of *al-jabr*. Such problems may have circulated as riddles among those practical professional people who were part of the early Jaina community.

Al-jabr, as it was stated, is conceptualized as a numerical technique – the basic unknown quantity is an amount of money, and the simple numbers are also numbers of *dirhams*. On this background, the metaphorical use of a term for the square root which literally means “root [of a tree]” (*jidhr*) is therefore anomalous, and only explainable if it is a calque (and thus evidence of a borrowing from a terminology where the metaphor makes sense).

Now, Sanskrit *mūla* is also a metaphor; in non-technical language it refers to the root of a tree, and to the basis or fundament of something. In mathematics it refers (at least from Āryabhata onward, but probably well before that, if we can ascribe the core of Mahāvīra's mathematics to the early Jainas) to the square root understood as “that side on which a square rests”.^[90]

The two parallels in combination – each one taken alone already quite

⁹⁰ See [Datta & Singh 1962: I, 169f].

characteristic – makes it almost certain that *al-jabr* is somehow linked to India. Rodet’s objections remain valid, which means that it is certainly not derived from the high-level algebra of Āryabhata and Brahmagupta, not even from what we find in the Bakhshālī manuscript. But it may descend from a lay riddle tradition inspiring the beginnings of Jaina *mūla* algebra, or from riddles still circulating in India outside the environments of schools and advanced astronomy in the Middle Ages. Alternatively, both *al-jabr* and the simple beginnings of Indian *mūla* algebra (and the “root” metaphor) may be derived from a geographically intermediate source, centred perhaps in Iran, perhaps in Khwarezm. Since the radical reduction of a rich variation of unknown quantities to one single standardized “possession” is less probable than poetical proliferation starting from simple beginnings, an origin outside the dominion of elephants and peacocks seems somewhat more likely than an original Indian inspiration.

If this is true, the possible influence of the geometrical riddles on the development of Indian algebra tells nothing about the ultimate inspiration of the *al-jabr* riddles. *Al-jabr*, that technique which gave ALGEBRA its name, remains the only kind of second-degree algebra whose connection to the Near Eastern surveyors’ riddles remains a fully unsubstantiated assumption;^[91] all we may say is that *if* it originated together with the root metaphor, it was it first represented geometrically. As we have seen, however, already the transformation of the riddle archetype into a proper algebraic technique may be due to interaction with a descendant of the surveyors’ tradition (the divided 10) – and its transformation from a technique into a reasoned mathematical discipline is almost certainly based on a borrowing of their cut-and-paste technique, first in original “naive” form, next as transformed by Euclid.

Closing

The Romanticist folklorists invented the idea of *Gesunkenes Kulturgut* – if not derived from literate culture, folktales and other popular genres were in their view the remains of shipwrecked mythologies, of disintegrated epics which had once formed the spirit of the “people” in the sense of “nation”. True culture was the creation of bards and prophets; the weary peasant telling jokes in the tavern and the uneducated wet nurse with her fairy tales were nothing but filth from which it was necessary to free the expressions of the genuine people, the “nation in itself”.

The above pages have tried to tell a very different story, about a kind of culture that was “popular” in the sense of standing outside literate high culture and thus

⁹¹ I have not discussed the Chinese material, but the presence of the reed-against-a-wall in “Seleucid” version in the *Nine Chapters on Arithmetic* demonstrates the existence of a connection.

“low” in the moral topography of the *literati*, but was certainly neither national (a-national or cosmopolitan, however, rather than international) nor the undifferentiated possession of everybody not belonging to the learned class.

In an epoch where “identity” – a concept which some thirty years gained wide currency thanks to the feminist movement – is rampantly reduced to “national identity”, I find it worthwhile tracing how the transnational culture of a group of professionals provided nourishment for a variety of exclusive high cultures – one of which, while its science is developing *de facto* into “world science”, takes pride in that development and uses it as an argument in favour of its own perennial superiority.

Such was my motivation for telling the story – but not for finding out, this rather happened through two decades of intellectual Brownian movement guided by curiosity and by esteem for practitioners’ knowledge gained during my teaching experience in an engineering school. But its merits should certainly be evaluated with reference to its verisimilitude and independently of any disgust with our favourite pretext of the moment for sending the others to a better world. In other words: Is the story a mere fable with a moral imposed from without – is it plausible – or is it inevitable?

“Inevitable” is a pompous word, and much of what was proposed was only stated to be plausible. It may be useful to sum up (what I see as) the main relative certainties and the main doubts.

The heart of the whole argument was of course the existence and transmission of the cluster of riddle-like problems inventoried on pp. 16–18, and the mainly lay and oral character of the carrying environment. The existence of the cluster seems subject to no reasonable doubt: so many of the characteristic problems turn up together so often that accidental independent formulation of just these problems in each other’s company is practically excluded – not to mention the conserved word order and solution of “the four sides and the area” over 3300 years.

As to the carrying environment, so much seems quite certain that Babylonian “algebra”, Greek “geometric algebra” and the geometric technique reflected in Abū Bakr’s and al-Khwārizmī’s works are not in direct communication; they are much too different, and know too little about each other’s finer creations for this to be the case. The connections of which the shared relation to the cluster of riddles bears witness must be due to a social environment that was “lay” at least in the sense that it has left no direct traces in the records of scholarly traditions. To speak of this environment as forming “a tradition”, in preposterous singular form, is certainly a dubious simplification, permissible only because we have no knowledge of the precise character of the environment in different areas and epochs (which was certainly not without variation), of the relation between genuine master-apprentice

networks and systems based on elementary schooling, nor of the extent to which basic literacy was involved in conservation and transmission. All that follows from the analysis of mathematical and expository style is that the environment was often much closer to the style of oral culture than the various scholarly cultures which it links – but that it was certainly never exclusively oral since the end of the Old Babylonian period, nor uniformly literate.

That Old Babylonian school algebra starts on a foundation that had been laid outside the school environment seems very certain, and also that it was only the school that transformed a basic riddle technique into a genuine mathematical discipline. Precisely how much was invented before the school took over is less easy to decide, as are third- as well as second-millennium interactions between the school and the lay environment.

The Near Eastern inspiration for the geometry of *Elements* II (if not necessarily for Greek metric geometry in general) seems well established; also well established (though not argued in detail above) is the lack of inspiration from the developed algebraic *discipline* of the Old Babylonian school. As to the contact points, the material suggests (but does not tell with certainty) that the traces of the surveyors’ “tradition” which we find in late Ancient practical mathematics are somehow linked to the shaping it received in the Achaemenid and Hellenistic melting pot (which also seems to have influenced Mahāvīra) – whereas the inspiration of the theoretical geometers (and of that “logistician’s algebra” from which Diophantos took his term *dýnamis*) seems unaffected by this new shape, and may go back to Syrian (Aramaic-speaking) contacts.

The composite nature of *al-jabr* as found in al-Khwārizmī’s treatise seems subject to little doubt; that he was responsible himself for the introduction of naive-geometric proofs is equally well established, and almost as certain is that he borrowed the proofs from the surveyors’ “tradition”, which can be seen also from Abū Bakr’s manual to have been at hand in his world. The distinct origin of *šay²* / “thing”-algebra and its identification with the basic Greek *arithmós*-technique was concluded from combination of various pieces of evidence, none of which is conclusive in itself, but which only fit well together under this condition; the singling-out of the “divided ten” and related problems is similarly built on combined evidence. That both (even if originally distinct) had been adopted into *al-jabr* before al-Khwārizmī encountered it seems to follow directly from his text, but is also suggested by other data. That the assimilation of the number problems in question was the occasion for the transformation of riddles into a general algebraic art is a conjecture which fits the evidence but is no necessary conclusion. Somewhat more but not fully certain is the linking of the *al-jabr* riddles to India, either by descent or common descent.

That Mahāvīra draws on material going back to the surveyors’ tradition is hardly

to be doubted – and that the connection goes back to Antiquity is a reasonable inference. However, whether this material was of general importance for the creation of Indian algebra is an open question.

Only one of the texts used above was unpublished (Jacopo's algebra chapter), and only one was published less than 20 years ago (the Old Babylonian tablet BM 80209). For the rest, the argument was built on attention to details in familiar texts and on analysis of the distribution of characteristic features. There is no reason to believe that the possibilities of this approach are exhausted. Further work along similar lines is likely to make some of the "reasonable conclusions" drawn above more certain – to transform them into open questions – or to invalidate them altogether. The grand canvas offered in these pages is certainly in need of that.

BIBLIOGRAPHY

- Arrighi, Gino (ed.), 1970. Piero della Francesca, *Trattato d'abaco*. Dal codice ashburnhamiano 280 (359*–291*) della Biblioteca Medicea Laurenziana di Firenze. (Testimonianze di storia della scienza, 6). Pisa: Domus Galileana.
- Arrighi, Gino (ed.), 1973. *Libro d'abaco*. Dal Codice 1754 (sec. XIV) della Biblioteca Statale di Lucca. Lucca: Cassa di Risparmio di Lucca.
- Arrighi, Gino (ed.), 1974. Pier Maria Calandri, *Tractato d'abbacho*. Dal codice Acq. e doni 154 (sec. XV) della Biblioteca Medicea Laurenziana di Firenze. Pisa: Domus Galiaeana.
- Arrighi, Gino (ed.), 1987. Paolo Gherardi, *Opera mathematica: Libro di ragioni – Liber habaci*. Codici Magliabechiani Classe XI, nn. 87 e 88 (sec. XIV) della Biblioteca Nazionale di Firenze. Lucca: Pacini-Fazzi.
- Artmann, Benno, 1990. "Mathematical Motifs on Greek Coins". *Mathematical Intelligencer* 12:4, 43–51.
- Baqir, Taha, 1951. "Some More Mathematical Texts from Tell Harmal". *Sumer* 7, 28–45.
- Boncompagni, Baldassare (ed.), 1857. *Scritti di Leonardo Pisano matematico del secolo decimoterzo*. I. Il *Liber abaci* di Leonardo Pisano. Roma: Tipografia delle Scienze Matematiche e Fisiche.
- Boncompagni, Baldassare (ed.), 1862. *Scritti di Leonardo Pisano matematico del secolo decimoterzo*. II. *Practica geometriae et Opusculi*. Roma: Tipografia delle Scienze Matematiche e Fisiche.

- Brentjes, Sonja, & Manfred Müller, 1982. "Eine neue Interpretation der ersten Aufgabe des altbabylonischen mathematischen Textes AO 6770". *NTM. Schriftenreihe für Geschichte der Naturwissenschaften, Technik und Medizin* 19:2, 21–26.
- Bruins, E. M., & M. Rutten, 1961. *Textes mathématiques de Suse*. (Mémoires de la Mission Archéologique en Iran, XXXIV). Paris: Paul Geuthner.
- Bruins, E. M., 1968. "Le premier problème de AO 6770". *Revue d'Assyriologie* 62, 80–82.
- Bubnov, Nicolaus (ed.), 1899. Gerberti postea Silvestri II papae *Opera mathematica* (972—1003) Berlin: Friedländer.
- Busard, H. L. L., 1968. "L'algèbre au moyen âge: Le »Liber mensurationum« d'Abû Bekr". *Journal des Savants*, Avril-Juin 1968, 65–125.
- Cantor, Moritz, 1907. *Vorlesungen über Geschichte der Mathematik*. Erster Band, von den ältesten Zeiten bis zum Jahre 1200 n. Chr. Dritte Auflage. Leipzig: Teubner.
- Curtze, Maximilian (ed.), 1902. *Urkunden zur Geschichte der Mathematik im Mittelalter und der Renaissance*. (Abhandlungen zur Geschichte der mathematischen Wissenschaften, vol. 12–13). Leipzig: Teubner.
- Datta, Bibhutibhusan, & Avadhesh Narayan Singh, 1962. *History of Hindu Mathematics. A Source Book*. Parts I and II. Bombay: Asia Publishing House. ¹Lahore: Motilal Banarsidass, 1935–38.
- Dold-Samplonius, Yvonne, 1987. "Developments in the Solution to the Equation $cx^2+bx=a$ from al-Khwārizmī to Fibonacci", pp. 71–87 in D. A. King & G. Saliba (eds), *From Deferent to Equant: A Volume of Studies in the History of Science in the Ancient and Medieval Near East in Honor of E. S. Kennedy*. (Annals of the New York Academy of Sciences, Volume 500). New York: New York Academy of Sciences.
- Dupuis, J. (ed., trans.), 1892. Théon de Smyrne, philosophe platonicien, *Exposition des connaissances mathématiques utiles pour la lecture de Platon*. Paris: Hachette.
- Folkerts, Menso, 1978. "Die älteste mathematische Aufgabensammlung in lateinischer Sprache: Die Alkuin zugeschriebenen *Propositiones ad acuendos iuvenes*. Überlieferung, Inhalt, Kritische Edition". *Österreichische Akademie der Wissenschaften, Mathematisch-Naturwissenschaftliche Klasse. Denkschriften*, 116. Band, 6. Abhandlung.
- Friberg, Jöran, Hermann Hunger & Farouk al-Rawi, 1990. "»Seeds and Reeds«: A Metro-Mathematical Topic Text from Late Babylonian Uruk". *Baghdader Mitteilungen* 21, 483–557, Tafel 46–48.
- Friberg, Jöran, 1981. "Methods and Traditions of Babylonian Mathematics, II: An Old Babylonian Catalogue Text with Equations for Squares and Circles". *Journal of Cuneiform Studies* 33, 57–64.

- Gandz, Solomon (ed., trans.), 1932. "The Mishnat ha Middot, the First Hebrew Geometry of about 150 C.E., and the Geometry of Muhammad ibn Musa al-Khowarizmi, the First Arabic Geometry <c. 820>, Representing the Arabic Version of the Mishnat ha Middot". *Quellen und Studien zur Geschichte der Mathematik, Astronomie und Physik. Abteilung A: Quellen* 2.
- Gandz, Solomon, 1948. "Studies in Babylonian Mathematics I. Indeterminate Analysis in Babylonian Mathematics". *Osiris* 8, 12–40.
- Gerdes, Paulus, 1996. *Femmes et Géométrie en Afrique Australe*. Paris: L'Harmattan.
- Goody, Jack (ed.), 1968. *Literacy in traditional Societies*. Cambridge: Cambridge University Press.
- Goody, Jack, 1977. *The Domestication of the Savage Mind*. Cambridge: Cambridge University Press.
- Goody, Jack, 1987. *The Interface between the Oral and the Written*. Cambridge: Cambridge University Press.
- Guttman, Miquel, & J. Millas y Vallicrosa (eds, trans.), 1931. Abraam bar Hiia. *Llibre de geometria. Hibbur hameixihà uebatixbòret*. (Biblioteca Hebraico-Catalana, 3). Barcelona: Alpha.
- Heath, Thomas L. (ed., trans.), 1926. *The Thirteen Books of Euclid's Elements*. 2nd revised edition. 3 vols. Cambridge: Cambridge University Press / New York: Macmillan. ¹1908.
- Heiberg, J. L. (ed., trans.), 1880. Archimedis *Opera omnia* cum *Commentariis* Eutocii. 3 vols. Leipzig: Teubner, 1880–1881.
- Heiberg, J. L. (ed., trans.), 1912. Heronis *Definitiones* cum variis collectionibus. Heronis quae feruntur *Geometrica*. (Heronis Alexandrini Opera quae supersunt omnia, IV). Leipzig: Teubner.
- Heiberg, J. L. (ed., trans.), 1914. Heronis quae feruntur *Stereometrica* et *De mensuris*. (Heronis Alexandrini Opera quae supersunt omnia, V). Leipzig: Teubner.
- Hochheim, Adolph (ed., trans.), 1878. *Kâfi fil Hisâb (Genügendes über Arithmetik)* des Abu Bekr Muhammed ben Alhusein Alkarkhi. I-III. Halle: Louis Nebert.
- Høystrup, Jens, 1986. "Al-Khwârizmî, Ibn Turk, and the Liber Mensurationum: on the Origins of Islamic Algebra". *Erdem* 2 (Ankara), 445–484.
- Høystrup, Jens, 1990a. "Algebra and Naive Geometry. An Investigation of Some Basic Aspects of Old Babylonian Mathematical Thought". *Altorientalische Forschungen* 17, 27–69, 262–354.
- Høystrup, Jens, 1990b. "Sub-Scientific Mathematics. Observations on a Pre-Modern Phenomenon". *History of Science* 28, 63–86.
- Høystrup, Jens, 1990c. "Dýnamis, the Babylonians, and Theaetetus 147c7—148d7". *Historia Mathematica* 17, 201–222.

- Høyrup, Jens, 1990d. "On Parts of Parts and Ascending Continued Fractions". *Centaurus* **33**, 293–324.
- Høyrup, Jens, 1991. "»Oxford« and »Cremona«: On the Relations between two Versions of al-Khwārizmī's *Algebra*". *Filosofi og videnskabsteori på Roskilde Universitetscenter*. 3. Række: *Preprints og Reprints* 1991 nr. 1. To appear in *Proceedings of the 3rd Maghrebian Symposium on the History of Mathematics Alger, 1–3 December 1990*.
- Høyrup, Jens, 1993. "'Remarkable Numbers' in Old Babylonian Mathematical Texts: A Note on the Psychology of Numbers". *Journal of Near Eastern Studies* **52**, 281–286.
- Høyrup, Jens, 1995. "«Les quatre côtés et l'aire» – sur une tradition anonyme et oubliée qui a engendré ou influencé trois grandes traditions mathématiques savantes", pp. 507–531 in *Histoire et épistémologie dans l'éducation mathématique*. Actes de la première Université d'été européenne, Montpellier 10 au 13 juillet 1993. Montpellier: IREM de Montpellier. A typographic disaster, republished in corrected form as 1996b.
- Høyrup, Jens, 1996a. "'The Four Sides and the Area'. Oblique Light on the Prehistory of Algebra", pp. 45–65 in Ronald Calinger (ed.), *Vita mathematica. Historical Research and Integration with Teaching*. Washington, DC: Mathematical Association of America. Marred by printing errors, due to the publisher's omission of a proof reading stage.
- Høyrup, Jens, 1996b. "«Les quatre côtés et l'aire» – sur une tradition anonyme et oubliée qui a engendré ou influencé trois grandes traditions mathématiques savantes", pp. 192–224 in E. Gallo, L. Giacardi & C. S. Roero (eds), *Associazione Subalpina Mathesis. Seminario di Storia delle Matematiche "Tullio Viola". Conferenze e Seminari 1995–1996*. Torino: Associazione Subalpina Mathesis.
- Høyrup, Jens, 1997a. "Hero, Ps.-Hero, and Near Eastern Practical Geometry. An Investigation of *Metrica*, *Geometrica*, and other Treatises", pp. 67–93 in Klaus Döring, Bernhard Herzhoff & Georg Wöhrle (eds), *Antike Naturwissenschaft und ihre Rezeption*, Band 7. Trier: Wissenschaftlicher Verlag Trier.
- Høyrup, Jens, 1997b. "Mathematics, Practical and Recreational", pp. 660–663 in Helaine Selin (ed.), *Encyclopaedia of the History of Science, Technology, and Medicine in Non-Western Cultures*. Dordrecht etc.: Kluwers.
- Høyrup, Jens, 1998. "The Finer Structure of the Old Babylonian Mathematical Corpus. Elements of Classification, with some Results". To appear in *Fs Oelsner*, in the series *Alter Orient und Altes Testament*.
- Hughes, Barnabas, O.F.M., 1986. "Gerard of Cremona's Translation of al-Khwārizmī's *Al-Jabr*: A Critical Edition". *Mediaeval Studies* **48**, 211–263.

- Jestin, Raymond, 1937. *Tablettes sumériennes de Šuruppak au Musée de Stamboul*. (Mémoires de l'Institut Français d'Archéologie de Stamboul, III). Paris: Boccard.
- Karpinski, Louis C., 1929. "The Italian Arithmetic and Algebra of Master Jacob of Florence, 1307". *Archeion* **11**, 170–177.
- Kilmer, Anne Draffkorn, 1964. "The Use of Akkadian *DKŠ* in Old Babylonian Geometry Texts", pp. 140–146 in *Studies Presented to A. Leo Oppenheim, June 7, 1964*. Chicago: The Oriental Institute of the University of Chicago.
- King, David, 1988. "A Medieval Arabic Report on Algebra Before al-Khwārizmī". *al-Masāq* **1**, 25–32.
- Koch, Ludovica, 1995. "«Fiamma da fiamma s'infiamma». Sulle domande, sui silenzi e sulla teoria della conoscenza nell'epica germanica". *Studi Germanici*, n.s. **30–31** ("1992–1993"; published 1995), 9–43.
- Lévy, Tony, 1995. "Transmission et traduction, transfert et tradition: réflexions sur la culture mathématique dans le monde juif médiéval". *Césure. Revue de la Convention Psychanalytique* **8**, 135–150.
- Luckey, Paul, 1941. "Tābit b. Qurra über den geometrischen Richtigkeitsnachweis der Auflösung der quadratischen Gleichungen". *Sächsischen Akademie der Wissenschaften zu Leipzig. Mathematisch-physische Klasse. Berichte* **93**, 93–114.
- Mueller, Ian, 1981. *Philosophy of Mathematics and Deductive Structure in Euclid's Elements*. Cambridge, Mass., & London: MIT Press.
- Neugebauer, O., 1935. *Mathematische Keilschrift-Texte*. I-III. (Quellen und Studien zur Geschichte der Mathematik, Astronomie und Physik. Abteilung A: Quellen. 3. Band, erster-dritter Teil). Berlin: Julius Springer, 1935–1937.
- Neugebauer, O., 1936. "Zur geometrischen Algebra (Studien zur Geschichte der antiken Algebra III)". *Quellen und Studien zur Geschichte der Mathematik, Astronomie und Physik*. Abteilung B: *Studien* **3** (1934–36), 245–259.
- Neugebauer, Otto, 1963. "Survival of Babylonian Methods in the Exact Sciences of Antiquity and Middle Ages". *Proceedings of the American Philosophical Society* **107**, 528–535.
- Neugebauer, Otto, 1975. *A History of Ancient Mathematical Astronomy*. 3 vols. Berlin etc.: Springer.
- Nissen, Hans J., Peter Damerow & Robert Englund, 1990. *Frühe Schrift und Techniken der Wirtschaftsverwaltung im alten Vorderen Orient. Informationsspeicherung und -verarbeitung vor 5000 Jahren*. Bad Salzdetfurth: Verlag Franzbecker.
- Ong, Walter J., S.J., 1967. *The Presence of the Word. Some Prolegomena for Cultural and Religious History*. New Haven & London: Yale University Press.
- Ong, Walter J., 1982. *Orality and Literacy. The Technologizing of the Word*. London & New York: Methuen.

- Pacioli, Luca, 1523. *Summa de Arithmetica geometria Proportioni: et proportionalita*. Novamente impressa. Toscolano: Paganinus de Paganino, 1523.
- Parker, Richard A., 1972. *Demotic Mathematical Papyri*. Providence & London: Brown University Press.
- Picutti, Ettore, 1989. "Sui plagi matematici di frate Luca Pacioli". *Le Scienze* **40**:246 (febbraio 1989), 72–79.
- Powell, Marvin A., 1976. "The Antecedents of Old Babylonian Place Notation and the Early History of Babylonian Mathematics". *Historia Mathematica* **3**, 417–439.
- Pucci, Pietro, 1997. *Enigma Segreto Oracolo*. Pisa & Roma: Istituti Editoriali e Poligrafici.
- Raṅgācārya, M. (ed., trans.), 1912. The *Ganita-sāra-sangraha* of Mahāvīrācārya with English Translation and Notes. Madras: Government Press.
- Rebstock, Ulrich, 1993. *Die Reichtümer der Rechner (Ġunyāt al-Hussāb) von Ahmad b. Ṭabāt (gest. 631/1234). Die Araber – Vorläufer der Rechenkunst*. (Beiträge zur Sprach- und Kulturgeschichte des Orients, 32). Walldorf-Hessen: Verlag für Orientkunde Dr. H. Vorndran.
- Robbins, Frank Eggleston, 1929. "P. Mich. 620: A Series of Arithmetical Problems". *Classical Philology* **24**, 321–329.
- Robson, Eleanor, 1995. "Old Babylonian Coefficient Lists and the Wider Context of Mathematics in Ancient Mesopotamia, 2100–1600 BC". *Dissertation*, submitted for D.Phil in Oriental Studies. Wolfson College, Oxford.
- Rodet, Léon, 1878. "L'algèbre d'al-Khārizmi et les méthodes indienne et grecque". *Journal Asiatique*, 7^e série **11**, 5–98.
- Rosen, Frederic (ed., trans.), 1831. The *Algebra* of Muhammad ben Musa, Edited and Translated. London: The Oriental Translation Fund.
- Rozenfeld, Boris A. (trans.), 1983. Muhammad ibn Musa al-Xorezmi, *Kratkaja kniga ob isčiclenii algebrj i almukabaly*, pp. 20–81, 118–142 in S. X. Siraždinov, Muxammad ibn Musa al-Xorezmi *Matematičeskie traktaty*. Taškent: Izdatel'stvo »FAN« Uzbekskoj CCP.
- Rudhardt, Jean, 1978. "Trois problèmes de géométrie, conservés par un papyrus genevois". *Museum Helveticum* **35**, 233–240.
- Saliba, George A., 1972. "The Meaning of al-jabr wa'l-muqābalaḥ". *Centaurus* **17** (1972-73), 189–204.
- Schöne, Hermann (ed., trans.), 1903. Herons von Alexandria *Vermessungslehre und Dioptra*. (Heronis Alexandrini Opera quae supersunt omnia, vol. III). Leipzig: Teubner.
- Sen, S. N., 1971. "Mathematics [in India]", pp. 136–212 in D. M. Bose, S. N. Sen & B. V. Subbarayappa (eds), *A Concise History of Science in India*. New Delhi: Indian National Science Academy.

- Sesiano, Jacques, 1986. "Sur un papyrus mathématique grec conservé à la Bibliothèque de Genève". *Museum Helveticum* **43**, 74–79.
- Simi, Annalisa, 1995. "Trascrizione ed analisi del manoscritto Ricc. 2236 della Biblioteca Riccardiana di Firenze". *Università degli Studi di Siena, Dipartimento di Matematica. Rapporto Matematico* N° 287.
- Souissi, Mohammed, 1983. "Ibn al-Yāsamin, savant mathématicien du Maghrib", pp. 217–225 in *Actas del IV Coloquio Hispano-Tunecino* (Palma, Majorca, 1979). Madrid: Instituto Hispano-Arabe de Cultura..
- Souissi, Mohamed (ed., trans.), 1969. Ibn al-Bannā³, *Talkhīs a^cmāl al-hisāb*. Tunis: L'Université de Tunis.
- Szabó, Arpád, 1969. *Anfänge der griechischen Mathematik*. München & Wien: R. Oldenbourg/Budapest: Akadémiai Kiadó.
- Tannery, Paul (ed., trans.), 1893. Diophanti Alexandrini *Opera omnia* cum graecis commentariis. 2 vols. Leipzig: Teubner, 1893–1895.
- Terzaghi, Nicola (ed.), Ferdinando Carlesi (trans.), 1983. Apuleio, *Metamorphoseon libri XI*. Firenze: Sansoni. ¹1954.
- Thapar, Romila, 1966. *A History of India*. Vol. I. Harmondsworth, Middlesex: Penguin, 1966.
- Thompson, Stith, 1946. *The Folktale*. New York: The Dryden Press.
- Unguru, Sabetai, 1975. "On the Need to Rewrite the History of Greek Mathematics". *Archive for History of Exact Sciences* **15**, 67–114.
- Unguru, Sabetai, & David E. Rowe, 1981. "Does the Quadratic Equation Have Greek Roots? A Study of »Geometric Algebra«, »Application of Areas«, and Related Problems". I: *Libertas Mathematica* **1** (1981), 1–49; II: **2** (1982), 1–62.
- van der Waerden, B. L., 1962. *Science Awakening*. 2nd Edition. Groningen: Noordhoff. ¹1954.
- van der Waerden, B. L., 1979. *Die Pythagoreer. Religiöse Bruderschaft und Schule der Wissenschaft*. Zürich & München: Artemis Verlag, 1979.
- van Egmond, Warren, 1980. *Practical Mathematics in the Italian Renaissance: A Catalog of Italian Abacus Manuscripts Manuscripts and Printed Books to 1600*. (Istituto e Museo di Storia della Scienza, Firenze. Monografia N. 4). Firenze: Istituto e Museo di Storia della Scienza.
- Vogel, Kurt, 1930. "Die algebraischen Probleme des P. Mich. 620". *Classical Philology* **25**, 373–375.
- von Soden, Wolfram, 1952. "Zu den mathematischen Aufgabentexten vom Tell Harmal". *Sumer* **8**, 49–56.
- Whiting, Robert M., 1984. "More Evidence for Sexagesimal Calculations in the Third Millennium B.C." *Zeitschrift für Assyriologie und Vorderasiatische Archäologie* **74**, 59–66.

Witmer, T. Richard (ed., trans.), 1968. Girolamo Cardano, *The Great Art or The Rules of Algebra*. Cambridge, Mass., & London: M.I.T. Press.

Zeuthen, Hieronimus Georg, 1886. *Die Lehre von den Kegelschnitten im Altertum*. København.