

Assessment of Prevalence and Heterogeneity of Meso- and Microplastic Pollution in Icelandic Waters

Ovide, Belén García ; Cirino, Erica; Basran, Charla Jean ; Geertz, Torsten; Syberg, Kristian

Published in:
Environments

DOI:
[10.3390/environments9120150](https://doi.org/10.3390/environments9120150)

Publication date:
2022

Document Version
Publisher's PDF, also known as Version of record

Citation for published version (APA):
Ovide, B. G., Cirino, E., Basran, C. J., Geertz, T., & Syberg, K. (2022). Assessment of Prevalence and Heterogeneity of Meso- and Microplastic Pollution in Icelandic Waters. *Environments*, 9(12), 150. Article 150. <https://doi.org/10.3390/environments9120150>

General rights

Copyright and moral rights for the publications made accessible in the public portal are retained by the authors and/or other copyright owners and it is a condition of accessing publications that users recognise and abide by the legal requirements associated with these rights.

- Users may download and print one copy of any publication from the public portal for the purpose of private study or research.
- You may not further distribute the material or use it for any profit-making activity or commercial gain.
- You may freely distribute the URL identifying the publication in the public portal.

Take down policy

If you believe that this document breaches copyright please contact rucforsk@kb.dk providing details, and we will remove access to the work immediately and investigate your claim.

Communication

Assessment of Prevalence and Heterogeneity of Meso- and Microplastic Pollution in Icelandic Waters

Belén García Ovide ^{1,*}, Erica Cirino ², Charla Jean Basran ³, Torsten Geertz ⁴ and Kristian Syberg ⁵¹ Ocean Missions NGO, Hafnarstétt 3, 640 Húsavík, Iceland² Plastic Pollution Coalition, 4401A Connecticut Avenue NW #143, Washington, DC 20008, USA³ Húsavík Research Centre, University of Iceland, Hafnarstétt 3, 640 Húsavík, Iceland⁴ Ekspedition Plastik, Rialtovej 19, 2300 København S, Denmark⁵ Department of Science and Environment, Roskilde University, 4000 Roskilde, Denmark

* Correspondence: belen.oceanmissions@gmail.com; Tel.: +35-48410906

Abstract: Surface water samples were collected using a low-tech aquatic debris instrument (LADI) at six nearshore locations on the north and northwestern coasts of Iceland to investigate the prevalence of mesoplastic (5–10 mm) and microplastic (0.3–5 mm) in the region. This sampling strategy involved sampling each transect three times for a total of 18 samples collected in order to assess uncertainties related to heterogeneous distribution of plastic in surface waters. Samples in all six nearshore locations contained meso- and/or microplastic, though concentrations were highly variable. Visual, physical, and FTIR analyses were performed on 71 suspected plastic particles collected, confirming and identifying 40 of those particles as one of six types of plastic: polypropylene (PP), polyethylene (PE), high-density polyethylene (HDPE), polyester, low-density polyethylene (LDPE), and polyvinyl chloride (PVC). Lines originating from fishing gear were the most prevalent types of plastic detected across the samples. This study is among the first to quantify and identify microplastic particles collected in Icelandic nearshore surface waters.

Keywords: microplastic; low-tech aquatic debris instrument (LADI); Iceland; surface waters



Citation: Ovide, B.G.; Cirino, E.; Basran, C.J.; Geertz, T.; Syberg, K. Assessment of Prevalence and Heterogeneity of Meso- and Microplastic Pollution in Icelandic Waters. *Environments* **2022**, *9*, 150. <https://doi.org/10.3390/environments9120150>

Academic Editors: Ioannis K. Kalavrouziotis, Teresa A. P. Rocha-Santos and Ana Luísa Patrícia da Silva

Received: 23 September 2022

Accepted: 26 November 2022

Published: 30 November 2022

Publisher's Note: MDPI stays neutral with regard to jurisdictional claims in published maps and institutional affiliations.



Copyright: © 2022 by the authors. Licensee MDPI, Basel, Switzerland. This article is an open access article distributed under the terms and conditions of the Creative Commons Attribution (CC BY) license (<https://creativecommons.org/licenses/by/4.0/>).

1. Introduction

Since the 1970s, plastic particles, now classified as mesoplastic (5 mm–10 mm), microplastic (1 µm–5 mm) [1], and nanoplastic (<1 µm), have been near-ubiquitously detected across Earth's various ecological compartments [2]. These compartments include soil and sediments [3], glacial ice [4], freshwater bodies, freshwater and marine sediments [5], plants [6], animals [7], humans [8], and marine surface waters [9]. Today, microplastic pollution is a major and growing ecological concern in the ocean and other aquatic environments, including in remote places far from highly populated areas, such as the global sub-arctic region in which Iceland is located [10]. As a pragmatic approach to collecting data on microplastics in marine environments worldwide, research has largely been conducted using surface trawls such as the “manta trawl” [11].

In Iceland, microplastics have been found in the bodies of wildlife including northern fulmars (*Fulmarus glacialis*) [12], blue mussels (*Mytilus edulis*) [13], and fin whales (*Balaenoptera physalus*) [14]. Scientists in Iceland have also identified microplastics in ice cores taken from glaciers, in some drinking water sources sampled around the country [15], and in marine sediments off Iceland's coasts [16]. In August 2021, the Arctic Monitoring and Assessment Program (AMAP) published its “Littering and Microplastics: Monitoring Guidelines Version 1.0,” which outlined current best practices for studying the presence of microplastics across ecological compartments in the arctic region (including Iceland) based on existing research. The comprehensive guidelines, which present the most up-to-date research on plastic in the Arctic, demonstrate that there is a lack of research and data

available on meso- and microplastic concentrations in Iceland's nearshore waters—and thus, the risks microplastic might pose [17].

While studies on meso- and microplastics in the Icelandic marine environment are still in early development stages, macro-plastic-related research in Iceland is growing, with long-term plastic monitoring projects being initiated as recently as 2016 [18]. A recent study conducted in the Atlantic Ocean reveals that oceanic islands are particularly exposed to the threat of microplastic pollution due to the complexity of the coastal ecosystems and the interaction between biotic and abiotic compartments [19]. Preliminary research has found that fishing gear appears to be one of the most commonly identified plastic types found in remote Icelandic beaches [20–22], indicating nets and ropes could be one of the main contributors to microplastic pollution [23] in the Icelandic marine environment.

One potential reason for the lack of research on meso- and microplastics in Iceland's marine environment is that the country's nearshore conditions can be highly variable, with strong winds, precipitation, and a variety of water currents possibly affecting dispersal of microplastics [24] and access to data collection. Researchers have suggested at least 12 physical processes governing the transport of floating plastic debris, including vertical mixing, extreme weather events, and Langmuir circulation [25], particularly in the Arctic regions [16]. These dynamic natural processes appear to disperse meso- and microplastics and may introduce variability in the results from sampling of local concentrations in marine surface waters using a trawl.

Microplastics are known to pose various threats to wildlife, people, and possibly biogeochemical ocean processes [26]. Ingestion of microplastics by marine fauna is of particular concern in Icelandic waters, especially for filter feeders, ranging from blue mussels (*Mytilus edulis*) [27] to large baleen whales, including endangered blue whales (*Balaenoptera musculus*), that feed in these nutrient rich waters [28]. Animals are attracted to eating plastic particles for a variety of reasons. Some aquatic animals, such as fish, have been known to visually mistake plastic particles for food sources (e.g., plankton or fish eggs) [29]. Other animals have a chemical attraction that urges them to consume bio-fouled particles [30], while others inadvertently consume particles during filter feeding [31].

This study reports the first findings from surface trawls conducted in Icelandic waters. The current study aims to contribute to a long-term monitoring campaign in the region to investigate the presence and distribution of meso- and microplastics and the potential effects on marine biota, and thus provides an important first assessment of meso- and microplastic pollution in Icelandic waters.

2. Materials and Methods

2.1. Low-Tech Aquatic Debris Instrument (LADI)

The low-tech aquatic debris instrument (LADI) used for this experiment was constructed in accordance with a guide published by Civic Laboratory for Environmental Action Research (CLEAR), selecting a 38 × 34 × 12.5 cm opening for the wooden frame, and a nylon 333 µm mesh net with a cod end. The LADI used for this experiment was made of gray polyvinyl chloride (PVC) pipe and wood, with metal fastening components, and was secured to the ship using black and white synthetic marine rope, made of polypropylene (PP). The nylon mesh, PVC pipe, and PP ropes were noted as a potential source of contamination in the LADI trawl samples collected. The LADI is considered an accessible and acceptable scientific tool that can be used to estimate local concentrations of meso- and microplastics in surface waters (i.e., the detection of microplastics in lakes by Bashir et al.) [32]. It is similar to the commonly used low-speed manta trawl, and is pulled alongside a ship at a speed of three knots or less for a given duration of time [33]. Compared with a manta trawl, a LADI is a smaller, less expensive (\$500), and easy to build open-source alternative to the current scientific standard, the Manta Trawl, which is expensive (\$3500), heavy, and requires specialized equipment and skills to create", according to its developers at the Civic Laboratory for Environmental Action Research (Figure 1).

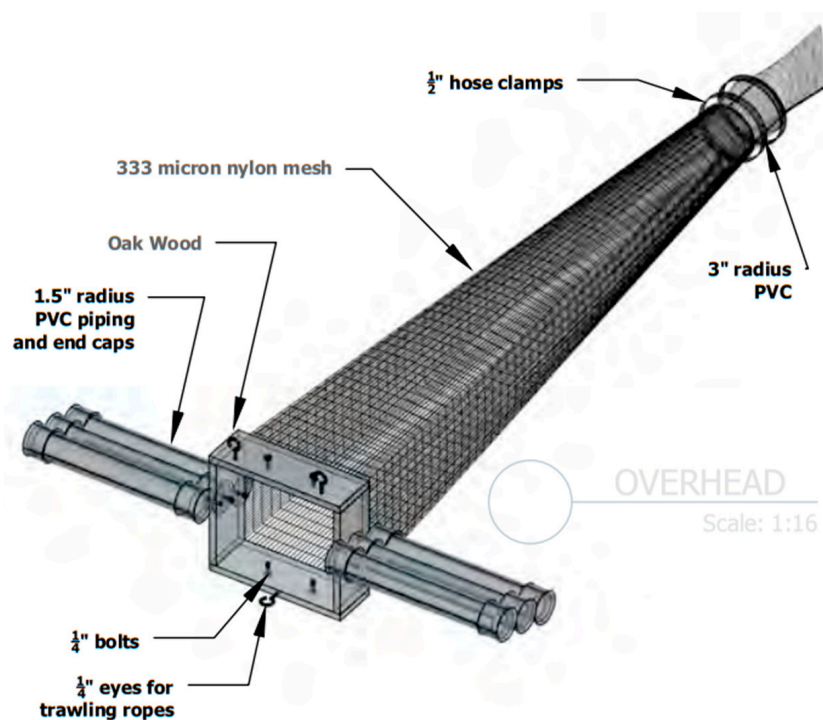

Figure 1. Conceptual drawing of LADI (CLEAR, 2016).

Typically, when employing a LADI or manta trawl, the protocol involves navigating a ship over a measured transect, with GPS coordinates taken at sampling device deployment and retrieval [34]. GPS coordinates are used to establish sample region distance, which can be used with data on plastic quantity to extrapolate concentration over a given area of sea. Our study assesses LADI samples collected in replicates in order to address the uncertainty that is associated with surface sampling of heterogeneously distributed microplastics in Iceland's dynamic marine environment.

2.2. Sample Collection

Samples were collected during a sailing cruise from Reykjavík to Húsavík, Iceland, on board SV Ópal, a 24 m wooden hybrid-electric-powered schooner, as part of an expedition carried out by Iceland-based non-governmental organization Ocean Missions (www.oceanmissions.org) (accessed on 24 April 2019). The LADI was deployed from the port side of SV Ópal for approximately 30 min per sample on a sea state < 3 on the Beaufort scale, traveling a total of approximately a 3.7×3 km area of sea. The exact duration of trawling time varied, as deployment is dependent on favorable sea conditions and weather. In an effort to test for potential variability in meso- and microplastic concentrations, and to increase the accuracy of concentration estimates, we used a novel repeat transect survey strategy. We sampled six nearshore areas around the west and northwest coasts of Iceland, three times each using a zig-zag pattern (Figure 2).

Coordinates were taken using the ship's onboard GPS system at start and end of each sampling transect. The SV Ópal traveled between 1.8 and 3 knots, for 28 to 38 min, while the LADI was deployed at each of the six sampling locations. Sea states varied from 1 with swell to 3 (Beaufort scale), and wind speed ranged from 1 to 4 knots. Distance and area covered by each trawl were measured using sailing speed and a digital GPS unit onboard.

Immediately after each trawl was completed, the contents of each cod end were rinsed with freshwater and filtered through two sieves with a mesh size of 1 mm and 0.3 mm. A measuring grid was then used to sort the particles by size into two categories: macro/mesoplastic (>5 mm) and microplastics (0.33 mm–5 mm) following existing protocols for the monitoring and assessment of plastic litter and microplastics in the ocean [35,36]. During the sampling and sample preparation, only plastic fibers smaller than the targeted

sampling size were found in procedural blanks ensuing minimal risk of contamination. Visually identifiable biological materials, including plankton, kelp, and fish eggs were removed during the analysis and returned to the water. Suspected plastic particles were selected visually and confirmation was aided by examination under a stereo microscope and the use of a hot needle test to distinguish microplastics from other non-plastic particles. All suspected microplastic particles were measured, counted, and stored in paper pouches with no light exposure to prevent photodegradation. Particles of ambiguous material were also collected for spectroscopic testing. All samples were shipped to Roskilde University in Denmark for further analysis.

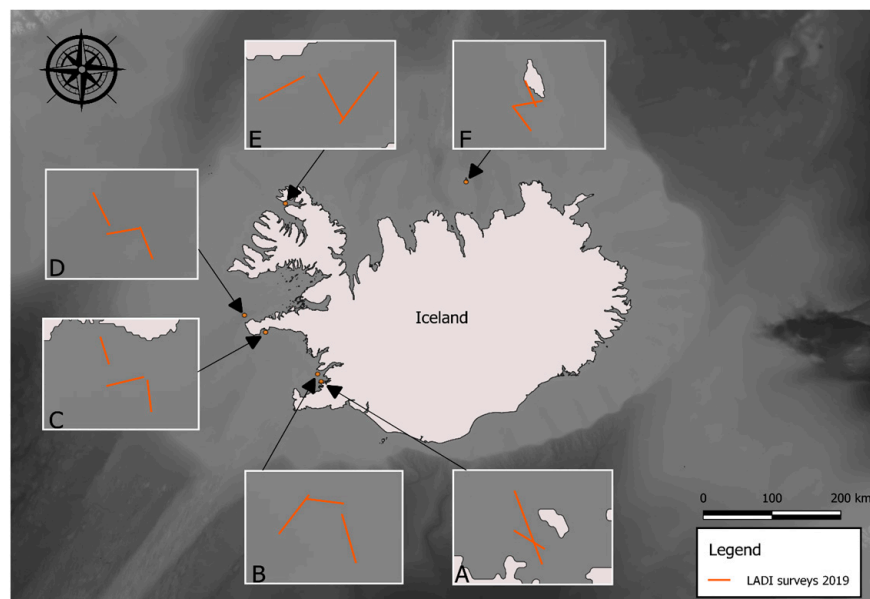

Figure 2. Map of locations of each trawl (A–F). The boxes show where the samplings were conducted along the route and further illustrate the specific “zig-zag” path used during each sampling. Sample regions: Reykjavík (A), Faxaflói (B), Arnarstapi (C), Snæfellsnes (D), Ísafjörður (E), and Grímsey (F).

2.3. Characterization of Polymer Composition

Using attenuated total reflection–Fourier-transform infrared (ATR–FTIR) spectroscopy, composition of the surface layer (1–2 μm) of each of the collected plastic particles was determined. Using a PerkinElmer Spectrum two spectrometer, a single bounce diamond internal reflectance element ($2 \times 2 \text{ mm}$) was employed to run 71 scans at a resolution of 2 cm^{-1} between 4000 and 650 cm^{-1} . Characterization was based on a minimum 70% match with reference spectra, as well as manual assessment of compliance with peaks within the 1400 – 4000 cm^{-1} part of the spectra (Figure 3). Samples appeared fairly clean upon inspection, with minor amounts of biofouling, and so were simply rinsed in fresh water, dried at air temperature, and then stored in glass petri dishes for the duration of the analysis. A clean, empty glass petri dish was placed on the lab bench at the start of each inspection in the laboratory and examined for presence of microplastic following the end of each inspection session. Lab control ensured that any potential contamination of samples in the lab could be accounted for. Non-synthetic clothing was worn to prevent contamination.

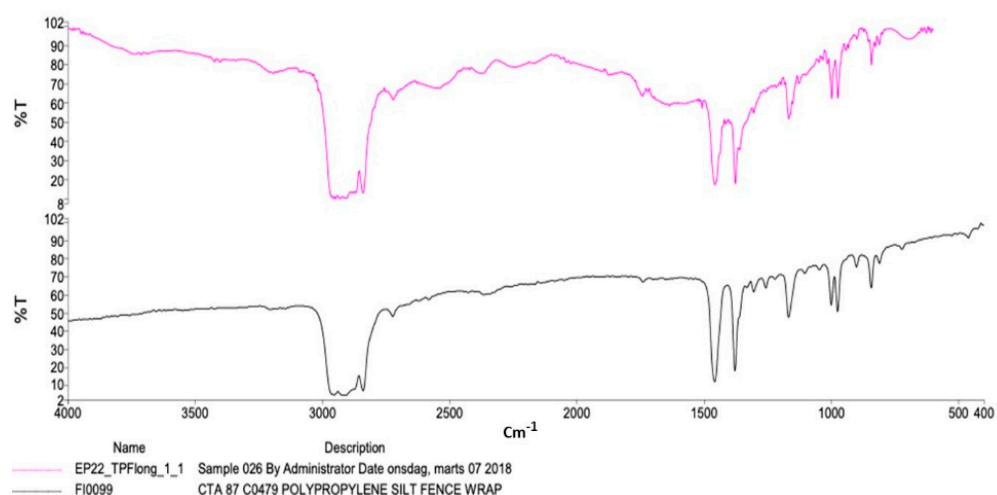

Figure 3. FTIR spectra of a polypropylene line sampled during the expedition (purple spectra). All samples were compared with a reference library developed over several years, containing both pristine spectra and spectra from samples of plastic collected in marine, freshwater, and terrestrial environments in Europe, Africa (including coastal waters), the Atlantic Ocean, and the Pacific Ocean (black spectra).

3. Results

3.1. Abundance

A total of 18 surface trawls were conducted, covering a total distance of 48,764 m with a trawling area of 16.581 m² (Table 1). The average distance covered by trawls was 2709 m ± 254 m (mean ± SD).

Waters in all six sample locations collectively contained meso- and/or microplastics, though not every LADI transect yielded plastic. Of 18 samples taken in total, 8 contained zero meso- or microplastic particles. Concentrations of plastic particles were highest at the Arnastapi and Snæfellsnes sampling sites which are also among the most remote areas within the sampled locations. However, the high mean concentration of plastic particles found at the Arnastapi site was heavily influenced by the first two samples taken, as the last sample contained 0 visible plastic particles. Sample variability may be explained by ocean currents, wind, or other natural phenomena that transport plastic particles through Earth's compartments. In order to compare the concentrations at the different sampling sites, data were normalized to particles/km² using the equation:

$$\text{particles per km}^2 \text{ of sea surface} = \frac{\text{total number of plastic particles}}{\text{distance covered} \times \text{LADI mouth width (km)}}$$

It should be noted that this is a typical calculation method, though the result is a theoretical particle density per area based on the relatively low numbers of plastics obtained in our samples.

For the Reykjavík sampling site, the average calculated meso-/microplastic concentration (mean (min. max.)) was 1025.4 (1066–2010) particles/km²; for the Faxaflói sampling site: 756.3 (0–2269) particles/km²; for the Arnastapi sampling site: 6189.3 (0–12,214) particles/km²; for the Snæfellsnes sampling site: 6098.3 (3737–7941) particles/km²; for the Ísafjörður sampling site: 407 (0–1221) particles/km²; and for the Grímsey sampling site: 324.6 (0–974) particles/km².

Table 1. Overview of results. For each station the total MPs, distance trawled, theoretical abundance per km², mean MPs per location, and sea state are provided.

Location	Start	End	Distance Traveled (m)	Sea State	Total MP	MP/km ²
Reykjavík (A)	64 09.25 N	64 10.58 N	2926	2	2	2010
	21 54.87 W	21 56.67 W	2759		1	1066
			2593	2	0	0
Mean MPs/km ²						1025.4
Flaxaflói (B)	64 13.79 N	64 14.96 N	2593	3	2	2269
	22 00.68 W	22 02.15 W	2445	3	0	0
			2611	3	0	0
Mean MPs/km ²						756.3
Arnastapi (C)	64 44.25 N	64 45.45 N	2408	1 + swell	10	12,214
	23 25.59 W	23 26.24 W	2778	1 + swell	6	6352
			2778	1 + swell	0	0
Mean MPs/km ²						6189.3
Snæfellsnes (D)	64 56.95 N	64 58.59 N	3148	1 + swell	4	3737
	24 02.47 W	24 03.52 W	2222	1 + swell	5	6617
			2593	1 + swell	7	7941
Mean MPs/km ²						6098.3
Ísafjörður (E)	66 16.34 N	66 16.76 N	2408	3	1	1221
	22 59.79 W	22 56.72 W	2963	3	0	0
			3148	2	0	0
Mean MPs/km ²						407
Grímsey (F)	66 31.93 N	66 30.73 N	2593	3	0	0
	18 01.28 W	17 59.54 W	3019	4	1	974
			2778	4	0	0
Mean MPs/km ²						324.6

Average concentrations of meso-/microplastics at Arnastapi and Snæfellsnes were markedly higher than at the remaining sampling sites. However, we observed considerable variance in the number of plastic particles picked up during each LADI transect, within each nearly identical sample area. Even though there seems to be a difference between sites, the huge deviations due to the heterogenic nature of plastic particle makes it difficult to assess whether these differences are a result of variation between sites or variation within each site, as indicated by the large differences between minimum and maximum theoretical abundance calculated for each transect.

3.2. Characteristics of Plastic Samples

A total of 40 plastic particles were identified as plastic using FTIR, out of a total of 71 particles that were pre-selected from samples by researchers as possible plastic particles. Twenty-one plastic particles could be classified as mesoplastic (>5 mm) while 19 could be classified as microplastic (0.33–5 mm). The total number of plastic particles found ($n = 40$) were classified as: fragments ($n = 12$), films ($n = 5$), and lines ($n = 23$). Based on FTIR analysis, detected types of plastic included PP ($n = 19$), PE ($n = 6$), HDPE ($n = 5$), polyester ($n = 2$), LDPE ($n = 4$). Four fragments of gray PVC were detected.

The color and composition of the PVC particles led to the conclusion that they were likely shed from the LADI, which was constructed using similarly colored PVC. The FTIR spectrometer detected plasticizer chemicals in three particles collected, including polydiallyl phthalate ($n = 1$) and diacetylphthalate ($n = 2$), though not plastic.

4. Discussion

The large variances in microplastic concentrations illustrate one of the issues with collecting surface samples of plastics particles, specifically in areas that are not considered hotspots with very high concentrations. The relatively low concentrations and heterogenic

dispersion implies that very few particles can alter the results significantly (e.g., the theoretical concentrations at the Reykjavík sampling site were 2010, 1066, or 0 particles/km², if estimates were made based on just one of the three transects). One solution could be to conduct the sample over a longer time period doing more zig-zag trawls over an area, but this would not eliminate the large variability that is inherent to these types of samples.

The highest presence of meso-/microplastics coinciding with the sparsely inhabited sampling areas supports the theory that dispersal factors such as weather and currents have an important influence on particle dispersal and distribution in the Arctic and the results from this study support this specifically in Icelandic coastal waters for the first time.

PP and PE lines, commonly used for fishing lines and as a component of marine ropes, were the most prevalent types of plastic detected across the samples, found in particular abundance at the Arnastapi and Snæfellsnes sampling sites. PP and PE lines together made up 50% ($n = 20$) of all plastic particles found and identified. It appears some of the PP line could have shed from the synthetic rope used to secure the LADI trawl. Five of the PP lines found were white, like the ropes used on the research vessel. However, given Iceland is a major fishing nation worldwide [37], the predominance of lines also suggests that Iceland's fishing industry is a key contributor to meso-/microplastic in the country's nearshore waters. There were 1647 registered fishing vessels in Iceland in 2020, bringing in a total catch of 1,030,594 metric tons to 58 ports [38]. The vast majority of these vessels are bottom trawlers using plastic fishing gear to catch cod, and research by Loughlin, C. et al., 2021, shows higher microplastic abundance in sediments of the most heavily fished areas [16]. These results support the findings from previous studies that reported the prevalence of microplastics coming from marine-based sources (i.e., fishing activities) in the Atlantic Ocean basin [39]. Arnastapi and Snæfellsnes are important local fishing grounds which may explain the higher number of PP and PE lines in these areas.

The next most common categories of plastic particles were PP fragments at 12.5% ($n = 5$), polyester lines at 5% ($n = 2$), LDPE film at 7.5% ($n = 3$), PP film at 2.5% ($n = 1$), and HDPE fragments at 10% ($n = 4$). Only one fragment of LDPE ($n = 1$), 2.6% of the sample, was identified. PP, HDPE, and LDPE are commonly used in packaging and in single use plastic items. None of the plastic pieces appeared shed from the ship itself, which had green, white, blue, and red synthetic paint. Four fragments of gray PVC, 10% ($n = 4$), perhaps shed from the LADI trawl, were detected.

This work highlights an issue with standard sampling methods for microplastic in surface waters using a LADI or manta trawl, by indicating that microplastic yields in samples taken at a specific location seems to fluctuate across samples, sometimes by a notable amount. Even though other studies provide measures of uncertainty, they are typically collected with a single transect per area explored [40]. This uncertainty is most important in areas with low concentrations of microplastics, since a deviation of a few particles that by chance end up in the net can have a large influence of the calculated average concentrations in the area.

The Icelandic marine environment is especially complex. Like other arctic marine ecosystems, those around Iceland are subject to extremes—such as storms, wind, water currents, and temperature [41]. To the best of our knowledge, our microplastic data are the first collected in Icelandic nearshore surface waters using a LADI, demonstrating both the benefits and drawbacks of an accessible and affordable research tool in collecting microplastic samples from marine surface waters.

5. Conclusions

In this study we show that a LADI trawl can be used to collect data on the presence of meso-/microplastic particles in Icelandic nearshore waters. The varying levels of meso-/microplastic observed demonstrated the heterogeneous distribution of plastic particles in the dynamic sub-arctic marine environment. It might be possible to improve microplastic sampling methods in surface waters by taking a greater number of repeated transects over each of the study areas to account for heterogeneity caused by local marine and atmospheric

conditions. Taking samples seasonally and year after year is suggested to help discern potential patterns in microplastic composition, count, and distribution. Lastly, sampling for microplastics within the water column, in seafloor sediments, in marine plants, and in the tissues of marine animals would help understand the fate of plastic particles in the Icelandic marine nearshore environment [42].

The predominance of PE and PP lines commonly used in fishing in the collected samples suggests intensive fishing activities in the sub-arctic region are likely contributing to the presence of plastic in Icelandic waters. Standardized methods and synchronized efforts in Iceland could greatly help to minimize the uncertainty of the study of meso-/microplastics pollution in this marine complex environment. Based on present knowledge of the issue, it seems weather plays a significant role in the continual transport of plastic particles throughout the natural environment [25]. Compared with the other sampling sites, the coast of Arnastapi and Snæfellsnes is clearly under the influence of the Icelandic Coastal Current (ICC) and Icelandic Coastal Undercurrent (ICUC). This could be one of the explanations for the higher number of particles in those locations. One suggestion to investigate how these localized currents affect the dispersal of particles could be to integrate the microplastic data into a hydrodynamic model for Icelandic waters and monitoring the weather conditions [39].

Considering the lack of research on microplastic pollution in Iceland and in light of the increasing pressure worldwide for the governments to take actions on solving the plastic pollution crisis, further monitoring of microplastics (presence, abundance, types, and dispersion) in Icelandic coastal waters is essential to better understand the issues that threaten the fragile sub-arctic marine ecosystems. Furthermore, it is imperative to develop greater awareness about the plastic pollution issue in sparsely inhabited and vulnerable sub-arctic areas. Thus, we recommend future research that aims at understanding why huge variations in microplastic abundances are found in different compartments of the natural environment, including in Iceland's nearshore surface waters.

At the local scale, it would be beneficial to understand why the irregularities in microplastic count within the same transect occur within just 30 min to an hour of each other in Icelandic sampling sites.

Overlapping these data with identified and localized natural phenomena and factors that could affect distribution and concentration of microplastic in marine regions, such as surface currents and wind patterns, as well as fishing activities, could potentially shed additional, useful light on the fate of microplastics in the sub-arctic ecosystem. Doing so may also help establish a better understanding of where plastic particles ultimately travel—and how great of a risk the particles may pose to people living in Iceland and to sub-arctic marine wildlife.

Author Contributions: Conceptualization, K.S.; investigation and structure, T.G. and E.C.; data curation, E.C., B.G.O. and C.J.B.; writing—original draft preparation, E.C.; writing—review and editing, B.G.O., K.S., E.C. and C.J.B.; visualization, B.G.O.; supervision, B.G.O., C.J.B. and K.S. All authors have read and agreed to the published version of the manuscript.

Funding: This research received no external funding.

Data Availability Statement: The data presented in this study are available in [<https://oceanmissions.org/wp-content/uploads/OM-REPORT-2019.pdf>].

Acknowledgments: We wish to thank the crew onboard the SV Ópal, and North Sailing for their invaluable participation in the expedition. Special thanks to Enorha Guimard for her support on this publication and the University of Roskilde in Denmark for providing access to the data analysis in the laboratory.

Conflicts of Interest: The authors declare no conflict of interest.

References

1. Hartmann, N.B.; Hüffer, T.; Thompson, R.C.; Hassellöv, M.; Verschoor, A.; Daugaard, A.E.; Rist, S.; Karlsson, T.M.; Brennholt, N.; Cole, M.; et al. Are we speaking the same language? Recommendations for a definition and categorization framework for plastic debris. *Environ. Sci. Technol.* **2019**, *53*, 1039–1047. [CrossRef]
2. Carpenter, E.J.; Smith, K.L., Jr. Plastic on the Sargasso Sea surface. *Science* **1972**, *175*, 1240–1241. [CrossRef] [PubMed]
3. Wang, J.; Liu, X.; Li, Y.; Powell, T.; Wang, X.; Wang, G.; Zhang, P. Microplastics as Contaminants in the Soil Environment: A Mini-Review. *Sci. Total Environ.* **2019**, *691*, 848–857. [CrossRef] [PubMed]
4. Ambrosini, R.; Azzoni, R.S.; Pittino, F.; Diolaiuti, G.; Franzetti, A.; Parolini, M. First Evidence of Microplastic Contamination in the Supraglacial Debris of an Alpine Glacier. *Environ. Pollut.* **2019**, *253*, 297–301. [CrossRef]
5. Eerkes-Medrano, D.; Thompson, R.C.; Aldridge, D.C. Microplastics in Freshwater Systems: A Review of the Emerging Threats, Identification of Knowledge Gaps and Prioritization of Research Needs. *Water Res.* **2015**, *75*, 63–82. [CrossRef]
6. Fogašová, K.; Manko, P.; Oboňa, J. The first evidence of microplastics in plant-formed fresh-water micro-ecosystems: *Dipsacus teasel* phytotelmata in Slovakia contaminated with MPs. *BioRisk* **2022**, *18*, 133. [CrossRef]
7. Susanti, N.K.Y.; Mardiasuti, A.; Wardiatno, Y. Microplastics and the Impact of Plastic on Wildlife: A Literature Review. *IOP Conf. Ser. Earth Environ. Sci.* **2020**, *528*, 012013. [CrossRef]
8. Kannan, K.; Vimalkumar, K. A review of human exposure to microplastics and insights into microplastics as obesogens. *Front. Endocrinol.* **2021**, *12*, 978. [CrossRef] [PubMed]
9. Eriksen, M.; Lebreton, L.C.M.; Carson, H.S.; Thiel, M.; Moore, C.J.; Borerro, J.C.; Galgani, F.; Ryan, P.G.; Reisser, J. Plastic pollution in the world's oceans: More than 5 trillion plastic pieces weighing over 250,000 tons afloat at sea. *PLoS ONE* **2014**, *9*, e111913. [CrossRef] [PubMed]
10. Peeken, I.; Primpke, S.; Beyer, B.; Gütermann, J.; Katlein, C.; Krumpfen, T.; Bergmann, M.; Hehemann, L.; Gerdt, G. Arctic Sea ice is an important temporal sink and means of transport for microplastic. *Nat. Commun.* **2018**, *9*, 1505. [CrossRef]
11. Karlsson, T.M.; Kärrman, A.; Rotander, A.; Hassellöv, M. Comparison between manta trawl and in situ pump filtration methods, and guidance for visual identification of microplastics in surface waters. *Environ. Sci. Pollut. Res.* **2020**, *27*, 5559–5571. [CrossRef] [PubMed]
12. Linnebjerg, J.F.; Baak, J.E.; Barry, T.; Gavrilov, M.V.; Mallory, M.L.; Merkel, F.R.; Price, C.; Strand, J.; Walker, T.R.; Provencher, J.F. Review of plastic pollution policies of Arctic countries in relation to seabirds. *FACETS* **2021**, *6*, 1–25. [CrossRef]
13. SeaIceland. Available online: <https://seaiceland.is/what/gastropods/sea-shells/mussels> (accessed on 13 April 2022).
14. Vernet, R.G.; Borrell, A.; Víkingsson, G.; Halldórsson, S.D.; Aguilar, A. Ecological niche partitioning between baleen whales inhabiting Icelandic waters. *Prog. Oceanogr.* **2021**, *199*, 102690. [CrossRef]
15. McQuilkin, J.V.; Böhme, L.; Alinaghizadeh, B.I.; Proietti, N.M. Microplastic in drinking water sources and distribution systems in Iceland. *Resour. Int. Ehf.* **2021**. Available online: <https://www.resource.is/wp-content/uploads/2020/01/Microplastics-in-drinking-water-sources-and-distribution-systems-in-Iceland.pdf> (accessed on 1 April 2022).
16. Loughlin, C.; Mendes, A.R.M.; Morrison, L.; Morley, A. The role of oceanographic processes and sedimentological settings on the deposition of microplastics in marine sediment: Icelandic waters. *Mar. Pollut. Bull.* **2021**, *164*, 111976. [CrossRef] [PubMed]
17. AMAP. *Litter and Microplastics Monitoring Guidelines, Version 1.0*; Arctic Monitoring and Assessment Programme (AMAP): Tromsø, Norway, 2021; p. 257.
18. Umhverfisstofnun. Niðurstöður Vöktunar Stranda 2004–2019. 2020. Available online: <https://www.ust.is/library/sida/haf-og-vatn/V%c3%b6ktun%20stranda%202016-2019.pdf> (accessed on 12 May 2022).
19. Monteiro, R.C.; Sul, J.A.I.D.; Costa, M.F. Plastic pollution in islands of the Atlantic Ocean. *Mar. Pollut. Bull.* **2018**, *238*, 103–110. [CrossRef]
20. Kienitz, A.T. Marine Debris in the Coastal Environment of Iceland's Nature Reserve, Hornstrandir: Sources, Consequences and Prevention Measures. Master's Thesis, University of Akureyri, Akureyri, Iceland, 2013. Available online: [https://skemman.is/bitstream/1946/15898/4/Anna-Theresa%20Kienitz%20\(3\).pdf](https://skemman.is/bitstream/1946/15898/4/Anna-Theresa%20Kienitz%20(3).pdf) (accessed on 11 February 2022).
21. Hafrannsóknarstofnun. Plast í Hafinu við Ísland. 2019. Available online: <https://www.hafogvatn.is/is/moya/news/rannsoknir-hafrannsoknarstofnunar-a-plasti-i-hafi> (accessed on 15 December 2021).
22. O'Rourke, A. Occurrence, Prevalence, and Classification of Fishing Related Marine Debris in Iceland's Westfjords. Master's Thesis, University of Akureyri, Akureyri, Iceland, 2020. Available online: <https://skemman.is/handle/1946/34986> (accessed on 13 March 2022).
23. Ovide, B.G.; Basran, C.; Guimard, E. Ocean Missions Impact report 2020–2021. 2021. Available online: <https://oceanmissions.org/wp-content/uploads/final-impact-report-2020-2021.pdf> (accessed on 25 May 2022).
24. Ólafsson, H.; Furger, M.; Brümmer, B. The weather and climate of Iceland. *Meteorol. Z.* **2007**, *16*, 5–8. [CrossRef]
25. Van Sebille, E.; Aliani, S.; Law, K.L.; Maximenko, N.; Alsina, J.M.; Bagaev, A.; Bergmann, M.; Chapron, B.; Chubarenko, I.; Cózar, A.; et al. The physical oceanography of the transport of floating marine debris. *Environ. Res. Lett.* **2020**, *15*, 023003. [CrossRef]
26. Galloway, T.; Cole, M.; Lewis, C. Interactions of microplastic debris throughout the marine ecosystem. *Nat. Ecol. Evol.* **2017**, *1*, 0116. [CrossRef]
27. Bråte, I.L.N.; Hurley, R.; Lusher, A.; Buenaventura, N.; Hultman, M.; Halsband, C.; Green, N. *Microplastics in Marine Bivalves from the Nordic Environment*; Nordic Council of Ministers: Copenhagen, Denmark, 2020.
28. Garcia-Garin, O.; Aguilar, A.; Vighi, M.; Víkingsson, G.A.; Chosson, V.; Borrell, A. Ingestion of synthetic particles by fin whales feeding off western Iceland in summer. *Sciencedirect* **2021**, *279*, 130564. [CrossRef]

29. Roch, S.; Friedrich, C.; Brinker, A. Uptake routes of microplastics in fishes: Practical and theoretical approaches to test existing theories. *Sci. Rep.* **2020**, *10*, 3896. [[CrossRef](#)] [[PubMed](#)]
30. Procter, J.; Hopkins, F.E.; Fileman, E.S.; Lindeque, P.K. Smells good enough to eat: Dimethyl sulfide (DMS) enhances copepod ingestion of microplastics. *Mar. Pollut. Bull.* **2019**, *238*, 103–110. [[CrossRef](#)]
31. Zantis, L.J.; Bosker, T.; Lawler, F.; Nelms, S.E.; Rorke, R.O.; Constantine, R.; Sewell, M.; Carroll, E.L. Assessing microplastic exposure of large marine filter-feeders. *Sci. Total Environ.* **2022**, *818*, 151815. [[CrossRef](#)]
32. Bashir, A.; Hashmi, I. Detection in influx sources and estimation of microplastics abundance in surface waters of Rawal Lake, Pakistan. *Heliyon* **2022**, *8*, e09166. [[CrossRef](#)] [[PubMed](#)]
33. Coyle, C.; Novaceski, M.; Wells, E.; Liboiron, M. LADI and the trawl. *Civ. Lab. Environ. Action Res.* **2016**, *1*, 15–43.
34. Viršek, M.K.; Palatinus, A.; Koren, Š.; Peterlin, M.; Horvat, P.; Kržan, A. Protocol for Microplastics Sampling on the Sea Surface and Sample Analysis. *J. Vis. Exp.* **2016**, *118*, e55161. [[CrossRef](#)]
35. Cózar, A.; Echevarría, F.; González-Gordillo, J.I.; Irigoien, X.; Úbeda, B.; Hernández-León, S.; Palma, Á.T.; Navarro, S.; García-De-Lomas, J.; Ruiz, A.; et al. Plastic debris in the open ocean. *Proc. Natl. Acad. Sci. USA* **2014**, *111*, 10239–10244. [[CrossRef](#)] [[PubMed](#)]
36. Gesamp. *Guidelines or the Monitoring and Assessment of Plastic Litter and Microplastics in the Ocean*; Kershaw, P.J., Turra, A., Galgani, F., Eds.; GESAMP Joint Group of Experts on the Scientific Aspects of Marine Environmental Protection: London, UK, 2019; Volume 99, p. 130.
37. Gunnlaugsson, S.B.; Valtýsson, H. Sustainability and wealth creation, but no consensus: Recent decades in Iceland’s ITQ-managed fisheries. *Policy* **2022**, *135*, 104836. [[CrossRef](#)]
38. Iceland Responsible Fisheries. A Nation with Fishing in Its Genes. 2020. Available online: <https://www.responsiblefisheries.is/seafood-industry/a-nation-with-fishing-in-its-genes> (accessed on 1 April 2022).
39. Logemann, K.; Ólafsson, J.; Snorrason, Á.; Valdimarsson, H.; Marteinsdóttir, G. The circulation of Icelandic waters—A modelling study. *Ocean Sci.* **2013**, *9*, 931–955. [[CrossRef](#)]
40. Syberg, K.; Knudsen, C.M.; Tairova, Z.; Khan, F.R.; Shashoua, Y.; Geertz, T.; Pedersen, H.B.; Sick, C.; Mortensen, J.; Strand, J.; et al. Sorption of PCBs to Environmental Plastic Pollution in the North Atlantic Ocean: Importance of Size and Polymer Type. *Case Stud. Chem. Environ. Eng.* **2020**, *2*, 100062. [[CrossRef](#)]
41. Carollo, C.; Astin, I. Extreme Events in Ocean Currents through Depth in the Vicinity of the Iceland-Scotland Ridge. In *Oceans '04 MTS/IEEE Techno-Ocean '04 (IEEE Cat. No.04CH37600)*; IEEE: New York, NY, USA, 2004; Volume 4, pp. 2331–2337. [[CrossRef](#)]
42. Everaert, G.; Van Cauwenberghe, L.; De Rijcke, M.; Koelmans, A.A.; Mees, J.; Vandegehuchte, M.; Janssen, C.R. Risk assessment of microplastics in the ocean: Modelling approach and first conclusions. *Environ. Pollut.* **2018**, *242 Pt B*, 1930–1938. [[CrossRef](#)]