

## What is mathematics?

Perspectives inspired by anthropology

Høyrup, Jens

*Published in:*  
The Nature and Development of Mathematics

*Publication date:*  
2017

*Document Version*  
Early version, also known as pre-print

*Citation for published version (APA):*  
Høyrup, J. (2017). What is mathematics? Perspectives inspired by anthropology. In J. W. Adams, P. Barmby, & A. Mesoudi (Eds.), *The Nature and Development of Mathematics: Cross Disciplinary Perspectives on Cognition, Learning and Culture* (pp. 179-196). London & New York: Routledge.

### General rights

Copyright and moral rights for the publications made accessible in the public portal are retained by the authors and/or other copyright owners and it is a condition of accessing publications that users recognise and abide by the legal requirements associated with these rights.

- Users may download and print one copy of any publication from the public portal for the purpose of private study or research.
- You may not further distribute the material or use it for any profit-making activity or commercial gain.
- You may freely distribute the URL identifying the publication in the public portal.

### Take down policy

If you believe that this document breaches copyright please contact [rucforsk@ruc.dk](mailto:rucforsk@ruc.dk) providing details, and we will remove access to the work immediately and investigate your claim.

**WHAT IS MATHEMATICS?**  
**Perspectives inspired by anthropology**

**Contribution to the**  
**Emergent Mathematics Workshop**  
**Durham University, Stockton on Tees, U.K., 16th March 2015**

**Jens Høyrup**  
**Roskilde University**  
**Section for Philosophy and Science Studies**  
jensh@ruc.dk  
<http://ruc.dk/~jensh/>

*PREPRINT*  
23 March 2015

## Abstract

The paper discusses the question “what is mathematics” from a point of view inspired by anthropology. In this perspective, the character of mathematical thinking and argument is strongly affected – almost essentially determined, indeed – by the dynamics of the specific social, mostly professional environments by which it is carried. Environments where future practitioners are taught as apprentices produce an approach different from that resulting from teaching in a school – the latter inviting to intra-mathematical explanation in a way the former does not. Moreover, once the interaction with the early classical Greek philosophical quest for causes and general explanations had caused mathematical explanation to become an autonomous endeavour in the shape of explicit proof and deductivity, proof and deductivity presented themselves as options – sometimes exploited, sometimes not – even in the teaching of mathematics for practitioners.

An introduction . . . . .	1
Practitioners . . . . .	2
Proof . . . . .	9
After the Greeks . . . . .	16
References . . . . .	18

## An introduction

What is mathematics? Is it Euclid, and when really sophisticated, Archimedes, and what they are supposed to stand for? That is, exact proof?

Or is it what mathematicians do? Or, what engineers or carpenters do when planning something?

Or, is it what all of us do when planning certain tasks where the aspects of number and quantity can be dealt with in abstraction from other aspects? For example, what comes into play when I plan to construct some bookshelves, measure the wall where they are to stand, and calculate the dimension of the boards to be used, leaving out of consideration the colour of the wood (and, at my risk, leave their weight and elasticity out of sight, even though these are things an engineer would take into account in corresponding mathematical calculations)?

The preceding suggestions touch at many aspects of our question; dealing with these we shall encounter new questions and new interactions; available space, but only that, will prevent us from continuing indefinitely.

Let us first concentrate on the mathematics that is involved in some kind of professional activity (after all, my non-professional bookshelf calculations are simplified variants of what a carpenter would do).

As a historian I shall look at this in a perspective that reaches back to the Bronze Age, in the hope shared by many historians that this *Verfremdung* will make it easier to understand features of our own situation that are too familiar to be noticed.

This evidently raises the question about the point in history where it is possible to speak about mathematics in a way that makes sense in the present world.

I shall propose absolute no date. Instead, as on earlier occasions (for example, [Høyrup 1994: 67f]), I shall define

the transition to mathematics as the point where *preexistent and previously independent* mathematical practices are coordinated through a minimum of at least intuitively grasped understanding of formal relations. Remaining ambiguities I shall accept as an unavoidable ingredient of human existence.

## Practitioners

It does not follow from this definition but seems to be the case in actual history that the transition occurred only when mathematical techniques were wielded not only by specialists but by specialists who were somehow organized professionally and thus also linked in a network of communication. According to studies of ethnomathematics as defined in [Ascher & Ascher 1986: 125], that is, as “the study of mathematical ideas of non-literate people”,<sup>1</sup> what we may see as an integrated whole and label ethnomathematics in its original context will mostly consist of unconnected mathematical techniques (that is, integrated with other facets of culture but not with each other). This is at least the impression conveyed by for example Paulus Gerdes’ and Marcia Ascher’s publications; we may explain marriage rules and the construction of string- or sand-drawn figures by one and the same group theory, but this is *our* connection. Not everybody in such societies are equally skilled in using the techniques, and those who are particularly skilled may guard their knowledge jealously – see, for example [Gerdes 1997: 32–36]. They may even make up a recognized and respected group; but they do not make their living from that.

*Integrated mathematics* appears to arise with that social complexity and particular division of labour which historically goes together with early state formation and the development of writing or some equivalent recording system like the Inka *quipus*.<sup>2</sup> The case we know best (yet not as well as we would like) is late fourth-millennium BCE southern Mesopotamia. Here, the earliest state-like social system developed in the city Uruk around the large temples. The priesthood of these created a pictographic script and a numerico-metrological

---

<sup>1</sup> It should be remembered that the concept as defined by Ubiratan d’Ambrosio [1987: 15] is quite different (my English translation, as everywhere in the following where nothing else is indicated

Ethnomathematics implies a very broad conceptualization of “ethnic” and of mathematics. Much more than just being associated with ethnicities, “ethnic” refers to identifiable cultural groups, such as national-tribal societies, trade unions and professional groups, children of a certain age group, etc.

while mathematics includes counting, measuring, accounting, classifying, ordering, inferring and modelling. Under this definition, “ethnomathematics” will certainly often encompass integrated mathematics. D’Ambrosio justly characterizes it as “anthropological mathematics” – in principle thus more or less what I am addressing here.

<sup>2</sup> Like early Mesopotamian writing, the *quipus* primarily served accounting and administration, but they could also (in ways we do not understand) encode information about the structure of the state or society [d’Altroy 2015: 6f].

system, the latter used for accounting, the former providing context (“from whom to whom”, etc.) – and the numerico-metrological system bears witness of integration of length- and area metrologies and of a general idea of sub-unit across the various metrologies. [Høyrup 2009: 18–28] presents an overview and further references to the indirect evidence drawn upon.

Use of this body of integrated mathematical knowledge was the privilege of the same stratum of manager-priests that had created it; it was thus carried by a professional group.

According to the way their knowledge is transmitted, such professional groups fall into two main types (as always in such cases, transition forms can be identified; for the sake of clarity I shall stick to the main types). In one type, knowledge is transmitted within an apprenticeship-system of “learning by doing under supervision”. The other type involves some kind of school, that is, teaching separate from actual work.

In the former type, those who transmit are actively involved in the practical activities of their trade; they will tend to train exactly what is needed, and the understanding they will try to communicate will be that of practical procedures – and they will try to make the apprentice work usefully as early as possible.

In pre-modern times, training of the apprenticeship-based type will usually have been “culturally oral” (which does not mean that no practitioners would be able to read and write).<sup>3</sup> However, the early Mesopotamian temple system (whose literacy was anyhow rudimentary and not fit for carrying any communication beyond that of accounts) appears to be an exception in as far as its mathematics teaching is concerned; while writing was trained by means of sign lists, which point to the existence of some kind of school, the only evidence we have of mathematics teaching consists of “model documents”, differing from real administrative documents only by the appearance of suspiciously nice numbers and by the absence of an official’s seal.

School teaching of mathematical skill, on the other hand, in need of a virtual representation of future practice, is – probably by necessity and at least according to historical experience – bound to a writing system extensive enough to carry a literate culture.

Teachers in the school type may well have as their aim to impart knowledge for practice. However, the practice with which professional teachers are most

---

<sup>3</sup> On oral and literate culture types, see various works by Walter Ong – e.g., [1977; 1982] – and Jack Goody – not least, [Goody 1987].

familiar cannot avoid being that of *teaching*. In the case where mathematics is what they teach (at whatever historical and age level) and in case they aim at conveying as much understanding as facilitates learning on part of those who are taught, that understanding will easily concentrate on inner connections of the topic – that is, on *mathematical* explanation.

So much for the moment about teaching types. Another point to take into account is the *nature of professions*. These are groups engaged in a particular niche of the social division of labour – accounting, surveying, cathedral building, dentistry, the administration of law, to mention just a few random possibilities, of which the first three at least involve some wielding of mathematical techniques. But they are also *social* groups kept together not only by similarity of tasks but also by awareness and pride of appurtenance to a group with an expertise that non-members do not possess.

Such expertise, of course, has to be demonstrated, and everyday work will only call for everyday skills – not sufficient to display stunning expertise. In the case where *mathematical* expertise is involved, the need for display gives rise to a request to be able to solve questions apparently pertinent to the chore of the profession but more intricate than what will be encountered in daily practice; perhaps even so artificial that they will *never* turn up in actual practice, and at best so striking that they may impress outsiders – mathematical Eiffel towers, so to speak. I shall refer to them as “supra-utilitarian”. In particular within an apprenticeship-based environment, they will often have the character of genuine riddles, in agreement with the eristic character of oral culture.

As an example we may think of the problem of the “100 fowls”, a merchants’ and accountants’ riddle. In average formulation it might run

I go to the market and buy 100 fowls for 100 coins. I get a goose for 5 coins, a hen for 2 coins, and three sparrows for 1 coin. What did I buy?

There are two solutions (one is 5 geese, 26 hens and 69 sparrows); with other numbers we may get many more. But that does not matter, a riddle is correctly answered by one valid answer.

Such problems are known as “recreational”, but with regard to their original function this is a misnomer. There, in terms familiar to anthropologists, they were “neck riddles” – who can solve them belongs to the group, who cannot will be kept outside.<sup>4</sup> They became matters of recreation once mathematical

---

<sup>4</sup>This explanation at the level of sociology does not contradict an individual motivation from the pleasure of “being able” – the kind of “power” spoken of by Christoph

literacy became widespread (but then new types developed corresponding to the level of mathematical professionals of the new era, cf. below).

Even when such riddles are apparently mathematical, the expected solution need not be mathematically correct, as we sometimes see where such oral riddles are adopted directly into written problem collections. In one, the eighth-century Frankish *Propositiones ad acuendos juvenes* [ed. Folkerts 1978: 47], two merchants are supposed to buy swines and sell them at the same price with a profit. Of course there is a fallacy, but it is easily overlooked. Such mock solutions illustrate that we are really dealing with riddles – we may think of the riddle of the sphinx (neck riddle if ever there was): only by understanding “morning” as “childhood”, “noon” as “adulthood” and “evening” as “old age” is Oedipus able to solve it and save his life.

In any practice making use of mathematical knowledge, *the problem* to be solved is primary, and methods have to be developed and chosen in order to solve it; that is, methods are subordinate. That relation is turned around in the kind of mathematics that serves to display dexterity, professional or otherwise. This holds even today (and not only in mathematics) if you want to display your abilities in order to earn a degree and hopefully get a corresponding position: then, if you are cautious, you choose (or your doctoral advisor responsibly helps you choose) a problem that methods with which you are or can become familiar are liable to attack successfully.

There is, however, a difference between the way in which this quest for impressive display manifests itself in the apprenticeship- and the school-based situation. In an apprenticeship-based system, a small collection of riddles may serve the purpose – the master of the apprentice will not waste time that could be used profitably on systematic training of such matters. That is why the “100 fowls” could circulate between China, India, the Islamic world and Western Europe from the fifth century CE onward, only with the variation in India that 4 species are bought instead of three, and that the *Propositiones ad acuendos juvenes* speak about other kinds of animals.<sup>5</sup>

In a school situation, however, the training of mathematical competence *per se* calls for a systematic approach and thereby also for repetition with variation. That has several consequences, not only in school but also in the professional

---

Scriba [1992]. But only where such individual pleasure is in agreement with sociologically determined forces can it be stabilized as more than an individual accident.

<sup>5</sup> A survey of select appearances will be found in [Tropfke/Vogel et al 198: 613–616].



culture produced by schooling. Firstly, looking for instance at the way the “100 fowls” appear in the Italian late medieval “*abacus* books”,<sup>6</sup> we see that not only the prices but also the number of fowls and the total price vary. Next, it may induce some teachers to look for new problem types that can be solved by the methods at hand and for possible expansions of the range of available methods; both get us close to what may be called research, even though the process could not be conceptualized as such in a world where it did not correspond to a *systematic* effort – actually, the separation of the concept of “[scientific] research” from the general idea of close scrutiny appears to belong to the late 19th or even the early 20th century.<sup>7</sup>

A Mesopotamian example may illustrate and clarify this.<sup>8</sup> Already around 2550<sup>9</sup> BCE, a profession of *scribes* separate from the leading stratum of temple managers had emerged; surveyor-scribes also appear to have formed a distinct group, separate for example from those scribes who would draw up contracts. Before 2300 BCE, it appears that lay (that is, non-scribal), Akkadian-speaking<sup>10</sup> surveyors were active, perhaps only in central Iraq and not in the Sumerian south; alternatively, such a lay group grew out during the next few centuries from the teaching of surveyor-scribes in the Sumerian school. In any case, surveyor-apprentices or -students were trained not only in area calculation but also in “reverse area calculation” – that is, in finding one side of a rectangle from the other side and the area (a problem that would never present itself in surveying practice but probably served to train the metrological system – think of solving the problem if the area is expressed in acres and the known side in yards, feet, inches and lines). After a period (the 21st c. BCE) during which the Sumerian scribe school, the pivot of an extremely centralized economy, had taught only the practically necessary in mathematics, leaving once again no traces

---

<sup>6</sup> Not textbooks for but reflecting the teaching in the *abacus school*, a school mainly for merchants’ and artisans’ sons of age c. 11–12 years.

<sup>7</sup> Thus according to the examples in *Oxford English Dictionary* and the *Grand Larousse*. Only German *Forschung/forschen* begin approaching the modern concept of systematic search for knowledge about a specific field with Goethe and the Romantic movement (according to the *Deutsches Wörterbuch* of the Grimm brothers).

<sup>8</sup> Once more, [Høytrup 2009] may serve as a basic reference.

<sup>9</sup> I follow the “middle chronology”.

<sup>10</sup> Sumerian was the dominant language in the south, Akkadian (a Semitic language later represented by the Babylonian and Assyrian dialects) was spoken in the centre and the north but was also present in the south around 2500 BCE.

of mathematics teaching beyond “model documents”, the “Old Babylonian”<sup>11</sup> scribal school looked for ways to express scribal identity. As far as mathematics is concerned, it drew for this purpose mainly on the riddles of lay practitioners, in particular (but not exclusively) those of the Akkadian-speaking surveyors.

Already around 2200 BCE, as we have seen, the surveyors solved supra-utilitarian problems about a rectangle where the area is known together with the length or the width. At some moment between 2200 and 1800 BCE a trick had been discovered that allows to solve two apparently similar but actually quite different problems: namely to find the sides from the area and the sum of or the difference between the sides. The diagram shows how the latter case is solved by means of a quadratic completion: We know the area to be 60, while the excess of the length over the width is 4. We bisect the excess of the length over the width, and move the outer part around so as to produce a gnomon, still obviously with area 60. The missing small square has the side 2 and thus the area 4; joining this to the gnomon, we get a large square with area 64 and hence side 8. Moving the part that was moved back into its original position we find the width to be  $8-2 = 6$ , and the length to be  $8+2 = 10$ . The method for known sum is different but similar.

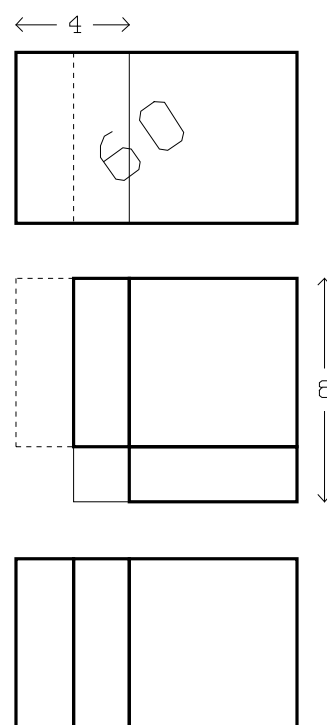

Among the lay surveyors a small set of riddles circulated that could be solved by means of this trick. Later sources allow us to identify them and sometimes even allow us to know the numerical parameters. The original set seems to have encompassed the following problems about squares and rectangles:

$$s + \square(s) = 110$$

$${}_4s + \square(s) = 140$$

$$\square(s) - s = 90$$

$$\square(s) - {}_4s = 60 (?)$$

$$\ell + w = \alpha, \quad \square(\ell, w) = \beta$$

$$\ell - w = \alpha, \quad \square(\ell, w) = \beta$$

<sup>11</sup>Technically, “Old Babylonian” designates the period 2000–1600 BCE; socially and culturally, however, the first century or so was an age of transition; the characteristic Old Babylonian socio-cultural complex only stands out from around 1850.

$$\begin{aligned} \ell + w &= \alpha, & (\ell - w) + \square(\ell, w) &= \beta \\ \ell - w &= \alpha, & (\ell + w) + \square(\ell, w) &= \beta; \\ d &= \alpha, & \square(\ell, w) &= \beta. \end{aligned}$$

Here,  $s$  stands for the side of a square,  $4s$  for “all 4 sides”,  $\square(s)$  for the area, and  $d$  finally for the diagonal;  $\square(\ell, w)$  stands for the area of a rectangle with sides  $\ell$  and  $w$ ; the solution of the diagonal problem presupposes familiarity with the “Pythagorean rule”, which can also be derived by means of cut-and-paste manipulations.

Beyond these, there were problems about two squares (sum of or difference between the sides given together with the sum of or difference between the areas); a problem in which the sum of the perimeter, the diameter and the area of a circle is given, and *possibly* the problem  $d - s = 4$  concerning a square, with the pseudo-solution  $s = 10$ ,  $d = 14$ . That was probably all.

The first thing to happen when these riddles were adopted by the school was an extension to questions about more complex geometrical configurations like subdivided trapezia that could be reduced to one of the standard problems about rectangles or squares. This appears to have happened in Eshnunna, a region to the north-east of Babylon shortly after 1800 BCE. This extension already asked for the generalization of a trick so far only used for the circle problem, a change of scale in one dimension which transforms a problem  $\alpha \cdot \square(s) + \beta s = \gamma$  into a problem  $\square(\alpha s) + \beta \cdot (\alpha s) = \alpha \gamma$ , that is, a familiar problem type, only dealing with a square with side  $\alpha s$  instead of  $s$ . In technical mathematical terms, the operation is a normalization, which allows the treatment of problems with general coefficients.<sup>12</sup>

When Eshnunna was conquered and destroyed by Hammurabi around 1760 BCE, the tradition moved to the south, where the old scribal tradition was stronger; here, it was discovered and exploited that it was possible to formulate problems dealing with other entities familiar from scribal practice whose structure could be *represented* by square or rectangular areas and their sides. So, we find problems about manpower, brick production, prices, or pairs of numbers from the table of reciprocals – all of them, as closer inspection shows, far away from

---

<sup>12</sup> We notice that the surveyors’ riddles involve no (or, termed differently, only “natural”) coefficients: *the* area, *the* side of *all four* sides, etc. Nothing like  $2/3$  of a square area and  $1/3$  of the side. This characteristic, we may say, fits their riddle character – a riddle should be puzzling because it is difficult to see how to answer it, but its formulation should be without technicalities.

what would be encountered in real scribal practice, and thus supra-utilitarian.

We also find problems that extrapolate the problem about the sum of a square area and its side, namely to a problem about the sum of a cubic volume and its base, and other similar cubic problems. These, the school teachers will have discovered, could not be solved by the methods at hand.<sup>13</sup> They were able to develop methods that worked, however, (though only on the condition that a nice integer solution exists, which means that these methods could serve for nothing outside the realm of school problems): use of a table  $n \cdot n \cdot (n+1)$ , and factorization.

In the late 17th century BCE, at least one school also engaged in an endeavour of large-scale systematization.

And then, in 1595, a Hittite raid resulted in the collapse of the Old Babylonian statal and social system, already weakened by a variety of difficulties. The Old Babylonian school disappeared, and so did the kind of mathematics it had created. Lay mensurational practice survived, however; even its riddles survived, and in later times they were adopted anew by environments that could use them in new ways.

## **Proof**

One such environment was that of Greek “philosophical mathematics”, within which we encounter them in another important role. But first some general background.

The first proposed answer to the initial question “what is mathematics” was approximately “Euclid and what he is supposed to stand for – that is, exact proof”.

Euclid no doubt was Greek, or at least writing in Greek during the early Hellenistic period. But did proof begin with the Greeks?

The answer, as mostly, depends on a conceptual delimitation (more or less what Euclid himself did when borrowing from earlier writers the “definition” of a line as “a length without breadth”). At least the Greeks were not the first to use arguments when teaching mathematics. They may, however, have been the first to make mathematical argument an endeavour on its own.

Let us return to the Old Babylonian school. In a way the pertinence of the

---

<sup>13</sup> Actually they almost can; Cardano’s way to solve the general cubic equation combines tricks that are all found in Old Babylonian mathematics. But nobody before him made the combination, and that they *can* be combined in this way is only obvious when they are translated into algebraic symbolism.

above cut-and-paste manipulations is in no need of proof, it is “obvious” that they lead to the result – just as we feel no need for proof when manipulating an algebraic equation (for simplicity excluding negative numbers):

$$\begin{aligned}
 x^2 + 1 \cdot x = \frac{3}{4} &\Leftrightarrow x^2 + 1 \cdot x + \left(\frac{1}{2}\right)^2 = \frac{3}{4} + \left(\frac{1}{2}\right)^2 \\
 &\Leftrightarrow x^2 + 1 \cdot x + \left(\frac{1}{2}\right)^2 = \frac{3}{4} + \frac{1}{4} = 1 \\
 &\Leftrightarrow \left(x + \frac{1}{2}\right)^2 = 1 \\
 &\Leftrightarrow x + \frac{1}{2} = \sqrt{1} = 1 \\
 &\Leftrightarrow x = 1 - \frac{1}{2} = \frac{1}{2} .
 \end{aligned}$$

Even here we “see” naively that what is done must be correct.

Already in the 1930s, before the geometric basis for the Babylonian procedures was understood and when the solutions seemed to consist of nothing but a sequence of unexplained numerical operations, Otto Neugebauer pointed out that the actual teaching would have involved explanations and understanding of why the procedures worked – many of them are far too complicated to have been found by trial and error or to have been communicated meaningfully by rote learning. Since then, some texts have been found that confirm this – they do not solve problems but explain what goes on in the procedure.

One example looks at how the “rectangle equation” “length+width+area = 1” is transformed – see the diagram. Already in the beginning the values of the length and the width are stated – clearly, no problem is to be solved. Then it is explained that the length and the width are prolonged by 1, which produces two extra rectangles, with areas respectively equal to the width and to the length; the sum of the shaded areas is thus 1. The new rectangles contain an empty square of area  $1 \times 1 = 1$ ; when this square is added, the total area will be 2. Next it is shown that the rectangle contained by the prolonged length  $1\frac{1}{2}$  and the prolonged width  $1\frac{1}{3}$  is indeed 2. No strict proof, of course, but a pedagogical explanation which allows the student to understand *why* things work.

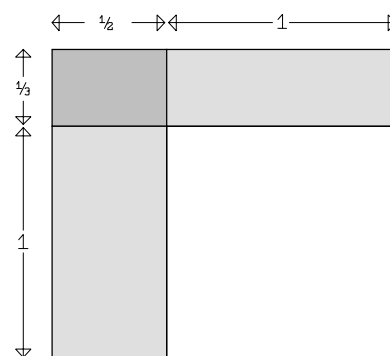

Such pedagogical explanations are not all, however; on several points, the Old Babylonian teachers can be seen to have engaged in *critique* in the Kantian sense – asking in which sense and under which conditions what they did was

valid. What we have just seen is an example of this. The surveyors' riddles had been based on a notion of "broad lines", lines carrying a virtual width of one length unit; some early school problems do the same. Soon, however, some school masters found that unsatisfactory, and they introduced the trick of replacing the lines by rectangles with an explicit width 1. Since this width is termed in no less than three different ways in the corpus, we may presume the device to have been invented several times.

Another example can be seen in the above solution of the problem in which the area of a rectangle is given together with the difference between the sides. Here, early specimens tend to make the final step with the words "join and tear out", and to state the two results immediately afterwards; the Babylonians, as we, would indeed speak of addition before subtraction if nothing prevented it. Here, however, some schoolmasters must have discovered a difficulty; it is in principle impossible to join the piece that is moved back into its original position before it is at disposal, that is, before it has been torn out. They therefore would first tear out, and next, in a separate step, join (as I did above).

However, critique was even less of a systematic effort than the search for new applications and new methods; it was apparently an occasional spin-off from didactical explanation, felt to be necessary by teachers who taught mathematics professionally.

We have no sources for going into similar details concerning the other early written mathematical tradition – that of second-millennium Pharaonic mathematics; even here, however, there are traces of oral explanations, and many of the procedures we find are too complicated to have been transmitted without explanations, and certainly too sophisticated to have been found without understanding. Explicit proof was almost certainly absent; whether the canon that did not allow repetition in the writing of sums of aliquot fractions<sup>14</sup> is a matter of conjecture – my personal feeling is that aesthetics, not critique was involved, but this *is* a feeling and nothing more.

What we know about ancient Chinese mathematics concerns a much later date – even the bamboo strip books found during the latest decades postdate Euclid. Here too, however, there is no doubt that explanations must have been given, even though we do not know possess any in writing earlier than Liu Hui's mid-third century CE commentary to the *Nine Chapters about Mathematical Procedures*. One feature of this commentary is noteworthy in the present

---

<sup>14</sup> For example, the outcome of the division  $2 \div 5$  had to be written  $\frac{1}{3} \frac{1}{15}$ ,  $\frac{1}{5} \frac{1}{5}$  being ostracized although a couple of writing errors indicate that the idea was familiar.

connection, and distinguishes it from anything we find in Mesopotamian or (trace-wise) in Pharaonic mathematics. Mesopotamian and Pharaonic explanations (as well as those of Euclid) keep strictly within the domain of mathematics. Even Plato and Aristotle use mathematics to illustrate philosophical points, but they do not explain what mathematicians do or should do from philosophy.<sup>15</sup>

Liu Hui's commentary is (partially) different. As has been pointed out by Karine Chemla [1997], Liu Hui, when commenting upon algorithms that stepwise transform the givens of a question, applies the language which the *Book of Changes* (*Yijing*) uses for describing real-world transformations. We find something similar in the commentaries in one of the 12th-century Latin versions of the *Elements*, and in that case the obvious reason is that those who made it and those for whom it was made were steeped in the whole of philosophy and not professionally specializing in mathematics. We know nothing about the life of Liu Hui, but we may legitimately expect something similar – indeed, those Chinese high officials who were responsible for taxation, manpower planning, public works, etc. – that is, those who were studying the *Nine Chapters* – were all literary scholars: that was the only way to *become* an official.

Let us now turn to classical Greece, where mathematical argument – probably for the first time in history – emancipated itself from its subservience to teaching, and somehow became a distinctive characteristic of the μαθηματικά, paradoxically “the matters to be taught” *par excellence*.

Some 250 years after his times, Thales of Miletos was supposed to have introduced the “theory” (θεωρία) of geometry to Greece from Egypt, and for instance to have proved that a circle is bisected by a diameter.<sup>16</sup> The historical truth in the claim is uncertain at best, but it calls for two observations. Firstly, what is attributed to Thales is *proof*, not discovery. Secondly, his geometry is supposed to be *theory*, something to *be contemplated*, not something to be used professionally. This is the image Greek philosophers had of the emergence of geometry around 300 BCE, but it also agrees with the general emergence of Greek philosophy in the sixth and fifth century with its questions for causes and for the nature of things. Sixth- and fifth-century natural philosophy, however, was

---

<sup>15</sup> Plato tries (for instance, *Republic* 527A–B, and onward), but he does it in terms so general that they do not prescribe what mathematicians should *do*, nor why something is true or false.

<sup>16</sup> The information comes from Proclus' commentary to *Elements* I [ed. Friedlein 1873: 65, 157] from the late fifth century CE, but on these points Proclus builds on Aristotle's pupil Eudemos.

very different from that of Aristotle; already by analogy (but not only for that reason) we should not expect the “theory” and “proofs” of early geometry to be too similar to what we know from the century of Euclid and Archimedes.

We know that in the later fifth century BCE the problem of incommensurability had already been discovered – there are discordant hypotheses about how it happened, but at least for Aristotle the paradigmatic example is the ratio between the side and the diagonal of a square. This, of course, is truly a theoretical problem – for any practical purposes, also today, rational approximations are necessary as well as sufficient. From the later fifth century BCE we also have the first surviving piece of mathematical argumentation – Hippocrates of Chios’ investigation of lunules, figures contained by circular arcs, and we know that the same Hippocrates wrote a first collection of *Elements*, probably for his private teaching of youths wishing to learn mathematics as a “liberal” (not lucrative) art. During the same decades we know that the famous “three problems” – squaring the circle, doubling the cube, trisecting the angle – were modish enough for some sophists (living from teaching adequate culture to upper-class youth) to take them up. We also know that what Aristotle refers to as “the so-called Pythagoreans” were interested in some kind of mathematics at the time, mixing it with numerology and their philosophy; details, however, are in the dark (the claims of late ancient Neopythagoreans are notoriously unreliable).

More comes from the writings of Plato and Aristotle. Plato (*Republic 510C*) tells that those engaged in geometry distinguish acute, right and obtuse angles – but these could also be practitioners, not all geometry of the epoch was of cause “liberal”. Aristotle is much richer. He knows the Euclidean definition of a line as a length without breadth (*Topics 143<sup>b</sup>28–29*), so geometers of his time had felt the need to rule out the broad lines; he also knows (*Physics 207<sup>b</sup>29–31<sup>17</sup>*) that geometers do not ask for the infinite but only for the possibility produce a finite straight line as much as they wish, which is Euclid’s second postulate. Moreover, the scientific method prescribed in his *Second analytic* is clearly inspired by the methods of geometry, so at his time the ideal of axiomatization was clearly present. Already Plato seems to have known it, but seeing it as a shortcoming of mathematics that its proofs have to build on unproved foundations.<sup>18</sup>

---

<sup>17</sup> In *Prior Analytics* II, 64<sup>b</sup>34–65<sup>a</sup>9 he more or less predicts the need to introduce the fifth postulate in order to eliminate circular reasoning about parallels, showing thus that it had not been done yet.

<sup>18</sup> Therefore, mathematics is only useful as training of immature minds; true insight comes



However, axiomatization was still an aim, not reality: Aristotle tells (*First Analytics* 64<sup>b</sup>34–65<sup>a</sup>9) about those who prove the sum of the angles of a triangle to be equal to two right angles by means of parallel lines, overlooking that the existence of parallels is proved from the sum of the angles of a triangle (and suggests a way out, namely to introduce a postulate<sup>19</sup>).

A number of highly competent mathematicians (not least Theaitetos, Menaichmos and Eudoxos) collaborated at Plato's Academy (not working there only). They prepared the third-century final construction of the Euclidean axiomatic system – not perfect, and subjected to pointwise criticism of single definitions and postulates throughout antiquity, but never replaced by any alternative (except the redaction which Theon of Alexandria prepared for didactical purposes in the fourth century CE, and perhaps by other analogous undertakings about which we have no information).

Also during the third century BCE, we see a number of more advanced developments – Archimedes's various works, both on mathematical mechanics and on questions involving the infinitesimal method of exhaustion; Euclid's and later Apollonios' work on conic sections; etc. Such advanced work had begun already in the fourth century, before the full construction of an axiomatic system; the outcome will certainly have been deductive, but its deductivity will initially have been "local", building on supposedly well-known foundations. This, and not something like the Euclidean system, may have been what Plato thought (and knew) about when speaking about the deficiencies of mathematical reason.

As an illustration of the relation and difference between Euclidean proofs and the kind of explanations that could be given in a school for practitioners we may look at *Elements* II.6. The words of the proposition may seem opaque:<sup>20</sup>

If a straight line be bisected and a straight line be added to it in a straight line, the rectangle contained by the whole with the added straight line and the added straight line together with the square on the half is equal to the square on the straight line made up of the half and the added straight line.

However, looking at the diagram we recognize the situation. ADKM is a rec-

---

from dialectic, where everything is proved (*Republic* 531D–533C). Aristotle may hint at this failing understanding when pointing out that *all* knowledge built on reason starts from previous knowledge (*First Analytic* 71<sup>a</sup>1–2).

<sup>19</sup> Euclid's famous fifth postulate was meant to do the job, but in fact only does so when combined with a fallacy in prop. I.16.

<sup>20</sup> I use the translation in [Heath 1926: I, 385]. For convenience I also Heath's diagram, which only differs from the one in the critical edition by using Latin letters.

tangle, whose length exceeds the width by AB. Rectangle ACKL is half of the excess rectangle, and equals rectangle HMGF, while LHEG is a completing square. All in all, we have precisely the same configuration as in the Old Babylonian rectangle problem that was described above. Euclid's innovation (apart from the wording of the proposition) is in the proof.

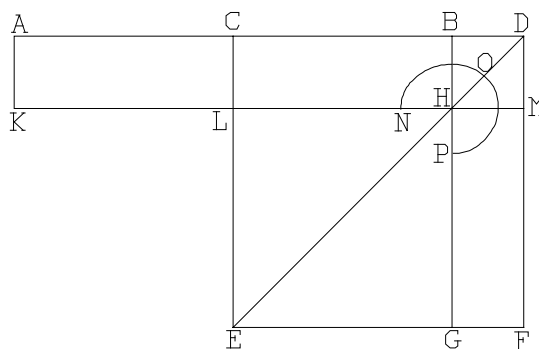

Euclid does not simply cut, move around and paste. He carefully constructs by means of parallels – the diagonal DE then serves to do so in such a way that the rectangles ACKL and HMGF can be proved to be equal. All in all, what Euclid does is to show that what was presupposed “naively” in the Old Babylonian solution can be justified according to the best levels of theory.<sup>21</sup> That is, the proposition in question is an instance of deliberate critique, putting on a firmer base something which was already familiar. This can be stated about the whole sequence II.1–10 – as it turns out [Mueller 1981: 301f], these propositions are practically never used explicitly afterwards, their role is that of critical consolidation of the well-known. Once that was established, they could be tacitly used.

Not everything in Greek mathematics was such critique, far from. Most of what we find in Euclid, Archimedes, Apollonios etc. was not only unknown to the practitioners of earlier cultures, even their questions could not have been imagined. We should not believe, on the other hand, that this high level (or merely the first books of the *Elements*) was standard knowledge at the social level where a “liberal education” was expected. Theon of Smyrna's *Exposition of the Mathematical Topics Useful for Reading Plato* (2nd c. CE) shows us how much knowledge about mathematics could be expected by those who wanted to go on with philosophical studies after having been taught the standard liberal arts – certainly the group from which a maximum could be expected. Theon, as we discover, starts from scratch – and he does not even *arrive* at mathematics with proofs. We find explanations of concepts and of the relations between the branches of mathematics, references to their appearance in general philosophical and literary works, and observations of a numerological character – as the

---

<sup>21</sup> Euclid certainly did not know about what had been done in Babylonia some 1400 years before his time; but we have good evidence that the surveyors' riddles were known in the Mediterranean area during the classical epoch.

twelfth-century commentary to the *Elements* evidence for the general culture and interests of the expected audience. We may think of Liu Hui as a parallel, but Liu Hui knew his mathematics, his philosophy is a supplement. Other handbooks for the liberal arts confirm Theon's picture, but suggest an even lower mathematical level.

Even if we look at Platonizing, Neopythagorean or Neoplatonic philosophers (with the exception of Proclus) we are up for a surprise. When writers like Plutarch or Iamblichos know not only *about* mathematics – about its philosophical status, about its ideological importance – but also some substance, what they know comes not from Euclid or Archimedes but from the techniques of Near Eastern practitioners – see [Høyrup 2000]. Already Hippocrates' work on the lunules and Theodoros's investigation of irrationals, also from the late fifth century BCE, appear to have been beyond their level; but a kind of mathematics was around which they were able to understand. Like the alchemists, they transformed the knowledge of practitioners into “wisdom”.

### **After the Greeks**

The short “golden age” of Greek mathematics ended with the death of Apollonios in the early second century BCE. It was followed by a silver age lasting some seven centuries around the Eastern Mediterranean; neither the golden nor the silver age ever really touched the western part except Magna Graecia. No wonder then that the Early and Central Latin Middle Ages knew no mathematics beyond what could be gained from the liberal-arts handbook tradition (including presumably an epitome of the *Elements* expurgated of proofs); from the Roman agrimensors; from Easter-reckoning; and from what could be made on these foundations. In particular, we find no understanding of what a proof is beyond ad-hoc explanation, not even among those who had gone through a Latin education. But after all, these were administrators, and even if they were nominally taught “liberal arts”, the meaning of this concept had changed into the kind of knowledge fit for those who managed servile labour and were not themselves of servile status.

Even after c. 1100 (that is, during the High and Late Middle Ages), most *vernacular* professional mathematical practice retained this character – also the Italian *abbacus* environment, which sometimes produced quite advanced results. Anthropologically, or in terms of sociology of knowledge, such practice simply continued pre-Greek normality (which, at that level, had never been interrupted, neither in Aristotle's Greece nor in Hellenistic Alexandria).

Among those who got a *Latin* education (at cathedral schools and, as these

emerged, universities), we see some change, at least from the late 12th century onward: some Euclid entered the curriculum, though the philosophical emphasis implied that the interest was often metamathematical rather than mathematical – but that, on the other hand, meant that the notions of proof and axiomatic method (after all, in harmony with Aristotle’s epistemology, which was well studied at universities) came into focus. When university scholars wrote about mathematics that was somehow practical (for example, about how to calculate with Hindu-Arabic numerals, which served in astronomy and astrology, or about the astrolabe), proof had thereby at least become an option; and when an abacus master like Luca Pacioli rose socially to becoming a scholar, he used the option.<sup>22</sup>

In the long run (*very* long), the result was the situation we know today: *even mathematics taught for practice is mostly supposed to build on a safe basis, that is, on deductive proofs* if not necessarily on an axiomatic system. Already in [1728: 867], Friedrich Wolff wrote about “*Mathesis practica*, performing mathematics”, that it is

the kind that performs something, that is, makes use of the understanding it has attained, as when one measures widths and heights by means of similar triangles, and lays out fields in the terrain. It is true that performing mathematics can be learned without reasoning mathematics; but then one remains blind in all affairs, achieves nothing with suitable precision and in the best way, at times it may occur that one does not find one’s way at all. Not to mention that it is easy to forget what one has learned, and that that which one has forgotten is not so easily retrieved, because everything depends only on memory. Therefore all master builders, engineers, calculators, artists and artisans who make use of ruler and compass should have learned sufficient reasons for their doings from theory: this would produce great utility for the human race. Since, the more perfect the theory, the more correct will also every performance be.

This certainly did not by necessity ask for more reasons than what had been given to Babylonian and Pharaonic scribe school students – but Wolff’s last period points forward to the development which we have seen since the creation of the *École Polytechnique* and the *Technische Hochschulen*, gradually spreading in the 20th century to the schooling of humbler professions than civil engineers.

Once practitioners had learned (for instance) elementary algebra, the old recreational riddles became uninteresting – they had become trivial, and could move to the popular press and become truly recreational. But the phenomenon of professional riddles did not disappear (although exam systems had made their

---

<sup>22</sup> The medieval Islamic world offers a similar picture. For reasons of space I shall not pursue the matter.

role less serious and more a personal matter). As I was once told by Eduardo Ortiz, the majority of the subscribers to the *Journal de mathématiques élémentaires*, founded in 1877, were engineers, architects and military officers – the three most important professions that were taught mathematics at a good level. In this journal, they could find lots of problems, not least about triangles, on which to sharpen their teeth (cf. also [Ortiz 1996: 335]).

As schooling was broadened to the whole population during the last centuries, the general tendency was that mathematics in Greek style (really Greek – until well into the 20th century, Euclid or something derived from Euclid mostly served at least as the basis) was the privilege of the elite (felt rather as a heavy burden by many); the “popular classes” were taught their practical mathematics in a way Wolff would not always have approved of. As, officially, the distinction between elite and mass education was abolished after the Second World War, many ways have been tried; the new-math movement tried to base everything on a new kind of demonstrated mathematics (*à bas Euclide, plus de triangles*, in Dieudonné’s famous words). As transformation groups and Bourbaki proved failures at school level, various other ways were tried – sometimes “back to basics” (mere training of arithmetic), often reasoning not too different in style (certainly in contents) from what we see reflected in the Old Babylonian texts.

Mathematics, taught in an organized way beyond the simplest matters, is essentially based on argument. But the axiomatically secured foundation, once the *sine qua non* for the discoveries of Archimedes and Apollonios but not adopted by those of their contemporaries who made city planning, built aqueducts or measured land, also today is often needed for the expansion of advanced mathematical knowledge – yet apparently not for everyday uses of the discoveries and knowledge of the day before yesterday.

## References

- Ascher, Marcia, & Robert Ascher, 1986. “Ethnomathematics”. *History of Science* **24**, 125–144.
- Chemla, Karine, 1997. “Croisements entre pensée du changement dans le *Yijing* et pratiques mathématiques en Chine ancienne”, pp. 191–205 in J. Gernet & M. Kalinowski (eds), *En suivant la voie royale. Mélanges en l’honneur de L. Vandermeersch*. Paris: Presses de l’École Française d’Extrême-Orient.
- D’Altroy, Terence N., 2015. *The Incas*. Second edition. Malden, Mass., & Oxford: Wiley-Blackwell.
- D’Ambrosio, Ubiratan, 1987. *Etnomatematica. Raizes Socio-Culturais da Arte ou Tecnica de Explicar e Conhecer*. Campinas.
- Folkerts, Menso (ed.), 1978. “Die älteste mathematische Aufgabensammlung in lateinischer Sprache: Die Alkuin zugeschriebenen *Propositiones ad acuendos iuvenes*”. *Österreichische*

- Akademie der Wissenschaften, Mathematisch-Naturwissenschaftliche Klasse. Denkschriften*, 116. Band, 6. Abhandlung (Wien).
- Friedlein, Gottfried (ed.), 1873. *Procli Diadochi In primum Euclidis Elementorum librum commentarii*. Leipzig: Teubner.
- Gerdes, Paulus, 1997. *Ethnomathematik – dargestellt am Beispiel der Sona Geometrie*. Heidelberg etc.: Spektrum Akademischer Verlag.
- Goody, Jack, 1987. *The Interface between the Oral and the Written*. Cambridge: Cambridge University Press.
- Heath, Thomas L. (ed., trans.), 1926. *The Thirteen Books of Euclid's Elements*, Translated with Introduction and Commentary. 2nd revised edition. 3 vols. Cambridge: Cambridge University Press / New York: Macmillan.
- Høyrup, Jens, 1994. *In Measure, Number, and Weight. Studies in Mathematics and Culture*. New York: State University of New York Press.
- Høyrup, Jens, 2001. "Alchemy and Mathematics. Technical Knowledge Subservient to Ancient  $\gamma\omega\sigma\iota\varsigma$ ", pp. 38–54 in Vincent F. Hendricks & Jesper Ryberg (eds), *Readings in Philosophy and Science Studies*, vol. I. Roskilde: Department of Philosophy and Science Studies, 2001. Marred by numerous computer conversion errors, undiscovered because of the omission of author's proof reading. A preprint version free of these can be found at  
[http://www.akira.ruc.dk/~jensh/Publications/2000%7Bd%7D\\_Alchemy.PDF](http://www.akira.ruc.dk/~jensh/Publications/2000%7Bd%7D_Alchemy.PDF)
- Høyrup, Jens, 2009. "State, 'Justice', Scribal Culture and Mathematics in Ancient Mesopotamia." *Sartonia* 22, 13–45.
- Mueller, Ian, 1981. *Philosophy of Mathematics and Deductive Structure in Euclid's Elements*. Cambridge, Mass., & London: MIT Press.
- Ong, Walter J., 1977. *Interfaces of the Word: Studies in the Evolution of Consciousness and Culture*. Ithaca, New York, & London: Cornell University Press.
- Ong, Walter J., 1982. *Orality and Literacy. The Technologizing of the Word*. London & New York: Methuen.
- Ortiz, Eduardo, 1996. "The Nineteenth-Century International Community and its Connection with Those on the Iberian Periphery", pp. 321–343 in Catherine Goldstein, Jeremy Gray & Jim Ritter (eds), *L'Europe mathématique. Mathematical Europe*. Paris: Éditions de la Maison des sciences de l'homme.
- Scriba, Christoph J., 1992. "Historiographie der Mathematik als Wissenschaft, Kunst – und Macht?" *Archives Internationales d'Histoire des Sciences* 42, 10–26.
- Tropfke, J./Vogel, Kurt, et al, 1980. *Geschichte der Elementarmathematik*. 4. Auflage. Band 1: *Arithmetik und Algebra*. Vollständig neu bearbeitet von Kurt Vogel, Karin Reich, Helmuth Gericke. Berlin & New York: W. de Gruyter.
- Wolff, Christian, 1716. *Mathematisches Lexicon*. Leipzig: Joh. Friedrich Gleditschens seel. Sohn.