

## **Predicting impacts of oil spills - Can ecological science cope?**

A case study concerning birds in Environmental Impact Assessments

Mosbech, Anders

*Publication date:*  
2000

*Citation for published version (APA):*

Mosbech, A. (2000). *Predicting impacts of oil spills - Can ecological science cope? A case study concerning birds in Environmental Impact Assessments*. Roskilde Universitet.

### **General rights**

Copyright and moral rights for the publications made accessible in the public portal are retained by the authors and/or other copyright owners and it is a condition of accessing publications that users recognise and abide by the legal requirements associated with these rights.

- Users may download and print one copy of any publication from the public portal for the purpose of private study or research.
- You may not further distribute the material or use it for any profit-making activity or commercial gain.
- You may freely distribute the URL identifying the publication in the public portal.

### **Take down policy**

If you believe that this document breaches copyright please contact [rucforsk@kb.dk](mailto:rucforsk@kb.dk) providing details, and we will remove access to the work immediately and investigate your claim.



Ministry of Environment and Energy  
National Environmental Research Institute

# Predicting impacts of oil spills - Can ecological science cope?

A case study concerning birds in Environmental  
Impact Assessments

*PhD Thesis*  
*Anders Mosbech*

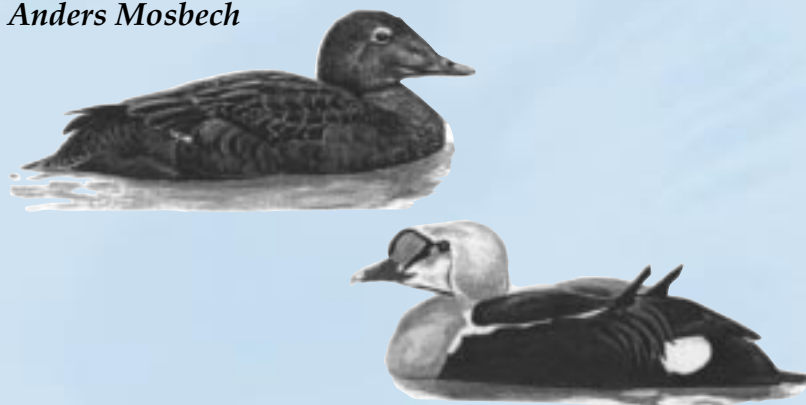

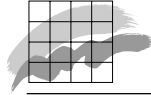

Ministry of Environment and Energy  
National Environmental Research Institute

---

# Predicting impacts of oil spills - Can ecological science cope?

A case study concerning birds in Environmental Impact Assessments

*PhD Thesis*

*Anders Mosbech*

Department of Arctic Environment

## Data sheet

Title: Predicting Impacts of Oil Spills – Can Ecological Science Cope ?  
Subtitle: A case study concerning birds in Environmental Impact Assessments  
Author: Anders Mosbech

Department: Department of Arctic Environment

Publisher: Ministry of Environment and Energy  
National Environmental Research Institute

URL: <http://www.dmu.dk>

Date of publication: October 2000

Please cite as: Mosbech A. (2000): Predicting Impacts of Oil Spills – Can Ecological Science Cope ?  
A case study concerning birds in Environmental Impact Assessments. National  
Environmental Research Institute, Denmark. 126 pp.

Reproduction is permitted, provided the source is explicitly acknowledged.

Abstract: It is analysed, how the potential impact of large oil spills on seabird populations are dealt with in the strategic environmental impact assessments (EIA) of oil exploration in the Barents Sea (1988) and the Beaufort Sea (1996). Current knowledge on the effect of large oil spills on bird populations is reviewed as background information for the analysis. The analysis of the two EIA cases focus on what ecological science can deliver to the EIA process and how the EIAs can manage with what they get. The use of oil spill scenarios and impact indices in the EIA-reports is discussed.

Keywords: seabirds, oil spill, environmental impact assessment, EIA, ecology

Financial support: Danish Research Academy

ISBN: 87-7772-566-2

Paper quality and print: Cyclus Office, 100 % recycled paper. Grønager's Grafisk Produktion AS.  
This publication has been marked with the Nordic environmental logo "Svanen".



Number of pages: 126  
Circulation: 150

Price: DKK 100,- (incl. 25% VAT, excl. freight)

Internet-version: The report is also available as PDF-file from NERI's homepage

Authors E-mail: [amo@dmu.dk](mailto:amo@dmu.dk)

For sale at:

National Environmental Research Institute PO Box 358 Frederiksborgvej 399 DK-4000 Roskilde Denmark Tel.: +45 46 30 12 00 Fax.: +45 46 30 12 00	Miljøbutikken Information and Books Læderstræde 1 DK-1201 Copenhagen K Denmark Tel.: +45 33 95 40 00 Fax: +45 33 92 76 90 e-mail: <a href="mailto:butik@mem.dk">butik@mem.dk</a> <a href="http://www.mem.dk/butik">www.mem.dk/butik</a>
--	---

# Contents

<b>Abstract</b>	<b>1</b>
<b>Sammenfatning</b>	<b>2</b>
<b>Preface</b>	<b>9</b>
<b>1 Introduction</b>	<b>12</b>
1.1 Background of the study	12
1.2 Outline and thesis	13
<b>2 The EIA concept and the use of ecological science</b>	<b>14</b>
2.1 History and definition	14
2.2 The contents of an EIA	16
2.3 EIA-methods	17
2.4 Focusing ecological research in EIA	21
2.5 Ecological impact studies	24
2.6 Modelling	27
2.7 Recent developments in ecology	28
<b>3 The impact of marine oil spills on bird populations</b>	<b>30</b>
3.1 The effect of oil on seabirds	30
3.2 Predicting population impacts of oil spills with simulation models	35
3.3 Evidence of population impacts after oil spills	37
3.4 Discussion - Prediction of population effects	41
3.5 Methods in the comparative case study of EIAs	42
<b>4 The Barents Sea Case</b>	<b>47</b>
4.1 Ecological presentation	47
4.2 The EIA document	52

4.3	The oil/bird background reports	56
4.4	The fate of the EIA-report	62
4.5	Conclusion on the Barents Sea EIA of oil and seabirds	65
<b>5</b>	<b>The Beaufort Sea Case</b>	<b>67</b>
5.1	Ecological presentation	67
5.2	The EIA document	71
5.3	Beaufort Sea bird data in the assessment	74
5.4	Assessing the effects of oil spill on marine and coastal birds	75
5.5	The case of the spectacled eider - an undetected risk	78
5.6	Other Comments to the Draft and Final EIS	79
5.7	The National Research Council information assessment	81
5.8	Conclusion on the Beaufort Sea EIS for seabirds	84
<b>6</b>	<b>Discussion</b>	<b>86</b>
6.1	The internal scientific perspective	86
6.2	The broad policy perspective	93
6.3	Conclusion	97
<b>7</b>	<b>References</b>	<b>99</b>
<b>8</b>	<b>Appendices</b>	<b>114</b>
	Appendix 1: Scientific, British, US English and Danish list of animal species mentioned in the text, and an acronym glossary	115
	Appendix 2: The seabird example from the MUPS system	117
	Appendix 3: The EIA procedure and schedule for the Beaufort Sea leasing process	122

# Abstract

It is analysed, how the potential impact of large oil spills on seabird populations are dealt with in the strategic environmental impact assessments (EIA) of oil exploration in the Barents Sea (1988) and the Beaufort Sea (1996). Current knowledge on the effect of large oil spills on bird populations is reviewed as background information for the analysis. The analysis of the two EIA cases focus on what ecological science can deliver to the EIA process and how the EIAs can manage with what they get.

It is concluded that scientific knowledge is generally not adequate to make quantitative predictions of the impact of a large oil spill on bird populations. The immediate mortality can only be crudely estimated, and the restitution of the population can only be assessed in very broad terms with considerable uncertainty. For many populations, there are lacks of understanding of the capacity for resilience, of natural fluctuations, and of the effect of other human impacts. Experiences with impacts from actual spills are important in the assessments because of lack of scientific understanding of the population dynamics.

The most vulnerable areas and periods can be identified using relative assessment methods. The potential effect of a large oil spill can be minimised by planning (unavoidable) risky activities so the most important areas and periods are avoided. The potential effect can also be minimised by improving the status for populations (subpopulations and colonies) which face the risk of serious impacts, if a large oil spill occurs.

The use of oil spill scenarios and impact indices in the EIA-reports is discussed. In addition, the use of scenarios and indices is related to the facilitation of discussions of accept criteria for potential effects and the uncertainty involved.

# Sammenfatning

## Kan man forudsige effekter på fuglebestande af et stort oliespild ?

### Et studie af havfugle, økologi og miljøkonsekvensvurderinger af oliespild i Arktis

I denne rapport undersøges hvilke muligheder og begrænsninger, der er for at give videnskabeligt baserede forudsigelser af de mulige effekter på havfuglebestande af et stort marint oliespild i Arktis. Spørgsmålet behandles med henblik på at vurderinger af mulige effekter kan indgå konstruktivt i en miljøkonsekvensvurderings- og beslutningsproces om olieudvindingsaktiviteter. Spørgsmålet er belyst dels ved at undersøge cases fra miljøkonsekvensvurderinger i Barentshavet og Beauforthavet, dels gennem et review af effekter af oliespild på havfugle. Desuden anskues spørgsmålet i en bredere sammenhæng som et eksempel, der kan bidrage til belysning af hvordan økologisk videnskab mere generelt fungerer i samspil med miljøkonsekvensvurderinger, når der skal tages højde for væsentlig usikkerhed og mangel på viden i de økologiske vurderinger.

### Forudsigelse af effekter - teori og erfaring

Grundlaget for en miljøkonsekvensvurdering er at man kan beskrive de mulige konsekvenser af de aktiviteter der skal tages politisk stilling til. Et stort oliespild er den største miljørisiko ved at starte olieeftersforskning i Arktis. Det er imidlertid usikkert at forudsige effekterne af et stort oliespild, fordi det afhænger meget af omstændighederne, og der er et lille erfaringsmateriale. Vurderingerne må derfor basere sig på teoretiske overvejelser over hvor udsatte bestandene er og hvad deres potentiale for at komme sig er. De teoretiske overvejelser kan så suppleres med erfaringer fra spild i tempererede egne, og evt. bestandenes reaktion på jagt eller tilfælde af naturlig massedød. Disse analyser, hvor erfaringer fra et område skal overføres til andet, er imidlertid hæmmet af mangel på forståelse af bestandenes dynamik.

Når der er grund til særlig opmærksomhed ved vurdering af olieaktiviteter i arktiske områder skyldes det at en række tekniske og økologiske forhold potentielt gør effekterne af et oliespild værre i arktiske end i tempererede egne.



Det er meget vanskeligt at bekæmpe et oliespild i isfyldt farvand, og olie er længere tid om at omdannes og nedbrydes i koldt vand. Et oliespild vil derfor, alt andet lige, i længere tid ligge på havoverfladen og udgøre en risiko for fuglenes fjerdragt. Samtidig kan vinden presse spildt olie sammen ved iskanter, hvor der i perioder kan forekomme store fuglekoncentrationer. Det kolde vand øger også skadevirkningen af olie på fjerdragten idet skaden ved tab af fjerens isolerende evne er væsentlig større i koldt vand. Disse forhold kan også være tilstede om vinteren i tempererede egne, men er mere udtalte og gælder også for yngletiden i store dele af det arktiske område. Desuden er der i Arktis en tendens til at ynglebestande af flere vigtige arter er koncentreret i relativt få store kolonier, og de er dermed mere sårbare overfor olieforurening.

Givet at der sker et stort oliespild er der tre væsentlige elementer i en forudsigelse af effekterne på en fuglebestand. (1) Der er først og fremmest sandsynligheden for et sammenfald i tid og sted af fugle og olie. (2) Så er der sandsynligheden for at de fugle der forekommer samme sted som oliespildet dør eller bliver væsentligt påvirket på anden måde. (3) Og endelig er der bestandens reaktion på en masse mortalitet. For at give en pålidelig forudsigelse er det nødvendigt med et godt kendskab til alle tre elementer.

Der kan med nogen sikkerhed laves statistiske beregninger på sandsynligheden for oliens spredning på havoverfladen i forskellige områder (under en række forudsætninger om spildsted, olietype osv.).

Sandsynligheden for en masse mortalitet afhænger udover oliens spredning, af hvor lang tid den enkelte fugl tilbringer på havoverfladen, i hvor stort et område fuglen færdes og hvor store dele af bestanden der er koncentreret i områder, der i størrelse svarer til hvad et enkelt oliespild kan påvirke. Usikkerheden i disse vurderinger går bl.a. på om fuglene vil forsøge at undgå et oliespild på havoverfladen, samt vurderinger af fuglenes fordeling.

Bedømmelse af fuglenes fordeling i tid og sted kan i mange tilfælde ske ret præcist når man har kortlagt fuglekolonier, trækruter og vigtige raste og fældeområder. I kystområder kan der ofte nås en stor forudsigelighed i fuglenes forekomst, selvom der kan være variationer fra år til år der især skyldes vejrforholdene. Offshore er forekomsterne typisk mere variable både fra år til år, og fra uge til uge. Vi kender ikke nok til den dynamik der bestemmer fødeemnernes varierende pelagiske fordeling, ligesom storme kan give væsentlige omfordelinger af fugleforekomster på det åbne hav. Ofte må man i forhold til pelagiske forekomster i offshore områder nøjes med at afgrænse større områder indenfor hvilke der hyppigt optræder store koncentrationer.

Der er imidlertid ingen tvivl om at et stort oliespild for mange arter kan føre til en stor dødelighed. Det bekræfter også erfaringer med oliespild, der i øvrigt viser at selv små oliespild på "det forkerte tid og sted" kan medføre stor dødelighed.

Fuglepopulationers robusthed overfor en masse mortalitet er et vanskeligt spørgsmål at vurdere. Der eksisterer ikke en generel teori for fugles populationsdynamik, der kan benyttes til at besvare spørgsmålet. Der findes dog en række populationsdynamiske undersøgelser af fuglebestande, og der er udviklet flere hypoteser for bestandenes regulering. Derudover kan der trækkes på erfaringer med masse mortalitet fra oliespild, jagt og naturlige katastrofer.

Baseret på cases fra Barentshavet og Beauforthavet, erfaringer fra undersøgelser af Exxon Valdez og andre oliespild, samt erfaringer fra arbejdet i Vestgrønland konkluderes det at den videnskabelige forståelse generelt ikke er tilstrækkelig til at forudsige effekterne af et stort oliespild (publikation 8). De umiddelbare konsekvenser i form af mortalitet kan modelleres om end med stor usikkerhed, men bestandenes udvikling/restitution kan kun skønnes i meget brede vendinger, fordi der er en ringe forståelse af dynamikken i de naturlige bestandssvingninger og effekter af andre menneskelige påvirkninger. De konkrete erfaringer med effekterne fra oliespild spiller i disse skøn en væsentlig rolle i forhold til den videnskabelige forståelse af dynamikken i systemerne.

Man kan sige at når det drejer sig om at forudsige sammenfald af fugle og olie er der ofte en usikkerhed der skyldes specifik datamangel til statistisk beskrivelse af fuglenes fordeling og i visse tilfælde uvidenhed om de fordelende faktorer. Når det derimod kommer til at vurdere, hvor robuste bestande er overfor en masse mortalitet, er der både mangel på data og en betydelig uvidenhed om mekanismer. Der eksisterer en række hypoteser om væsentlige faktorer i bestandsreguleringen hos de enkelte arter, men der er en uvidenhed om den relative betydning af mekanismerne, om niveauer hvor der kan indtræde ikke-lineære reaktioner (f.eks. kolonier der forlades) og ofte mangler der data om den specifikke tilstand (bestandsudvikling) af bestande og delbestande. En sådan specifik viden er nødvendigt, for at kunne vurdere en bestands robusthed overfor en masse mortalitet.

### **Indexmetoder, scenarier og den integrerede populationsdynamiske analyse**

Da det er det svageste led i kæden der bestemmer niveauet for usikkerheden på forudsigelser af effekter, er der et betydeligt problem i at give forudsigelser af effekter af oliespild i

miljøkonsekvensanalyser. Der er ikke desto mindre et behov for at formidle den viden der faktisk eksisterer med den usikkerhed der er, samt at identificere muligheder for at forbedre forudsigelserne for de konkrete projekter.

Desuden er det af betydelig værdi at påpege metoder til at minimere de mulige effekter af olieaktiviteterne. Det er vigtigt at få identificeret vigtige og sårbare områder og perioder, således at risikoen for disse kan begrænses ved planlægning og regulering af aktiviteterne. Vigtige og sårbare områder kan identificeres ved hjælp af relative metoder, hvor der ikke behøves samme niveau af viden som ved forudsigelser af effekter.

Beskrivelsen af de mulige miljøkonsekvenser blev behandlet forskelligt i Barentshavet og i Beauforthavet. I miljøvurderingen fra Barentshavet afstod man fra at give andet end relative og kvalitative vurderinger af de mulige effekter på grund af den betydelige usikkerhed. I miljøvurderingen fra Beauforthavet blev der givet grove overslag over dødelighed og varighed af effekterne efter oliespild.

I miljøvurderingen fra Barentshavet var der udregnet index værdier for relativ sårbarhed der integrerede en lang række vurderinger, mens der i vurderingen fra Beauforthavet blev benyttet en række scenarier med kvantitative beskrivelser af de sandsynlige effekter. Disse metoder har hver især fordele og ulemper. Fælles for dem er at de i en EIA sammenhæng ikke kan stå alene, men højst kan fungere som støtte for expertvurderinger, der må understrege den fragmentariske forståelse der ligger til grund for vurderingerne.

Scenarierne visualiserer de mulige konsekvenser, og er derfor gode til at formidle hvad der kan ske. Det er imidlertid svært i de konkrete scenarier at formidle den faktiske usikkerhed. Index-metoderne har mulighed for at integrere mange forskellige faktorer til enkle sammenlignelige værdier. Det er klart ved dette studie at der ved forskellige varianter af indexmetoder kan foretages rimeligt kvalificerede relative vurderinger af sårbarhed mellem fuglebestande og mellem områder. Index-værdierne er imidlertid meget vanskelige at forholde sig til for udenforstående når det drejer sig om at beslutte hvad der er en acceptabel risiko og har nok her deres største værdi som støtte for professionelle skøn.

I miljøvurderingen fra Vestgrønland (publikation 2 og 3) er der udviklet en forenklet metode til vurdering af bestandenes sårbarhed. Metoden benytter træk fra såvel index-systemet brugt i Barentshavet og scenarie-metoden brugt i Beauforthavet. Der er valgt en enkel metode dels i betragtning af de begrænsede data dels for at gøre vurderingerne så gennemskuelige som muligt.

Hver bestands sårbarhed vurderes efter fem kriterier på en tredelt skala. Kriterierne ganges ikke sammen som et index, men benyttes som udgangspunkt for en kvalitativ vurdering og identifikation af problembestande. For de bestande, hvor der er data til det, forsøges det at lave overslag over dødeligheden i et oliespild-scenarier. For de bestande hvor der kan være væsentlige problemer lægges der op til

integreret management af bestanden. Således forsøges det at se dødeligheden fra et oliespild i forhold jagten, der er den største menneskelige påvirkning af fuglebestande i Grønland.

For på længere sigt at kunne gennemføre mere præcise miljøvurderinger er der behov for at konkrete effekter af olieaktiviteterne vurderes i helhedsanalyser af vigtige bestande, der kan blive væsentligt påvirket. Helhedsanalyser bør udføres for hele bestandens udbredelsesområde (flyway), og inddrage populationsdynamiske parametre, identificere flaskehalse (begrænsende faktorer) og munde ud i forvaltningsplaner, der ser på effekten af de samlede påvirkninger af bestanden (analyser og forvaltningsplaner på bestandsniveau).

Det har således været antaget at arter med lang levetid og lav reproduktionsevne (K-selekterede arter) ville være uhyre sårbare overfor masse mortalitet især af adulte fugle. Det viser sig imidlertid at være en sandhed med modifikationer. Noget kunne tyde på at sådanne bestande kan have mulighed for at have en bufferkapacitet af potentielt ynglende fugle der rykker ind og/eller at især ungfugle fra andre kolonier fordeler sig i kolonier hvor der bedst plads efter en masse mortalitet. Opbygningen af en sådan gruppe af "floaters" i det pelagiske miljø hvor der formodes at være rigeligt med føde (Survival-habitat sensu Alerstam og Høgstedt 1982) hos alkefugle (stærkt K-selekterede og S-arter sensu Alerstam og Høgstedt), kan fungere som en tilpasning til at håndtere masse mortalitet. Overfor enkeltstående tilfælde af oliespild kan denne buffer være lige så effektiv som en hurtig bestandstilvækst hos arter med højt reproduktionspotentiale og kortere levetid (r-selekterede arter). Omvendt kan arter som svømmeænder der formodes at være føde-begrænset i deres vinterkvarter (B-arter sensu Alerstam og Høgstedt) optræde i koncentrationer der gør dem ligeså udsatte for masse mortalitet ved et oliespild (hvis ellers vinterkvarteret er marint) som f.eks. alkefugle kan være det i yngletiden hvor de er koncentreret ved fuglekolonierne. Mens alkefugle om vinteren, når der er rigeligt med føde i det marine miljø, ofte vil findes mere spredt end ved kolonierne.

Det skal understreges, at en evt. bufferkapacitet kun kan forventes hos bestande der ikke er presset af andre faktorer. Hver enkelt bestand bør gøres til genstand for en konkret analyse af dens udsathed og robusthed. En analyse der vurderer det samlede stress på bestanden kan laves efter de tre dimensioner: (1) Det potentielle reproduktionspotentiale (r - K dimension), (2) bestandens bufferkapacitet (B-arter, S-arter dimension) og her vurderes bestandens størrelse og trend i forhold til begrænsende faktorer konkret og (3) en metapopulations-dimension der belyser potentialet for indvandring.



*“ where there are threats of serious or irreversible damage, lack of full scientific certainty shall not be used as a reason for postponing cost effective measures to prevent environmental degradation.”* The precautionary approach as stated in the Rio Declaration (principle 15)

## Preface

This study is part of a Ph.D. thesis on ecological science in the assessment of the impact of oil exploration in the Arctic. The thesis was successfully defended at Roskilde University in May 1999. Minor edition has been done in this report afterwards.

The Ph. D. project consists of three parts: (I) Scientific studies producing basic data on numbers and distribution of seabirds in West Greenland, for the purpose of assessing the impact of oil exploration activities (Boertmann and Mosbech 1997, 1998, Mosbech and Boertmann in 1999, Mosbech and Johnson 1999); (II), impact assessment of offshore oil exploration in West Greenland (Mosbech et al. 1995, Mosbech et al. 1996, Mosbech 1997); and (III) this case study which analyses impact assessments of offshore oil exploration in the Barents Sea and the Beaufort Sea. Furthermore, this case study is used as a platform for a view of the role of science in impact assessments.

There was a striking paucity of ecological data in West Greenland when offshore oil exploration became an issue in the 1990's. In particular information on seabird numbers and distribution was lacking and the National Environmental Research Institute (NERI) initiated a number of studies. During this period we have conducted ornithological studies on numbers and distributions of sea-associated birds mainly focusing on identifying the areas most sensitive to marine oil pollution. Studies often also addressed methodological problems of surveying numbers and distribution due to the behaviour of birds and/or the vast area. Species studied included moulting king eiders (Mosbech and Boertmann 1999) and colonial seabirds like the little auk and great cormorant (Boertmann et al. 1996, Boertmann and Mosbech 1997, 1998). Seabirds were studied at sea during the summer (Mosbech et al. 1998). Spring migration (Mosbech et al. 1996) and winter distribution were analysed as well (Mosbech and Johnson 1999).

I began working with impact assessments of offshore oil activities when I participated in the preparation for oil exploration off West Greenland (Christensen et al. 1993, Mosbech and Dietz 1994). In addition I was involved in an earlier review of marine oil pollution in Denmark (Mosbech 1991). We presented an outline of environmental impact assessment of offshore oil and gas activities in the Arctic (Mosbech et al. 1995). The first assessment of potential environmental impacts of oil exploration during the summer period in an area opened for oil exploration (the Fylla Area) was done in 1996 (Mosbech et al. 1996). A method for assessing seabird vulnerability to oil spills in the eastern Davis Strait was presented at a conference in 1997 (Mosbech 1997). Later all available environmental background information from this area was compiled and assessed (Mosbech et al. 1998) and a popular account was published (Boertmann et al. 1998).

A major point in my approach has been that although EIA by definition deals with the assessment of the impact of a single activity (or project), the total impact of all activities on a populations must be considered, and not just the impact of the activity in question. It has therefore been valuable to participate in the work of the Circumpolar Seabird Working Group (within the Arctic Environmental Protection Strategy), where we have developed circumpolar conservation strategies and action plans for guillemots (murre) and eiders (CAFF 1996, 1997, 1998). The recent development of seabird and marine mammals populations in Greenland, and the potential effects of oil activities, was also put into a broader perspective in a review of the environmental status of the seas around Greenland (Riget et al. 2000).

In this context the present case study has been valuable, both because it deals with two Arctic areas where oil exploration – and impact assessments of oil explorations - are ahead of Greenland. And because West Greenland (the eastern Davis Strait) in some ecological sense (for example ice cover and productivity) is an intermediate between the Beaufort and the Barents Sea. Furthermore, the analyses of these cases from outside, have also facilitated a broader view over the role of science and scientist in EIA's.

The Ph. D. project was conducted at Roskilde University, the Department of Environment, Technology and Social Studies, under the supervision of Professor Peder Agger. The study was initiated in autumn 1995 and conducted as a part-time study during my employment at the National Environmental Research Institute, Department of Arctic Environment. Financial support was received from the Danish Research Academy.

I am grateful to Peder Agger for fruitful discussions and eye-opening introductions to new fields and perspectives and I thank the opponents Tycho Anker-Nilssen, Jesper Madsen and Henning Schroll for constructive comments. Poul Johansen, David Boertmann, and Frank Riget are thanked for comments to an early version of the manuscript. Also I thank Ritta Bitsch for a drawing, Andrew Crabtree for improving the language, Lars Gissing Hansen for providing official Danish names of American species and Jose Nymand, Jørgen Hinkler and Elin Vilner for help with various technical tasks. Finally I would like to thank my wife and children, Lene, Pernille and Frederikke, for their patience.



The following publications are included in the thesis:

1. Mosbech, A., R. Dietz & D. Boertmann 1995: Environmental Impact Assessment of offshore oil exploration, production and transportation in the Arctic, with emphasis on ecological impacts of oil spills. Proceedings of the 14th International Conference on Offshore Mechanics and Arctic Engineering. Vol. IV Arctic/Polar Technology p. 193-201.
2. Mosbech, A., R. Dietz, D. Boertmann & P. Johansen 1996: Oil Exploration in the Fylla Area, An Initial Assessment of Potential Environmental Impacts. National Environmental Research Institute, 92pp. - NERI Technical Report no. 156.
3. Mosbech, A. 1997: Assessment of Seabird Vulnerability to Oil Spills in the Eastern Davis Strait. In: Proceedings from the Fifth International Conference on Effects of Oil on Wildlife. November 3-6, 1997, University of California. pp. 32-49.
4. Boertmann, D. & A. Mosbech 1997. Breeding distribution and abundance of the great cormorant *Phalacrocorax carbo carbo* in Greenland. Polar Research 16 (2): 93-100.
5. Boertmann, D. & A. Mosbech 1998. Distribution of little auk *Alle alle* breeding colonies in Thule District, northwest Greenland. Polar Biology 19: 206-210.
6. Mosbech, A. & D. Boertmann 1999. Distribution, abundance and reaction to aerial surveys of post-breeding king eiders (*Somateria spectabilis*) in western Greenland. Arctic 52 (2): 188-203.
7. Mosbech, A. & S.R. Johnson 1999. Late Winter Distribution and Abundance of Sea-Associated Birds in Southwest Greenland, the Davis Strait, and Southern Baffin Bay. Polar Research 18 (1): 1-17.
8. Mosbech, A. 1999. Predicting impacts of oil spills - Can ecological science cope? A case study concerning birds in Environmental Impact Assessment. (This report).

# 1 Introduction

## 1.1 Background of the study

Environmental impact assessments of major activities which are potentially harmful to the environment are a normal practice in western industrialised countries, although different administrative and political procedures are followed. The aim of such studies is to predict potential environmental damage in a way which allows for some sort of a political overall cost benefit analysis of the activity in question. Furthermore, this process makes it possible to evaluate the way in which to conduct the activity in question with a minimal impact on the environment.

The environmental impact assessment process is a challenge to the ecologist. A thorough understanding of the ecosystem is needed to be able to predict and quantify short term as well as medium and long term impacts of the perturbations which industrial activities may cause. Often only imperfect information is available. This has been especially true for early impact assessments of industrial oil activities in the Arctic. Here a significant lack of knowledge has been revealed of the ecosystem itself, of the sensitivity of the system to oil activities and of human induced perturbations in general. In 1985 the National Research Council in the USA reviewed current knowledge on marine oil pollution and concluded that: "*The potential impact of a major oil spill on an Arctic ecosystem can presently not be estimated with confidence*" (National Research Council 1985).

Since then several strategic EIAs of plans for opening Arctic marine areas for oil activities have been carried out, accompanied by extensive ecological research programmes. The present study focuses on how ecological knowledge of birds is produced and used in two EIA cases of oil activities in the Arctic, the Barents Sea and the Beaufort Sea. Both areas were opened for oil exploration based on an EIA process, which included the option of not opening the areas. I focus on seabirds and oil spills, because a large oil spill is considered the worst potential impact of oil exploration, and seabirds are the group most vulnerable to oil spills. The focus in this study is primarily on seabirds as a valuable resource in themselves. However, seabirds can also be used as indicators of ecological impact at lower trophic levels, as they are relatively easy studied predators in the marine environment (e.g. Monaghan 1996).

My starting point for this project was the experience of a gap between on the one hand, the need for firm assessments of the potential impact of an oil spill in Greenland, and on the other hand, imperfect data and lack of understanding of the Arctic ecosystem function. The Beaufort Sea and The Barents Sea were further developed in relation to oil exploration than Greenland, and large EIAs had been carried out in these areas. I therefore turned to these areas to study how the EIAs were handled and how the ecological scientific bases for the assessments were developed. The study focus

on bird populations, as the group most vulnerable to oil spills, and the general knowledge on the impact of marine oil spills on bird populations is reviewed. During the study it appeared that very important knowledge has been learned from the studies of actual spill events. Results from actual impact studies challenged the (theoretically based) predictions of potential impacts.

In this report I focus on the use of ecological science in EIA. In a sense one has hardly ever enough ecological knowledge for an EIA, therefore the EIA process is generally based on experience, and gives relative assessments. However, in strategic assessments of new activities with large potential effects, where experience is lacking, there is a need for a more theoretically based prediction. This has been the case for oil exploration in the Arctic, and therefore emphasis is on the available ecological background information. The focus could give the impression of 'ecological scientism', i.e. that I try to reduce EIA to a simple matter of ecological science. However, I would like to stress that I only focus on one aspect of EIAs among many.

## **1.2 Outline and thesis**

In this study I use the working thesis that the scientific knowledge on Arctic marine ecosystems is generally not adequate to predict the impact of a large oil spill on bird populations. I evaluate this thesis in a review of the current knowledge on the impact of marine oil spill on bird populations (chapter 3) and by analysing the two EIA cases (the Barents Sea in chapter 4 and the Beaufort Sea in chapter 5). The focus in the analysis of the EIA cases is on what ecological science can deliver to the EIA process and how the EIAs manage with what they can get. I have paid special attention to what can be learned from the experience of the two cases, to improve EIA of oil activities in relation to birds in the Arctic. Both experience concerning ecological studies, and experience concerning the use of ecological knowledge in the EIA process are extracted and discussed.

The method used in the case study is described in chapter 3.5.

As background information an overview of EIA and ecological EIA research, with examples mainly from offshore oil activities is given in chapter 2.

## 2 The EIA concept and the use of ecological science

*In this chapter the EIA concept and EIA methods are introduced. It describes how ecological science and knowledge are used in EIAs of extensive offshore oil activities, and how ecological research can be focused for EIA purposes. The general problems in ecology of predicting and detecting impacts are mentioned, as well as recent developments in ecology, which may have the potential to increase the predictive ability.*

### 2.1 History and definition

*A management tool for informed decisionmaking*

EIA is a management tool for officials and managers who must make decisions about major development projects, plans, or policies (Schroll 1995). It is basically a procedure that should be followed in order to avoid significant negative environmental impacts from proposed activities. The concept of EIA comes from the USA where it was introduced in 1969 in the National Environmental Policy Act as a mechanism for informed decisionmaking. The background included among other things, the occurrence of oil spills from offshore oil activities on the California coast and a growing environmental awareness in the public. The EIA was intended “*to provide a full and fair discussion of significant environmental impacts and inform decisionmakers and the public of the reasonable alternatives which would avoid or minimise adverse impacts or enhance the quality of the human environment*” (Council for environmental Quality 1978 cited from Carlman 1996).

*The EIA report*

The EIA instrument consists of two parts: A document called Environmental Impact Assessment Report (Environmental Impact Statement (EIS) in the USA) and a procedure to produce the document including a public debate phase (e.g. MMS 1996). The EIA report is a very important product of the EIA, as it summarise the assessment results and documents the process.

The EIA in the USA was intended to be used in government decisions on major projects, policies and plans. The EIA concept has since been used in a variety of forms in national laws and international conventions. It was implemented as an ECC directive in 1985, it was part of the 1991 Espoo convention (on transboundary pollution) and it was a principle in the Rio Declaration in 1993.

Carlman (1996) reviews the concept for EIAs and concludes that there are some basic principles generally used for EIAs, the so called genuine EIA concept, and he concludes that apart from post monitoring not much new has been added to the concept since it was introduced.

*Strategic EIA*

The concept is usually separated in EIAs on project level (in Denmark VVM is this kind of EIA), and on higher levels (plans and policies) called programmatic or strategic EIA (Programmatic and Strategic

Table 2.1. Tasks in an Arctic Environmental Impact Assessment (EIA) (Arctic Environmental Protection Strategy 1997).

<b>Application of EIA</b>	The decision to conduct an EIA for a project should take into account the special conditions in the Arctic: arctic-specific thresholds and sensitivity criteria are strongly recommended.
<b>Scope of the assessment</b>	The scope of an assessment should include all potential environmental, socio-cultural and economic impacts, especially impacts on the traditional uses of resources and livelihoods of indigenous people and also the consideration of alternatives.
<b>Baseline information</b>	The following key issues should be considered: combining traditional and scientific knowledge, using methods compatible to existing data collection programs in the Arctic, including socio-economic matters, using both qualitative and quantitative information and allowing sufficient time for collecting and compiling baseline information.
<b>Impact prediction and evaluation</b>	Issues identified through scoping are analyzed and expected impacts defined by identifying the type of impacts, by predicting the magnitude, the probability of occurrence and the extent of the impacts and by determining the significance of the impacts. In the Arctic, cumulative impacts are of special concern.
<b>Mitigation</b>	Mitigation aims at avoiding or lessening impacts. In considering mitigation measures, special arctic features should be taken into account and the public should also be involved.
<b>Monitoring</b>	Monitoring should include follow up of impacts, verification of predictions and feedback on mitigation and project operations. The environmental conditions in the Arctic make monitoring a demanding task requiring careful planning.
<b>The environmental impact assessment document</b>	An environmental impact assessment document should be prepared and provided to all involved parties. The document describes the project and its likely impacts upon the environment.
<b>Public participation</b>	An EIA should ensure effective public participation and consultation. Unique features such as the culture, the socio-economic situation and the remoteness of the Arctic should be considered in planning and carrying out public consultations in the Arctic.
<b>Traditional knowledge</b>	In the EIA process, traditional knowledge should be used in the understanding of possible consequences of predicted impacts and in reducing uncertainties.
<b>Transboundary impacts</b>	Assessments of transboundary impacts require project developers and authorities to make allowances for different legal systems, to provide translations when necessary, and to make special arrangements for public participation across jurisdictional borders.

Environmental Impacts Assessments). The purpose of a strategic EIA is to assess cumulative impacts on the environment at an early stage. This report focuses on two cases of strategic impact assessments: The decision to open The Barents Sea and The Beaufort Sea for oil exploration and development.

## 2.2 The contents of an EIA

### *Ecological input*

Ecological knowledge is needed in the EIA process for a description of the environment which can be affected by the proposed activity, and for predictions of the impact of the proposed activities and alternatives. Ecological knowledge and the interpretation of ecological knowledge is thus often an important part of an EIA.

In the appendix to the Espoo Convention the minimum content of an EIA report is defined in nine statements. (1) The purpose of the project, (2) a technical description, (3) a description of alternatives, (4) a non-technical summary and the following five statements that need ecological scientific input:

- 5) *A description of the environment likely to be significantly affected by the proposed activity and its alternatives.*
- 6) *A description of the potential environmental impact of the proposed activity and its alternatives and an estimation of its significance.*
- 7) *A description of possible mitigation measures to keep adverse environmental impact to a minimum.*
- 8) *An explicit indication of predictive methods and underlying assumptions as well as the relevant environmental data used.*
- 9) *An identification of gaps in knowledge and uncertainties encountered in compiling the required information.*

An important point is clearly stated: that the appropriateness of the data and methods used should be evaluated and consequences of gaps and uncertainties should be addressed.

### *The precautionary principle in Arctic EIA*

Within the framework of the Arctic Environmental Protection Strategy (AEPS) guidelines for impact assessments in the Arctic have recently been developed (Arctic Environmental Protection Strategy 1997). The guidelines for the EIA do not differ from the general /genuine EIA concept mentioned previously. However, common Arctic features in climate, ecosystems, sociocultural and economic features, and the general lack of knowledge of the systems and the implications for conducting EIAs are mentioned (Table 2.1). The precautionary principle or approach is emphasised as an important element for an Arctic EIA, where baseline data are sparse, and there are gaps in the understanding of the important ecological functions in the Arctic systems.

The precautionary approach as stated in the Rio Declaration (principle 15) provides: “*where there are threats of serious or irreversible damage, lack of full scientific certainty shall not be used as a reason for postponing cost effective measures to prevent environmental degradation.*” The principle of the precautionary approach has been included in the

international conventions on biodiversity, pollution and climate change.

The EIA concept is included in the Arctic Offshore Oil and Gas Guidelines (AEPS 1997 b) produced by other working groups within the AEPS.

*Dealing with ecological uncertainty*

Of special interest in the context of using ecological knowledge in EIAs is the problem of dealing with uncertainties in data and methods, in the ecological scientific input to the assessment. A working group under the Nordic Council has developed a Nordic proposal for EIA quality criteria (Hilden 1996), including criteria for dealing with uncertainty and methodological problems in the assessment (Table 2.2). As an important point in the quality criteria it is suggested, that there should be a distinction between (scientific) facts, assumptions and expert judgements. And the consequences for the assessment of the range of error in this often complicated blend of facts and educated guesswork should be discussed.

Table 2.2. Quality criteria for dealing with uncertainty and methodological problems in EIA (adapted from Hilden 1996).

Main criteria	Level of detail
Have important uncertainty and data gaps been identified ?	-Are uncertainty and gaps in baseline data described? -Is the basic environmental variation without the proposed activity described? -Is the method used to predict the impact been clearly explained? -Is basic assumptions and boundaries for models and predictions specified?
Have the level of uncertainty and data gaps been addressed and discussed in the assessment ?	-Has the possibility for robust methods been analysed ? -Has the model /assessment been sensitivity-tested ? -Is the predicted / assessed impacts analysed in relation to background-levels including natural variation ?
Have the uncertainty been reduced to a reasonable level considering the extent of the activity and the magnitude of the potential impact ?	-Is there a balance between precision of impact predictions and significance of the impacts ?
Has important problems in the assessment been described ?	-Lack of resources (time, people, qualifications) -Lack of adequate methods -Institutional or structural limitations for the assessment

**2.3 EIA-methods**

*Definition of EIA-methods*

The term EIA-methods are sometimes used rather unspecifically for nearly all methods applied in the EIA. For the purpose of the analysis in this report I will distinguish, as clearly as possible between

ecological scientific methods (complying with normal scientific rules and practises) and EIA-methods defined as the methods used to integrate, analyse or extrapolate the scientific information. So EIA-methods in this definition are tools using and relying on scientific results and methods (baseline data, structure and function of ecosystems, predictive methods) although they are themselves not (ecological) scientific methods (in a strict sense). However, I admit that it is not a clear-cut distinction.

In a Swedish context Hilding-Rydevik (1996) deals with the question whether EIA-methods should be seen as something new or merely developments within old disciplines (natural science, social science, human science and technology). It seems to be a matter of definition where to draw the line, but it is obvious that EIA and EIA-methods are more than pieces taken from the classical disciplines. Elling and Schroll (1992) used a broad definition of EIA-methods in a survey of EIAs (procedures and methods) in USA, Canada and Denmark. They defined EIA methods as all systematic analytic or synthesising procedures used to produce knowledge in relation to the impact of a project (p.21). Methods were seen as derived from (natural) science tradition, technological tradition, social science tradition or interdisciplinary scientific tradition. However, Elling and Schroll (1992) did not find EIA-methods well defined. Within their original disciplines the methods have their certain purpose and applications, which seldom are in accordance with their use in EIAs, where the methods are applied in modified and practical versions.

### *Science and judgements*

My approach to the definition of EIA-methods is based on the same recognition. But I find it important to distinguish between application of methods within their disciplines, where their validity has been proven, and the application of methods or derivatives of a method outside of it's proven field, where it is used as best available option. The latter can be useful and important, but either the validity of the methods has to be proven or the methods should be regarded as an aid for "best professional judgement". The distinction between scientific results and best professional judgement is important both for the explicit description of the uncertainty and possible bias involved, and because it helps to identify research needs and priorities.

The EIA methods have developed mainly through inspiration from decision theory as solutions to the problem of organising, evaluating, composing and amalgamating very different and complex information, from e.g. ecology, human health and economy, into something that can be interpreted and used by decisionmakers and the general public. The EIA methods can be either qualitative or quantitative (e.g. Flanders et al. 1998). EIA methods to help with impact identification are often categorised as checklist, matrices and networks (Bisset 1988, 1992). For impact measurement and prediction more scientific methods are often used where possible. However, in many instances "experts' best judgement" needs to be used in the end, because of lack of adequate predictive models. For impact comparison and evaluation of different options a group of EIA-methods called "index methods" are often used. By scaling and weighting impacts an overall aggregate figure (impact index)



including all impacts, can be obtained for different alternatives. A variety of impact index methods exist e.g. Environmental Evaluation System (Bisset 1995) and Optimum Pathway Matrix Analysis (Cartwright 1993).

### *Index methods and modelling*

Modelling (simulation methods) are used both in ecological science for impact predictions, as a helping tool for making best professional judgements (educated guesswork) of impacts, and also in the scaling/weighing and amalgamating process in some impact index methods (Cartwright 1993). The index methods are good to amalgamate and manipulate the complex information to aid decision-making. However, the subjectivity in these analyses is often, at least for the non-expert, hidden in the apparent objectivity of a calculated figure. As are often also the assumptions and rationale used as basis for the model.

(In the recent Danish debate on the potential impact of global warming, important critic has been put forward on the use of a kind of index method "extended cost-benefit analysis". In this method all benefits, costs and impacts (now and in the future) in a complex model are reduced to one common denominator: money value today. Among other things hiding important ethical and political questions. (e.g. Dubgaard 1998)).

### *Environmental risk analysis*

The term "Environmental Risk Analysis" is often used for impact prediction methods addressing accidental events, where the risk is an expression of the probability and the consequences of the accidental event. Statoil has developed a method for Quantitative Environmental Risk Analysis, which I will use as an example (Klovning and Nilsen 1995). It describes the environmental risk and the establishing of accept criteria in a systematic manner (Fig. 2.1). The analytical method is based on the methodology for statistical risk analysis related to loss of human life. In the analysis the most sensitive biological resource in the affected area is identified (seabirds) and used as indicator to assess the environmental damage. The accept criteria is defined so the most sensitive population may as a maximum be disturbed in 5% of the time. This implies e.g. that a damage which is recovered within half a year in average is an acceptable risk if the calculated risk frequency for the damage is less than one per ten years; and that a damage with an average recovery time of ten years is an acceptable risk, if the calculated risk frequency is less than 200 years.

The Statoil method where an environmental risk criteria model is utilised in a statistical risk analysis appears to provide an alternative to the more conventional "worst case" considerations related to environmental risks. One has however in my opinion to be cautious with this method for two reasons. Firstly, it will tend to hide the uncertainty in the estimated recovery times for seabird populations. Secondly, in the Statoil analysis environmental damages which not recovers within 10 years (classified as serious damage) includes the risk of no recovery. In my opinion, there is a need for additional attention on populations, which risk not recovering at all. It could e.g. be considered if measures supporting the population (beforehand) could be initiated.

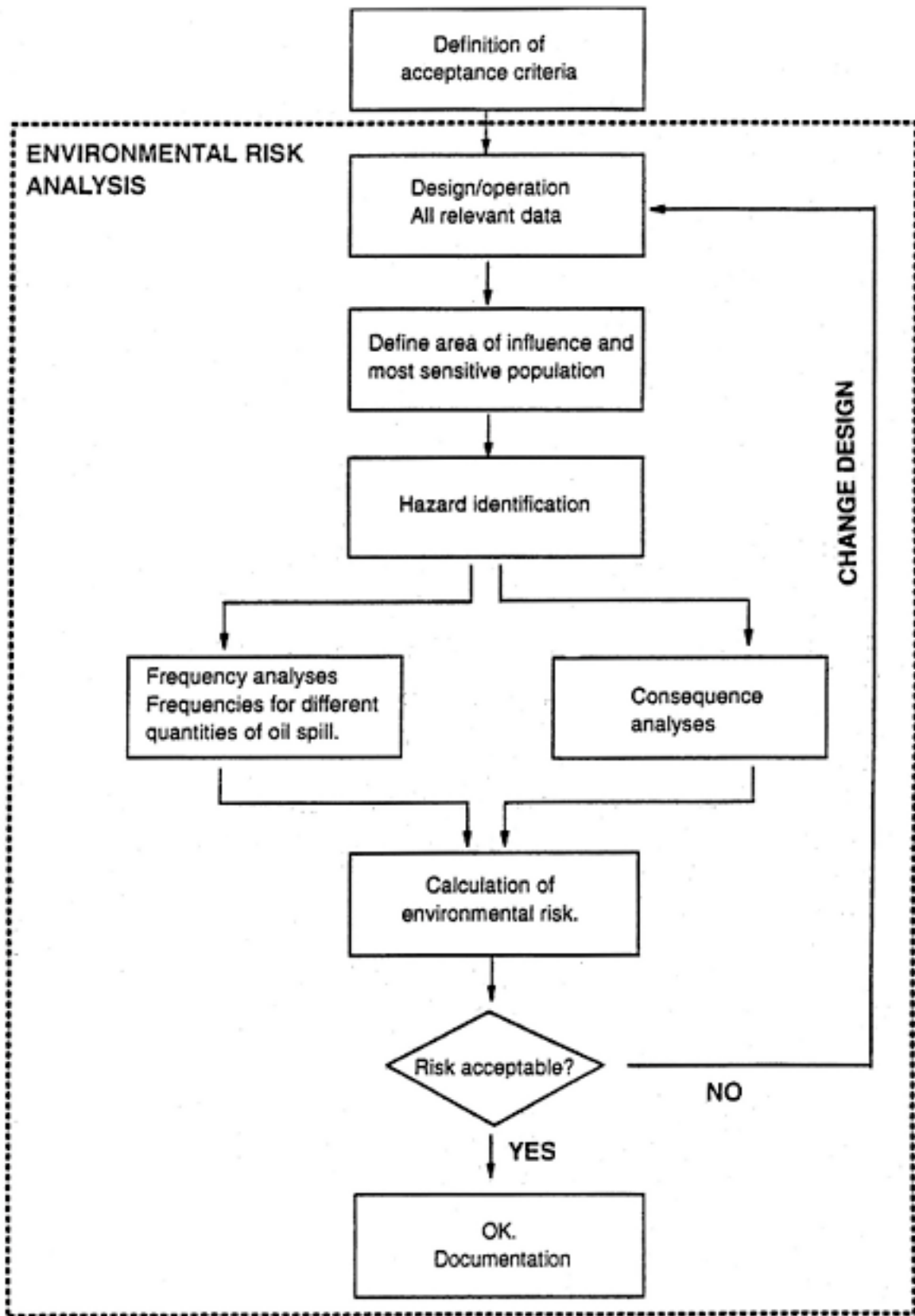

Figure 2.1. Flow diagram for environmental risk analysis (from Klovning and Nilsen 1995).

## 2.4 Focusing ecological research in EIA

The ecological research directly associated to EIAs varies from virtually nothing to large research programs. The Danish strategic environmental assessment of bills and other government proposals (Circular Order from Prime Ministers Office no. 12 of 11 January 1995) is an example of EIAs conducted with existing data and knowledge (§ 7 stk. 3). Although different EIA methods are applied to the existing data (Ministry of Environment and Energy 1995). This kind of EIAs can have considerable importance for facilitation of a qualified political debate of the proposal (Elling and Nielsen 1997, Bo Elling pers.com. 1998). However, the focus in this study is on EIAs, where ecological research is initiated as part of the process, or relating to the process, in order to provide sufficient knowledge for the process and decisionmaking.

### *Selection of research projects*

Of special interest for the interface between EIA's and ecological science is how research topics and projects are selected. In many cases relevant research projects are defined and financed through diverse processes (Research councils, Universities, Applied research institutions, private companies) or through the political system establishing funding-programmes for research in the area of concern, although not directly coupled to an EIA process. In the funding-programmes research projects are typically selected among applications in a bottom-up process from the research community. Selection among project applications is based on a combination of scientific quality and relevance.

### *Adaptive Environmental Assessment and Management (AEAM)*

Holling et al. (1978) in their visionary book *Adaptive Environmental Assessment and Management* addressed the issue of how unsatisfactory uncertainty is dealt with in most EIA's and developed an alternative process called Adaptive Environmental Assessment and Management (AEAM). In an ambitious process the AEAM integrates environmental with economic and social understanding at the very beginning of the design process, during the design phase and after implementation. The AEAM use system analysis to connect ecological knowledge with problems related to the management of the environment. During a series of interdisciplinary workshops a computer model is developed, which includes all relevant linkages for a specific project. In this way the AEAM provides a process for identifying the most relevant (ecological) research projects in order to reduce uncertainty or understand the range of uncertainty. In the entire process there is a feedback mechanism where research and investigations are followed by workshops to adjust the course.

Holling and co-workers' ideas have had great influence on the development of EIA methods for large projects. The methods were used in the Canadian Beaufort Environmental Monitoring Project (BEMP) together with a Canadian study on how to improve the ecological science contribution to EIA (Beanlands and Duinker 1983). BEMP's purpose was to develop an appropriate research programme related to expected petroleum activity in the Canadian Arctic

Beaufort Sea (Everitt et al. 1986). The approach was to use AEAM to develop a computer simulation model of the biophysical processes of the Beaufort Sea. The conceptual model underlying the simulation model provided the framework for the creation of a set of impact hypotheses, while the computer model turned out to be a too difficult task. The impact hypothesis became the basis for the proposed monitoring and research. Here monitoring is defined as a scientific process designed to test specific hypothesis on the causes of environmental impact (it is not just surveillance).

#### *Impact hypothesis*

An impact hypothesis is a set of statements that links development activities with their environmental effects. It has three primary parts: 1) The action - which is the potential cause of an effect; 2) The Valued Ecosystem Component (VEC) or indicator - which is the measure of the effect; and 3) the linkages - the set of statements that links the action to the VEC.

#### *Valued Ecosystem Component (VEC)*

An important development in this study was the use of the concept Valued Ecosystem Component (VEC) for selecting which ecosystem components to focus on and which to exclude. A VEC was defined as *"an ecological component which is important to local human populations, has a national or international profile, and if altered from their existing status, will be important in evaluating the impacts of development and in focusing management or regulatory policy"* and thus incorporates both scientific ecological knowledge and i.a. social scientific knowledge and policy in a broad sense. (It has been said that a VEC is something that gives a politician a headache if something happens to it). The method involves the ranking of both VEC's, impact hypothesis, and research and monitoring programmes associated with the impact hypothesis, in order to find the most relevant and valuable projects.

BEMP had considerable success in directing research and effects monitoring. A majority of the environmental projects funded by government and industry addressed recommendations made through the BEMP impact hypothesis, and made valuable contributions although the computer model not was completed. Concerning the BEMP process it was concluded: *"In reality, impact assessment involves more than technical questions. Many of the questions that arise have no technical or scientific solution.....Modelling workshops provides a rational and realistic way of organising the people and technical aspects of assessing the impact of industrial development. Models help facilitate the technical aspects of planning and workshops help facilitate the people side"* (Everitt et al. 1986).

The experience and methods from BEMP have been widely used and the design and concepts were also used as a starting point for producing the Svalbard equivalent "Assessment system for the environment and industrial activities in Svalbard" (MUPS (Miljøundersøkelser På Svalbard) analysis system) (Hansson et al. 1990). It is an overall co-ordinated plan for assigning priority to environmental studies associated with petroleum activities in Svalbard. The MUPS system differs from BEMP in that from the beginning it was intended to start with a verbal system (instead of computer simulation, which did not succeed for BEMP). In addition there are no aboriginals with special rights on Svalbard.

## *A seabird VEC*

To illustrate the MUPS-system, which was developed at a number of workshops, I have chosen the seabird VEC as example (Appendix 2). A flowchart shows the linkages between impact of encroachment, system component, and VEC. The linkages are used to set up a series of impact hypotheses. For seabirds eight hypotheses were established, evaluated, and classified in four categories. Two hypothesis were considered to be valid and important to test with research, surveys and monitoring, one is given in Appendix 2 together with its documentation and suggested research and monitoring programmes. An expert group selected the VEC's and ended up with 14, mainly "self-evident" peaks in the foodchain. The idea is to select few important VEC's which "cover" potential impact on the important ecosystem processes they rely on through the linkages.

There was a tendency in the initial selection process in MUPS for selecting too many and too "scientific" VEC's instead of mirroring the public interest specific to the area, as intended with the system. Probably reflecting that out of 11 members of the expert group, as listed in Hansson et al. (1990), only two were not scientist or environmental administrators. However, apart from this flaw it is my impression that MUPS came up with a valuable coherent and prioritised research program which is suited to be dynamic and further developed as new information are produced and new situations occur.

## *INSROP and the Dynamic Environmental Atlas*

The methodology described by Hansson et al. (1990) has also been used by Bakken et al. (1996) for selection of marine bird VEC's and description of impact hypothesis in the International Northern Sea Route Programme (INSROP). Part of the INSROP was to work out a Strategic EIA for year-round commercial ship traffic at the Northern Sea Route, from Norway to Japan north of Russia. A simplified AEAM-concept was used for the INSROP-EIA process (Thomassen et al. 1996, Moe et al. 1997). VEC's were used to focus ecological baseline studies. Results from these and multidisciplinary information from other sources were integrated in a computerised Dynamic Environmental Atlas, which became an important tool in the EIA process (Bakken et al. 1997, Brude et al. 1998). The Dynamic Environmental Atlas is a database and geographic information system (GIS), which was used for environmental risk assessment analyses by combining georeferenced information on 1) temporal and spatial distribution of VEC's, 2) distribution of shipping activity in different scenarios 3) activity specific impact factors (like oil spill drift statistics) and it also incorporated species specific vulnerability to the impact factors. Thus the GIS analysis could give a relative representation of the environmental risk within a certain influence area. In a way the INSROP DEA and GIS made a step toward Holling et al.'s (1978) original vision of developing a computer-model of the most important biophysical processes in the AEAM process. However, the INSROP GIS is not a biophysical functional system model but a tool for visualizing and performing more focused unbiased analyses of potential impacts. The INSROP team stress that "*..in EIA work the GIS can never fully replace the professional assessments made by dedicated experts and scientists*" (Brude et al. 1998).

Bisset (1988) outline two trends in the use of methods in the EIA's; the ecological scientific trend focusing on "sound ecological principles" and the trend of extended use of index-type methods. However, *"These index-type methods are not incompatible with scientifically acceptable EIA's. The main strength of index methods is the ability to amalgamate and manipulate the results of EIA to aid decision-making. It is important that the result of EIA be obtained in a scientific manner and that the transformation of the results into notional numbers on arbitrary scales is done in such a way that the validity of the result is not violated"* (Bisset 1988).

After all the predictive ability of ecological science and the ability to test impact hypothesis is crucial for EIAs. In an international survey of EIA effectiveness (Canadian Environmental Assessment Agency 1997), it was the opinion of the majority of the EIA practitioners and managers, who took part in the survey that: *"current practise is unsuccessful or only marginally successful in making verifiable predictions, in specifying the significance of residual impacts, and in providing advice to decision-makers on alternatives."* Thus focusing on a need for improved predictive abilities which in this context means improved understanding of ecological dynamics.

## **2.5 Ecological impact studies**

Studies evaluating EIA and EIA-research supports the conclusion that more research into ecosystem dynamics is needed and that most EIA ecological research (on a project level) does not contribute significantly to the ecological understanding (Schmitt et al. 1996, Treweek 1996). Studies are often too small and isolated. An example is a survey of EIS of 18 coastal projects (Schmitt et al. 1996) which were analysed for the use of biological data, statistical analysis and recommended monitoring. The survey concludes that studies were small and uncoordinated, mainly because the project proponent had little interest in a larger (more time consuming) co-ordinated study that could produce new knowledge. Good after-impact studies to test impact hypothesis using methodology like BACIPS (Before After Control Impact Paired Series) were not conducted.

The BACIPS design is based on a time series of differences between the control and impact sites that could be compared before and after the activity begins (Steward-Oaten 1996). Thus taking into account time trends as well as ecological differences between the control and study site. Often no feedback exists from field assessments / monitoring to the predictions made (and the predictive methods used) in the EIA (Schmitt and Osenberg 1996). A way to avoid the isolated ecological studies related to project EIA, which has little value, is to funnel the research effort into broader strategic studies, as pointed out by Treweek (1996) in a review of ecology and environmental impact assessment. Danish environmental research is to a large extent strategic, however it is mainly financed by public funds.

related to both projects and plans (policies). Much effort has been devoted to benthic pre-impact studies and monitoring (Carney 1996, Olsgard and Gray 1995). Carney (1996) reviewed extensive pre-impact marine benthic surveys in the US Outer Continental Shelf. He found that survey results were only species inventories and delineation of faunally distinct habitats. There was a lack of ecological analyses and ecological conceptual framework for understanding dynamics and ecological importance. He found the studies fulfilling at most a minimum purpose instead of optimum purpose. Where the minimal purpose of pre-impact studies are defined as (A) predict the spatial distribution, abundance and variance of dominant species and (B) the extent to which the fauna contains rare forms. While the optimum purpose provides information on sensitivity of the fauna and the relative importance of the different regions (of the seafloor). Because of the poor outcome of these studies the linkage between study component and the original concern may become lost or moot in the final EIA.

Olsgard and Gray (1995) made a comprehensive analysis of the effects of offshore oil and gas exploration and production on the benthic communities of the Norwegian continental shelf. After 6-9 years contamination had spread from the platforms, so nearly all of the outermost stations, 2-6 km away from the platforms, showed evidence of contamination. Effects on fauna closely followed the pattern of contamination when multivariate statistical analysis was used. While the traditional use of indicator species and diversity indices applied to the data did not identify the same extent of the effects.

However, the improved detection ability also puts focus on the question of ecological significance – and political evaluation – of the measured effect.

### *Scaling of ecological studies*

The problem of scaling is important in designing ecological studies and in interpretation of the ecological significance of the results. It has been addressed with the concept Large Marine Ecosystem Concept (LME) (Sherman 1991). LME's are defined as extensive areas of ocean space of > 200 000 km<sup>2</sup> characterised by distinct hydrographic regimes, submarine topography, productivity and trophically dependent populations (Sherman 1991). The ecological concept that critical processes controlling the structure and function of biological communities can best be addressed on a regional basis is part of the LME approach to research on living marine resources and their management. From a fishery science perspective, realising the big impact fishery can have on an ecosystem, Sherman points to the fact how fishery and natural perturbations can alter the structure and dynamic of LME's generating cascading effects up the food chain to predators including cetaceans, pinnipeds and seabirds, and down the foodchain to plankton.

The story goes that fishery scientists did single-species stock assessments and oceanographers did not achieve any great success in predicting fish yield based on food chain studies until ICES convened a symposium on the North Sea as an ecosystem and since then many broader focused marine ecological studies have been undertaken.

Seabirds are now being integrated into multi-species management of fisheries in the North Sea through calculation of removals based on diet, occupancy and energy requirements (Reid 1997). The topic of change and persistence in marine communities and the need for multispecies and ecosystem perspectives in fishery management relates to the reports of changing states of marine ecosystems (e.g. Gjørseter 1995). Seabirds have been impacted in several examples of cascading effects of fish population collapses: Pacific Sardine in the California Current Ecosystem; the pilchard in the Benguela current ecosystem, the anchovy in the Humboldt current ecosystem and the crash in the capelin stock in the southern Barents Sea ecosystem (Vader et al. 1990).

In a LME study of offshore waters of the Northeast Shelf Ecosystem (USA) Sherman et al. (1996) concludes that the ecosystem does not show any adverse effects of pollution in spite of its use as a source of petrogenic hydrocarbon (and although there are local effects). Measured against increased pollution-induced losses of marine resources it is clear that the major impacts on the living resources of the shelf ecosystem are the result of excessive fishing mortality.

Appropriate scientific design and analysis of impact studies of projects (like BACIPS) as well as emphasis on larger strategic ecological studies of structure and function are important for improving the predictive ability of ecology serving EIA.

#### *Impact trend-by-time design*

However, concerning oil spills, some information can also be learned from actual spills without good baseline data. Wiens and Parker (1995) reviewed statistical designs for assessing the impact of accidents based on experience from the Exxon Valdez Oil Spill. When an environmental accident occurs studies of its effect must be initiated after the accident. Consequently perfect experimental design is not possible, and the methodological issues and ecological assumptions associated with different study designs become especially important. They suggest that an inclination to think first about conducting a “before-after” analysis with inadequate “before” data from available studies is misleading. They recommend instead “impact level-by-time” and “impact trend-by-time” designs. These study designs have the potential to document both initial impact and recovery. The contamination is treated as a continuous variable in time and space and an indicator of impact e.g. habitat use, is measured along a contamination gradient during the recovery period. The ecological assumption is the dynamic equilibrium (not steady state) as with the BACI (Before and After Control Impact) but the latter approach is difficult not knowing where your accident will occur.

It is symptomatic that advanced mathematical and statistical methods often are needed to identify patterns and thus identify effects from the large variation typical of ecological measurements (identify signal from noise) like in the study of Olsgard and Gray (op.cit.).



## 2.6 Modelling

### *Individual-based models*

The predictive ability of ecological science has been prophesied a major breakthrough in the next decade because of new applied mathematical and computational developments. Levin et al. (1997) report in *Science* on the promising use of individual-based models in population and ecological modelling made possible by powerful computers. Such models permit adequate representation of the full statistical ensemble of possible realisations associated with the many stochastic elements, in contrast to deterministic systems with few dimensions. The idea of the individual-based modelling is to identify patterns and to understand how (and which) details at one scale makes clear its signature on other scales through multiple runs and complex statistical analysis. These models will probably first contribute to the development of ecological theory, while applied predictive models seem to be far away.

It seems to be a frequent problem in management of endangered species, that demographic models of population viability are too complex for the available data. In a review Beissinger and Westphal (1998) conclude, that predictions from quantitative models for endangered species are unreliable. Mainly due to poor quality of demographic data used in most applications, difficulties in estimating variance in demographic rates and lack of information on dispersal (distances, age, mortality, movement patterns). Unreliable estimates also arise because stochastic models are difficult to validate, and environmental trends and periodic fluctuations are rarely considered. The form of density dependence is frequently unknown, but greatly affects model outcomes, and alternative model structures can result in very different predicted effects of management regimes (Beissinger and Westphal 1998).

The use of models is a trade-off between including many potential mechanisms and guessing the parameter values, and simpler models with better input.

### *Modelling of bird populations*

Simple modelling of bird population dynamics with constant parameters (e.g. Leslie matrix models) is well developed, while modelling incorporating demographic stochasticity, environmental stochasticity and density dependence is under development in a probabilistic framework (Lebreton and Clobert 1991). Focusing on meta-populations (e.i. dispersal phenomena) is considered the new frontier in bird population modelling (Lebreton and Clobert 1991). It will however take time to develop these models to applications like predicting the resilience of populations. Lebreton and Clobert (1991) concludes, in a treatise on modelling bird populations and conservation, that “*while some generality and realism (in the models) have already been reached, precision will frequently remain out of reach, for reasons of cost, or for intrinsic reasons in case of small populations.*” And also Lebreton and Clobert (1991) suggest that models of adaptive management (AEAM) (Holling 1978) as well as methodology developed for monitoring might be helpful for practical purposes.

## 2.7 Recent developments in ecology

Two developments in contemporary ecological science seem to be important in relation to EIA. The first is the increasingly accepted idea that ecosystems are naturally changing all the time, and the second is the increasing understanding of the importance of biodiversity on the subpopulation level.

### *Ecosystems are naturally changing*

The ecosystem “superorganism” paradigm ignores the degree to which ecological communities are open, loosely defined assemblages with only weak evolutionary relationship with one another (De Leo and Levin 1997), that exhibit characteristic patterns on a range of scales of time, space and organization complexity. Ecosystems are viewed as dynamic cycling through a spiraling developmental path, characterized by different phases. There is emphasis on variability, spatial heterogeneity and nonlinear causation. The new school of thought about ecology that challenge the old equilibrium ideas have been called the “non-equilibrium paradigm” (Adams 1996). Ecosystems have multiple modes of functioning and the potential for unexpected changes in system behavior. We should therefore not in ecological management automatically seek to preserve what must change. We must focus our attention on the rates at which changes occur, understanding that certain changes are natural, desirable and acceptable, while other are not.

### *Ecosystem integrity*

De Leo and Levin (1997) suggest to put the focus on ecosystem integrity, where the notion integrity implies a dynamic view incorporating processes and subjective, defined conditions based on a definition of “use” of the system. What they suggest as useful to characterize in detail is the functional and structural aspects of ecosystems to provide a conceptual framework for assessing the impact of human activity on biological systems and to identify practical consequences stemming from this framework. Ecosystem integrity is not an absolute concept. The existence of different sets of values regarding biological diversity and environmental risks must be explicitly accounted for and incorporated in the decision process rather than ignored or averaged out. In this context De Leo and Levin (1997) advocates *adaptive management* policies to deal with uncertainty and ecosystem complexity.

### *Meta-population concept*

Populations as in equilibrium and density-dependent separate entities regulated by birth and death are now considered outdated (Rhodes et. al. 1996). Immigration and emigration can be more important and periodic local extinction and recolonization can be common. The meta-population concept is the idea that a species is organised into localised groups of interacting populations, occupying one or several habitats. Although the concept developed in entomology, where local extinction is more common the concept may apply in a broad sense to certain bird populations as well (Lebreton and Clobert 1991). It means species and populations is not an adequate concept for organising conservation management; levels below (meta-populations and genomes) and levels above (ecosystems and landscapes) must also be considered (Rhodes et. al. 1996). Dispersal phenomena are for example important for predictions of recovery following mass mortality. Fishery biologist have used the

concept “unit stock” in fishery management for decades for subpopulations. In ornithology recent studies using satellite-tracking, bird-banding, and DNA-studies provides important information on dispersal and interaction of subpopulations (Wooller et al. 1992, Cairns and Elliot 1987).

The problem of understanding and modelling the impact of oil spills on seabird populations, confounded by changing ecosystems and subpopulation (colony) interactions will be discussed in the next chapter.

### 3 The impact of marine oil spills on bird populations

*In this chapter knowledge of the effect of oil spills on birds is summarised as background information for the analysis of how birds and oil are dealt with in the two EIA cases (chapter 4 and 5). Predictive simulation models of population impacts of oil spills are presented and the evidence of population impacts after oil spills are discussed. The chapter ends with a description of the method used in the analysis of the two cases.*

Bird sensitivity due to marine oil spills has received both public and scientific attention. Seabird vulnerability to oil has often been illustrated to the public as oiled birds washed ashore. However, scientific attention has focused on how additional mortality due to oil spills can affect seabirds on the population level, which is the most significant ecological question. Several reviews of birds and oil pollution have been published in the last 30 years: Bourne (1968), Holmes and Cronshaw (1977), Clark (1984, 1987), Leighton et al. (1985), National Research Council (1985), Dunnet (1987), Hunt (1987), Anker-Nilssen (1987), and Wiens (1995) incorporating experience from the Exxon Valdez oil spill in 1989.

The largest input of oil to the marine environment is received in low concentrations from river and urban runoff, bilge water and natural seepage. These discharges are often so diluted that they do not form visible slicks or sheen's at the sea surface, although some natural seeps e.g. in the Gulf of Mexico forms sheen's (0.01 - 1 my) (MacDonald 1998). Large marine oil spills are caused by shipping accidents and accidents during oil transport, production, and exploration. A large number of small spills are caused by discharge of tank residues from tankers and oily residues from ship's engine rooms (National Research Council 1985). It is the large accidental spills and the large number of small spills (chronic) that causes oil slicks on the sea-surface and constitutes a hazard to seabirds.

#### 3.1 The effect of oil on seabirds

##### *Oil coating of the feathers*

Seabirds are vulnerable to oil spills in several ways (Fig. 3.1). Primarily, oil soaks into the plumage and destroys insulation and buoyancy causing hypothermia, starvation and drowning (for reviews see Leighton et al. 1985, Anker-Nilssen 1987). The major effect of oil on feathers is alteration of the structure. The oil destroys the water repellency of feathers by disrupting the precise orderly arrangement of feather barbules and barbicelles (Leighton et al. 1985, Mahaffy 1991).

The oiled feathers become matted and waterlogged and the birds lose buoyancy and the insulating properties of the plumage (Stephenson 1997). This causes a stress on the energy metabolism in

the bird. In experiments an external dose of 20 g oil on ducks plumage at 0°C was found to increase basal metabolic rate to 186 % of the rate of controls (experiments by several authors reviewed in Leighton et al. (1985)). The dose was estimated to be within the range of oiled ducks found in the wild, which was in average 10 g oil/kg body weight for moderately to lightly oiled ducks. For eiders resting on water (instead of standing in air) the thermal stress has been found to be even higher. Jenssen and Ekker (1991) found an almost 400% increase in heat production for eiders resting in water (5.5 °C) after exposure to 70 ml crude oil. The rate of heat loss exceeded the thermoregulatory capacity and eiders became hypothermic within 70 min. after contamination.

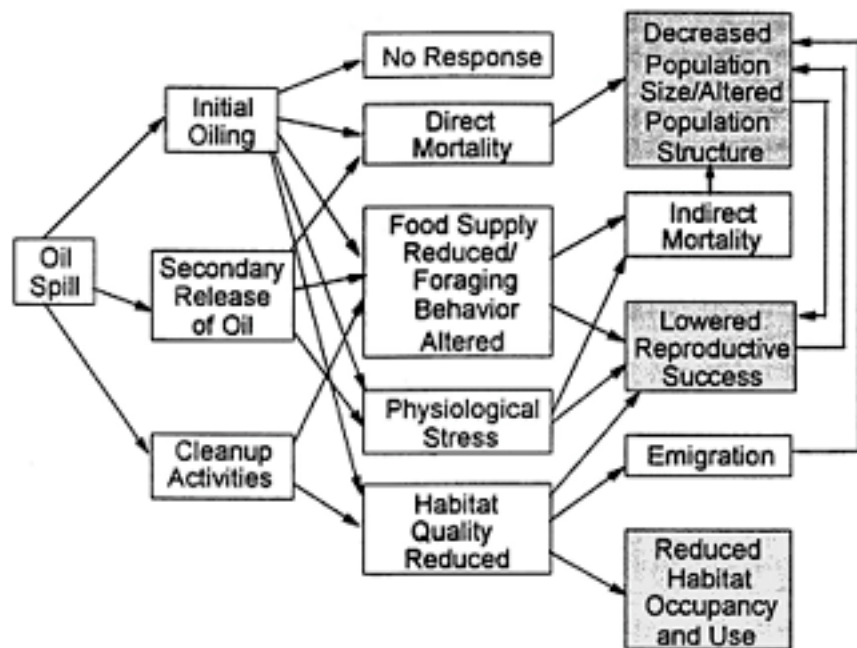

Figure 3.1. A schematic representation of the ways in which an oil spill can influence seabirds. Three primary avenues of effects: population size and structure, reproduction, and habitat occupancy, are highlighted (from Wiens 1995).

Assuming that all the oil an eider comes into contact with on the water surface is absorbed by the plumage. Then an eider will absorb 70 ml oil by swimming through a 6.7 m stretch of an oil slick with a thickness of 0.1 mm, or through a 670 m stretch of a blue-shine with a thickness of 1 my-m.

The experimental studies of Jenssen and Ekker (1991) further indicate that the effect of oil doses are aggravated if birds are allowed to preen oil into a greater part of their plumage, as they do in the wild. Burger (1997) studied the effect of oiling on feeding behaviour of sanderlings (*Calidris alba*) and semipalmated plovers (*Charadrius semipalmatus*) following an oil spill on the Atlantic coast of New Jersey. It was found that time devoted to foraging decreased with the degree of oiling, and oiled birds spend more time preening and standing about than un-oiled birds. This increases the energy stress

during the migration. For aquatic feeders the increased energy demand is combined with a reduced ability to feed, due to loss of buoyancy in the water logged plumage.

Birds feeding and resting on the sea surface like alcid could suffer severe impact from even small oil doses (Leighton et al. 1985). Arctic seabirds are especially vulnerable to the destruction of the insulating capacity of the plumage because they live in cold water. Furthermore, spilled oil will keep its sticky and feather-destructive properties for a longer period in cold water.

#### *Toxic effects of oil*

Birds ingest oil when they attempt to clean the oiled plumage, and when they feed on oil-contaminated food. Ingestion of oil can cause irritation of the gastro-intestine, damage to liver and kidney function, anaemia and dysfunction of the salt gland (Fry and Lowenstine 1985). Many toxicological experiments have been conducted, but the literature is somewhat confusing, primarily because oils have different compositions. The different components have different toxic effects, and the various components have not been adequately specified in most experiments. When spilled oil become weathered it is generally less toxic, because the most acute toxic components evaporate (Prichard et al. 1997). In spite of the fact that there is no comprehensive understanding of the toxic effect, it is clear that ingested oil can be directly and severely toxic. It may also have more subtle effects at low doses, both acute and chronic, that can significantly affect survival and reproduction (Fry and Lowenstine 1985, Leighton et al. 1985).

External oiling is likely to be responsible for the majority of seabird losses after an oil spill, but long-term effects after intoxication may hamper the reproductive capacity by increasing the proportion of non-breeders in the population (Fry and Lowenstine 1985). There are indications that sub-lethal effects may have reduced reproduction capacity in oiled penguins that have been rehabilitated and released in South Africa (Morant et al. 1981 from Fry and Lowenstine 1985). However, these results from rehabilitated seabirds can not be regarded as generally applicable to oiled seabirds. Field experiments have shown that lightly oiled adult birds may transfer oil to eggs when incubating, thereby diminishing the hatching success (Lewis and Malecki 1984).

#### *Intake with food*

After an oil spill the oil gets weathered i.e. the composition shift towards components with low volatility and resistance to light- and bio-degradation. At the same time, the primary pathway of exposure shifts from direct intake (typically related to preening) to indirect intake with the food. Weathered crude oil is generally less toxic than fresh oil. Stubblefield et al. (1995) fed mallard duck (*Anas platyrhynchos*) weathered crude oil (from the Exxon Valdez oil spill) at oral doses or dietary concentrations exceeding those representing maximum likely field exposure from heavily oiled areas. The oil did not significantly affect survival, growth, or reproduction at these concentrations. However, at extremely high concentrations (20 g oil/kg diet) there were significant reductions in mean eggshell thickness and strength. It is assessed based on these results and the toxicological literature that sub-lethal toxic effects of crude oils on

wildlife in spills such as the Exxon Valdez appear to be very unlikely (Hartung 1995).

However, relatively un-weathered oil with toxic properties still remained in protected sediments under rock armour and in some mussel beds in Prince Williams Sound several years after the spill (Spies et al. 1996). Spies et al. (1996) concluded that chronic sub-lethal effects most likely attributable to residual oil occurred for several years (in sea otters, and some fish and invertebrates), although hard evidence is missing for bird species.

### **Seabirds : different lifestyles - different vulnerability**

The more time birds spend on the sea-surface the more susceptible they are to be fouled with oil in the case of an oil spill. Both birds that feed at sea throughout the year (alcids, diving ducks, many terns and gulls) and for a part of the year (some ducks, grebes, divers (loons), phalaropes) can be considered sensitive to oil spills.

The behaviour of the seabirds is varied. Species, which spend most of the time swimming or diving, are most vulnerable to oil. Species that spend most of the time airborne, snatching the food from the surface, are less vulnerable. In any case, most species rest on the sea surface now and then.

Large guillemots (*Uria* spp.) and ducks moult their flight feathers after the breeding season and are unable to fly during 2-7 weeks. Large guillemots and most diving ducks spend this flightless period at sea, where they are safe from terrestrial predators. Most ducks gather in flocks during the moulting period, while the large guillemots (*Uria* spp.) undertake a more dispersed swimming migration.

Birds, which aggregate in small areas on the sea, are more vulnerable than birds, which are dispersed, because a single spill has the potential to affect a significant proportion of the population. High seabird concentrations are found in colonies, moulting and feeding areas, and in leads in the ice during winter and spring. Little is known about whether seabirds deliberately avoid oil slicks; however, evidence strongly suggested that fulmars (*Fulmarus glacialis*) avoided settling on sea surface polluted with heavy oil during a Norwegian experiment (Lorentsen and Anker-Nilssen 1993).

The bird populations, which are believed to be most seriously affected by acute oil spills, are those with a low reproductive capacity and corresponding high average lifespan. This is the strategy adopted by e.g. alcids and fulmars which are typical K-selected species with stable populations (Hudson 1985, Furness and Monaghan 1987, Croxall and Rothery 1991). The size of a seabird breeding population is more sensitive to changes in adult survival than to changes in immature survival or breeding success. This effect is most pronounced in species with high adult survival and low reproductive rate (Croxall and Rothery 1991). However, seabirds like alcids and fulmars with a long life span have delayed maturation. Often pre-breeding and non-breeding individuals ("floaters") in

these populations form a pool that act as a buffer from which individuals may be recruited to replace losses from breeding populations (Dunnet 1982). The length of the delayed maturation may in part be determined of available breeding sites (Dunnet 1982).

### *Population regulation of seabirds*

The non-breeding pool can be seen as an adaptation to natural catastrophes. During prolonged periods of severe storms, making foraging difficult, seabird “wrecks” can occur. One wreck estimated to 25 000 birds, mainly guillemots (*Uria aalge*), occurred in the North Sea in February 1994 (Ritchie and O’Sullivan 1994). The largest reported wreck were 100 000 guillemots in the Gulf of Alaska in April 1970 (Bailey and Davenport 1972, Hudson 1985). The extent to which the effect of an extra oil spill mortality will be additive or compensatory depends on whether extra oil spill mortality will be compensated by relaxation of density dependent regulating factors. Seabird are generally believed to be subject to density dependent regulation although currently there is little clear evidence that it occurs (Wooller et al. 1992), and density-independent environmental effects and parasites may be more important than was hitherto recognized (Croxall and Rothery 1991). However, many population regulating factors are operating. The availability of nest sites in seabird colonies can act as a density dependant factor regulating the breeding populations, especially in a proximate fashion and at a local level. Food availability is considered the factor most likely to limit overall numbers of seabirds (Croxall and Rothery 1991) and this regulation is believed to take place during breeding, where the feeding areas are confined to areas near the colonies (Alerstam and Høgstvedt 1982).

Seaducks have a somewhat different strategy for coping with catastrophic events. They have a higher reproductive potential than e.g. alcid, such that adult losses can be more rapidly replaced, but the population size will tend to fluctuate more.

### **Seabird mortality due to oil spills**

It is often difficult to assess bird mortality caused by an oil spill because only a fraction of the dead birds will beach, and not all the beached birds are found (National Research Council 1985). Results from rather well documented oil spills around the world shows, however, that a substantial number of birds can be affected by medium sized oil spills when the circumstances are bad.

Following a relatively small oil spill (c. 600 t) in Skagarak in 1981 c. 45,000 oiled birds were killed or found dead, and it was estimated that 100,000-400,000 birds died (Anker-Nilssen and Røstad 1982). After the Exxon Valdez oil spill (c. 40,000 m<sup>3</sup>) in Prince William Sound, c. 36,000 dead birds were found. It was later estimated that between 100,000 and 645,000 birds died because of oiling, based on carcass recovery and modelling of recovery patterns (Ford et al. 1996, Piatt et al. 1990, Piatt and Ford 1996). The best estimate may be about 250,000 birds killed by the spill (Piatt and Ford 1996). English drift experiments with marked seabirds corpses gave recovery rates on the shore between 10% and 60 % varying with the distance to the coast and wind speed and direction (RSPB 1979 from Clark 1984).



### 3.2 Predicting population impacts of oil spills with simulation models

As emphasised by Clark (1984, 1987), only mortality resulting from oil pollution which has an impact on a population or community can be considered as biologically significant. This can be evaluated in nature, where oil spills may have had an impact on bird populations. Alternatively, it can be evaluated by creating models, using estimates of the mortality caused by an oil spill and estimated population parameters. Both strategies have been used and are useful, but they both have their limitations in the present fragmentary understanding of the quantitative dynamics of ecosystems.

#### *A density independent model*

Ford et al. (1982) developed simulation and analytical models to estimate the impact of oil spills occurring within feeding areas of colonial seabird populations. The analysis was hampered by the lack of field information on several critical model parameters. The work first of all pointed out features of seabird biology, which merits closer attention, and it gave some general idea of what may happen in an oil spill. In a given scenario, a spill (approximately 620 m<sup>3</sup>) occurs during the middle of the breeding season 24 km from an island with very large colonies of guillemots and kittiwakes (St. George, Pribilof Islands). This results in a 68 % mortality of adult guillemots and 10 % mortality of adult kittiwakes. As a crude first-level estimate, they simulated that it will take 80 years before the guillemot population is back to normal. However, the model used does not account for increased population growth due to decreased competition in the depleted population (density dependence), so the recovery rate will

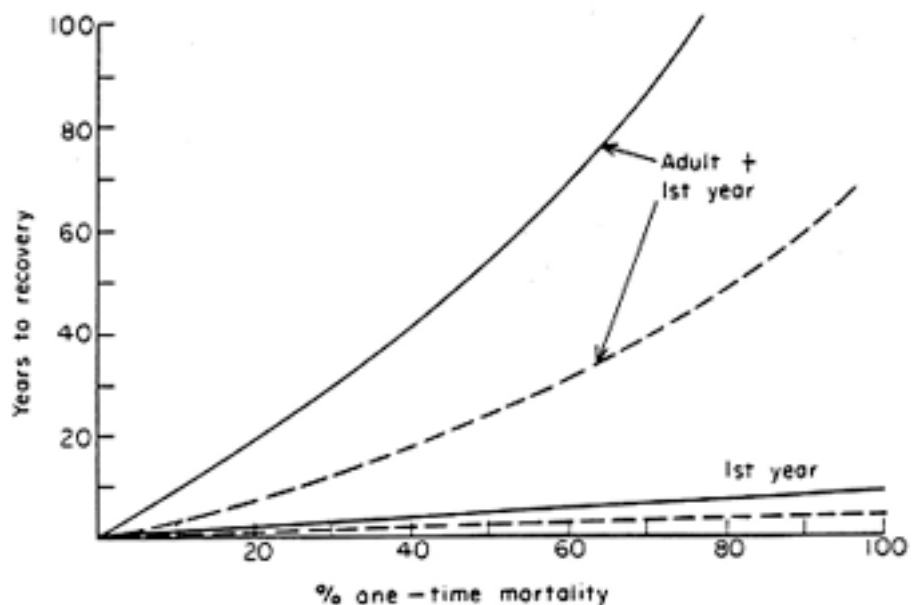

probably be higher.

Figure 3.2. Time to recovery of a stable age distribution and the original population size as a function of one-time mortality for adult and first-year guillemot (*Uria aalge*) (full line) and Brünnich's guillemot (*Uria lomvia*) (dashed line) (from Ford et al. 1982).

The most important factor regarding population impact is the adult oil spill mortality, as could be expected for a long-lived K-selected species (Fig. 3.2). A complete breeding failure in one year may have a lesser effect than a 5% one-time die-off of adults (Ford et al. 1982).

Sensitivity analysis showed that the model is extremely sensitive to the foraging distribution of birds around colonies and to variations in the rate at which a population responds to the occurrence of a perturbation by adjusting its foraging distribution (Ford et al. 1982, Hunt 1987).

#### *A density dependent model*

Samuels and Ladino (1983) developed a model to determine the effects of hypothetical oil spills on seabird populations in the mid-Atlantic region of the United States. Their model was density dependent in contrast to the model of Ford et al. (1982). They assumed the number of young produced per breeding bird to be inversely related to the total adult population size. Using life-table data for common terns they found that if 25 % of all age classes were killed by an oil spill, the tern population (colony) would require nearly 20 years to recover.

However, the form of density dependence used by Samuels and Ladino is largely speculative. Actually if a colony experience a large mortality and no immigration occurs the reproductive outcome per individual may decrease because of a larger predation.

It is difficult to predict the sensitivity to oil spills (and recovery time) for a seabird population. The restitution or recovery of a seabird population is not only the return of numbers but also of population structure. The population dynamics and foraging ecology of the seabirds are complex, and important information for modelling is still lacking (Wiens et al. 1984, Hunt 1987). Because seabirds have a high average lifespan with age-specific survival and fecundity, long-term population studies are needed to give the answers (Wooller et al. 1992). If an oil spill kills all the birds in a colony, the recolonisation and population recovery will depend on the size and location of neighbouring colonies (Cairns and Elliot 1987). It will also depend on the extent of movements of seabirds between colonies (meta-populations), on which there is a lack of information (Wooller et al. 1992).

Although we need important information for making realistic models of seabird population responses to oil spills, models can be useful tools. If the basic model concept is correct, modelling, and sensitivity analysis of models, can give valuable knowledge on which information is mostly needed for improving model predictions; and not the least, on the relative sensitivity of different areas, periods and seabird species (Wiens et al. 1984, Hunt 1987, Anker-Nilssen 1988)

### 3.3 Evidence of population impacts after oil spills

#### The Exxon Valdez oil spill

The Exxon Valdez oil spill in Prince Williams Sound is the most studied oil spill ever. In March 1989 the super-tanker ran aground and spilled 42 000 m<sup>3</sup> crude oil under calm conditions. However, a northerly gale blew the oil slick onto many hundred kilometres of Prince William Sound beach. Within few weeks the spill extended more than 900 km from the spill site along the northern coast of the Gulf of Alaska. Many studies of the impact on birds have been conducted. Effects on birds could be expected: on habitat occupancy and use, on population size and structure and on reproduction. Studies were centred on government institutions and around a group of scientist funded by Exxon. For legal reasons these groups worked without normal scientific communication for 4 years.

#### Two research groups

The Exxon group was headed by a much esteemed scientist (J.A. Wiens). This group focused in their field work on habitat use and abundance at sea of marine associated birds in Prince Williams Sound (see below), evaluation of toxic properties and potential toxic effects for birds (Stubblefield et al. 1995, Hartung 1995), but the group also assessed population impacts on guillemots (*Uria* spp.) (Boersma et al. 1995, Erikson 1995) and bald eagle (*Haliaeetus leucocephalus*) (White et al. 1995).

Government scientist focused on estimating total direct mortality (Ford et al. 1996, Piatt and Ford 1996), and especially on broader studies of population development of e.g. guillemot (*Uria aalge*) (Piatt and Anderson 1996), kittiwake (*Larus tridactylus*) (Irons 1996), black oystercatcher (*Haematopus bachmani*) (Sharp et al. 1996), pigeon guillemots (*Cephus columba*) (Oakley and Kuletz 1996), marbled murrelet (*Brachyramphus marmoratus*) (Kuletz 1996) and bald eagle (Bernatowicz et al. 1996).

Murphy et al. (1997) compared pre- and post-spill bird abundance based on boat surveys in ten bays in Prince Williams Sound that had experienced different levels of initial oiling. The data were both analyzed as a simple before/after baseline comparison and as a pre/post paired design like a BACI design (Before After Control Impact). It was found that (only) three out of eleven taxa had declined significantly compared to surveys 4-5 years before the spill. The pigeon guillemot (*Cephus columba*) was the only species which is both common during summer and showing consistent declines in overall abundance compared to pre-spill data.

Day et al. (1995, 1997) used data from the same surveys and analyzed the abundance of 42 species of marine-oriented birds in relation to an oiling gradient. In order to minimize confounding natural variance 26 habitat features of the bays were included in the analysis as well. In this analysis six species showed no clear evidence of recovery at the final survey 2.5 years after the spill (2 grebes (*Podiceps* spp.), 2 diving ducks, common gull (*Larus canus*) and northwestern crow (*Corvus caurinus*)), while the majority showed no initial effect (23 species) or they were recovering (13 species). The six species that

had not recovered 2.5 years after the spill tended to be intertidal feeders and resident. However, resident intertidal feeders was also found among species that did not show initial impact, or did recover within 2.5 years.

#### *Considerable resiliency*

The data set from the boat surveys was also used for an analysis of (bird) community-level impacts (Wiens et al. 1996). Six avian guilds were defined in order to focus on community-level impacts rather than individual species. The study found that the oil spill had significant initial impact on marine bird community structure, and there were clear differences between heavily oiled and un-oiled bays in 1989. However, by late 1991 none of the community measures indicated continuing negative oiling effects, although a few species continued to show spill impacts. It is suggested that both habitats and bird populations have considerable resiliency to severe but short-term perturbations. Seabird population dynamics may be working out on very large spatial scales so the effects of localised perturbations may be buffered or diffused over regions much larger than the immediate spill area (Wiens et al. 1996).

Recent pre-spill seabird census data were sparse in 1989. However the available data indicated that for several species (e.g. kittiwakes, guillemot, marbled murrelet and pigeon guillemot) there was for unknown reasons, a declining population trend already before the spill. Thus confounding the interpretation of injury from the spill, and focusing assessment of effects to comparing oiled and non-oiled areas. Results achieved by the government scientists included that kittiwakes chick productivity was lower in oiled than in non-oiled areas (Irons 1996). There were greater declines of pigeon guillemot on oiled shorelines, than on non-oiled shorelines (Oakley and Kuletz 1996). And bald eagle nesting success was lower in the oiled part of Prince Williams Sound in 1989, than in the eastern non-oiled part (Bernatowicz 1996).

To test whether ingestion of weathered oil affected pigeon guillemot nestlings, a controlled dose-response experiment was conducted in the field (Prichard et al. 1997). The results suggest that the doses of weathered Prudhoe Bay oil (max. dose 2 x 0.2 ml) administered to the nestlings were not sufficient to induce a persistent inflammatory response.

#### *The large guillemots (Uria spp.)*

The problems of identifying the impact of the spill from natural variation and long-term ecosystem change can be exemplified with the case of the guillemot and Brünnich's guillemot (large guillemots - *Uria* spp.). There were well-documented short-term effects with immediately depressed numbers in the spill-zone, and an estimated 250 000 seabirds killed by oil, of which 74 % were guillemot and Brünnich's guillemot (*Uria* spp.) (Piatt and Ford 1996). Pre-spill data from the 1970s were available and a comparison between pre-spill and post-spill data (1989-1994) showed population declines, reduced breeding success, and delayed breeding phenology. Populations remained depressed, but breeding success and phenology gradually returned to normal levels by 1993 (Piatt and Anderson 1996). A survey of the colonies in the Gulf of Alaska in 1991, by Erickson (1995) from the Exxon sponsored group, showed somewhat

contrasting results. He found that *Uria* spp. were present at all colonies in the path of the spill and attendance numbers were generally within historical ranges. Thus no impact could be detected.

A later dispute (Wiens 1996, 1997, Piatt 1997) revealed, that although census counts of *Uria* spp. colonies conducted in 1991 by both sides were remarkable well correlated ( $r^2=0.97$ ), different interpretations were reached because of different selections of historical data. For example, at one locality Erikson (1995) used a best guess estimate of 25 000 for pre-spill conditions to assess population changes. At the same locality Piatt and Anderson (1996) used 40 000 for pre-spill conditions, which was the mean of the highest and lowest historical count. “*Everyone use the same data sets, but selectively with regard to interpreting population trends*” (Piatt 1997).

The immediate loss was about 7% of the total Gulf of Alaska *Uria* spp. populations and was not considered a drastic occurrence for a species as resilient as the guillemot; at least this percentage of *Uria* spp. populations dies annually from natural mortality (Piatt and Ford 1996). However, some early predictions of the recovery of *Uria* spp. colonies (Piatt et al. 1990) suggested 20 to 70 year recovery times based on demographic models (Ford et al. 1982). These models assume stability of the marine ecosystem and this assumption is invalid, as there was considerable long-term changes in the Gulf of Alaska Marine Ecosystem (Spies et al. 1996).

Piatt and Anderson (1996) conclude that available data are inadequate to distinguish between long-term effects of the Exxon Valdez Oil Spill on *Uria* spp.s and a natural response of *Uria* spp.s to long-term changes in their marine environment. “*Nonetheless, evidence suggest that current conditions in the Gulf of Alaska are not conducive to a more rapid recovery of murre (*Uria* spp.) populations. Until we achieve a much better understanding of long-term cycles in the marine environment and factors influencing seabird demography, predictions about long-term impacts of oil pollution on seabird populations will remain largely speculative*” (Piatt and Anderson 1996). While Piatt and Anderson (ibid.) thus admit that they lack necessary data to draw strong conclusions, Wiens (1995) argue *that* “*biological systems are so variable that the effects of oil mortality were probably biological insignificant and, in any case, statistically undetectable.*” However, because we do not understand the population dynamics and dispersal phenomena, we cannot detect impacts unless they are very large.

### **The Braer oil spill**

In January 1993 the tanker “Braer” ran aground at Shetland and spilled 85 000 ton of light crude oil. Due to severe wind and wave conditions a conventional slick did not form. The oil was thoroughly mixed into the turbulent sea and moved with the currents. Due to the lack of a slick the direct mortality of birds was low (1500 -1600 found dead) compared to other spills and periodic “wrecks” of seabirds due to prolonged periods of storms making foraging difficult. Populations of shags and black guillemot in the immediate area of the spill were reduced, but there were no effect on breeding success

in these or any other species, reported in the official spill report (Ritchie and O'Sullivan 1994).

However, although standard monitoring of breeding parameters did not show effects of the oil pollution, a detailed study of kittiwakes (Walton et al. 1997) has shown sub-lethal physiological effects. Effects that potentially could have an effect at the population level due to missed breeding years and disruption of colony structure. Walton et al. (op. cit.) studied a kittiwake colony and collected an extensive data set during three years prior to the spill. The kittiwake colony is only 4 km distant from the spill site, but the spill occurred 4 months before the onset of kittiwake breeding. In the year of the spill (1993) there were an unusual low return rate of breeders from 1992 (44 %) in the colony, and the birds in the colony revealed a significant sub-lethal level of anaemia. The low return rate was not due to low survival. It was the consequence of adults missing one or more breeding attempts, which appears to be unusual for the species. The main food (lesser sand eel, *Ammodytes* spp.) had very low levels of hydrocarbons and other seabirds feeding on them (Arctic tern, shag, and guillemots) showed no effects. The most likely explanation is that the kittiwakes, which missed breeding, had been intoxicated during pre-breeding gatherings at a freshwater area, which was heavily polluted due to oil mist during the incident (Walton et al. op.cit.).

### **The Northeast Atlantic Case - The cumulative impact of many spills**

Clark (1987) did a general analysis of the importance of oil spills for the population trends in alcid colonies in the Northeast Atlantic. He suggests that the decline in southern alcid colonies on both sides of the Atlantic probably is caused by primarily climatic factors. Clark concludes that from a scientific point of view, the loss of several hundred thousand seabirds in European waters annually (mainly ducks and large guillemots (*Uria* spp.)) as a result of oil pollution, does not appear to be beyond the capacity for these birds to maintain their populations. He thus addressed the cumulative impact of the chronic oil pollution from many spills in the North Sea, which could affect adult survival significantly. Recent beached bird surveys now indicate a decline in chronic oil pollution in the North Sea (Camphuysen 1998).

### **Extirpation of colonies**

The extreme case is: can populations become extinct in oil spill catastrophes? Historical examples show that bird populations in general can recover from very small populations (Ryan and Siegfried 1994). "*Populations as small as several hundred individuals have a very good chance of survival, particularly given monitoring of the populations demographic parameters to give early warning of impending problems*". (Ryan and Siegfried 1994). However, extinction of bird species has occurred mainly due to habitat destruction and hunting (e.g. the former very abundant passenger dove (Bucher 1992) and the great auk (Lyngs 1994)), and seabird colonies have been deserted, with oil pollution as a major factor.

Marginal populations such as puffins at Brittany, at the southern border of their distribution, have been affected. Here a puffin colony crashed due to a combination of natural causes and oil pollution following the Amoco Cadiz wreck at the coast of Brittany (Hope Jones et al. 1978 cited from Clark 1984). This colony was later restocked with puffins from the Faeroe Islands (Duncombe and Reille 1980 cited from Clark 1984). In southern California the guillemot colony on Devil's Slide Rock was extirpated in the 1980's, mainly due to a number of oil spills (Parker et. al 1997). Recently this colony has been recolonized using social attraction techniques (Parker et al. 1997). The disappearances of puffins and guillemots from the English Channel Coast during World War II probably also relates to oil spills as a result of the enormous pollution from sinking and burning ships (Gaston and Jones 1998).

### **3.4 Discussion - Prediction of population effects**

The focus has been on the population level both in impact assessments and in the associated research. Populations are a readily understandable and apparently operational entity, and it is the most important concept in management of marine living resources. However, as researches dig into population theory reality is much more complex, and the notion "impacts on the population level is what matters " become less easy to operate with. Modelling changes in population size is very complex. The identification of key intrinsic (genetic physiological etc.) and extrinsic (resources, competition etc.) factors that influence changes in population size has always been in focus in population biology. However, it has become very clear that closed population models assuming equilibrium values for population parameters are not appropriate for most natural populations. The meta-population concepts: the idea that a species might be organised into localised groups of interacting populations, occupying one or several habitats seems to be able to explain more of the population dynamics. It is more realistic, however, also very complicated.

Because the dynamic of the population is so complex, small impacts on populations can have importance on the population level and sometimes not, at least in theory. Here we are at an important point: the gap between theory and experience (population specific knowledge). Applying the theories and letting data gaps "be in favour of the environment" many scenarios can come out with serious impacts. However, experience from spill events generally exemplify the resilience of populations. In the course of evolution populations have developed strategies to handle natural "catastrophic events" caused by weather or food-shortage. A single catastrophic event whether natural or human induced can be compensated within a limited time. However, the total "environmental stress/pressure" determines the cause of the population, and any extra pressure on a population can in due time result in an unwanted (and unforeseen) impact. Although ecological and population theory development are in the fast lane the day where we have the necessary data to make useful statistical models

for assessing long-term impacts of human perturbations seems beyond the horizon.

In conclusion, major oil spills do have the potential to deplete bird populations and single seabird colonies may be deserted. However, experiences from spills indicate a considerable resiliency of seabird populations to single catastrophic events. It is unlikely that an oil spill can wipe out a seabird population unless other factors, such as hunting and by-catch in gillnets hamper the recovery of the population, or the population is small and has a very restricted distribution.

This conclusion stresses the importance of a holistic approach to the management of seabird populations in relation to EIA of oil activities in the Arctic, where the oil activities introduce a new risk to the seabirds. Since it is inevitable that there will be a large uncertainty on impact predictions of large oil spills, it is important, that populations are not already under severe stress from e.g. hunting or by-catch in gillnets, if major impacts of oil spills are to be avoided.

If populations are under severe stress, their natural capacity for resiliency can not be counted on. An example could be Brünnich's guillemot colonies in West Greenland, which has been declining for decades due to hunting, disturbance and by-catch in gillnets (Kamp et al. 1994, Boertmann et al. 1996). Many large colonies have been abandoned, and the colonies have not been re-colonised, although by-catch in gillnets and the detrimental spring and summer hunting has almost ceased. The total population in West Greenland is still rather large, but we do not know how the colonies (meta-populations) interact, and recolonization or restocking of extirpated colonies seems to be a difficult process (Parker et al. 1997).

### **3.5 Methods in the comparative case study of EIAs**

Two cases of strategic EIA of the decision to open Arctic marine areas for oil activities, the Beaufort Sea and the Barents Sea, are analysed. The purpose of the analysis, is to see what can be learned on how to deal with the potential impact of oil spills on bird populations; in ecology as well as in EIAs in the Arctic.

The analysis makes a general comparison of the ecological approach and a specific comparison of predictions of impacts on seabird populations and tries to track down links between research and final utilisation. It is thus a combination of a study of ecological methods and a social science analysis of the use of ecological science in EIA.

#### **Analysis of cases**

*Starting with the EIA-reports*

The analysis of the two cases starts with the EIA document and goes back through available documents to the scientific basis or lack of it.

*Focus on seabirds*

The analysis focuses on birds and asks a number of questions about the baseline knowledge approach (Table 3.1) and the modelling and analysis approach (Table 3.2) in the EIAs. The results are presented in a descriptive outline for each case, and an evaluation is made as to



whether statements in the EIA document are based on scientific evidence, assumption, or expert judgement. Quality criteria for dealing with uncertainty and methodological problems in the assessment are discussed based on the criteria listed in Table 2.2.

*Science in EIA context*

To view the role of ecological science in the EIA cases in a broader perspective, a number of questions are asked to the context for the EIA document, and how the scientific knowledge is used in the document. The questions concerning the context (Table 3.3) have been formulated under the inspiration of Flyvbjerg (1991) and follow to some extent, Flyvbjerg’s guidelines for the progressive phronesis.

*Progressive phronesis*

The Greek word phronesis means “prudence” that is “practical common sense”. It is one of the three intellectual virtues: episteme, techne and phronesis, defined by Aristotle’s. Episteme is based on analytical rationality producing generalised universal knowledge typical of natural science. Techne is craft, art and technology, it is practical and aims at producing something. While phronesis is the ethical analysis of values and interests in a practical context. It is the intellectual activity used to take practical and wise decisions, where you can not only rely on the generalised episteme knowledge. Based on the concept of phronesis, Flyvbjerg (1991) developed a social science (or planning science) methodology called progressive phronesis and typically used in case studies. The main ideas include being close to or involved in praxis, going into details that might turn out to exemplify important aspects, and focusing on values, power and interests. In this study the method has inspired to a focus on conflicts and details that is found to exemplify important aspects in relation to the role of ecological science in EIA.

*Study limitations*

However, the study of the two cases is somewhat limited due to the sole reliance on published reports and papers. Thus the questions asked (Table 3.1-3) have only been addressed in the analysis where sufficient information has been available.

The analysis also reflects my background. I am involved in a similar EIA case on oil activities offshore West Greenland (see preface) and do therefore focus on problems and experience relevant in this context. My focus is probably coloured primarily by my profession as ecologist, my institutional connection (government applied research institution), and a wish to find out how to give a fair and professional description of the environmental risk involved, with focus on prevention of long-term damage.

Table 3.1. Basic questions to baseline knowledge approach

Numbers and distribution	
	Is it based on existing knowledge or new studies ?
	Are numbers and distribution estimated for all species ?
	What are the main survey methods used ?
	Is special effort devoted to certain species ?
	How are these species selected / criteria ?
	Is local knowledge used ?

Ecology and population dynamics	
	Is it based on existing knowledge or new studies ?
	Are population trends known ?
	Have natural mortality or other basic parameters been assessed ?
	Have other human impacts been assessed or evaluated ?
	Is local knowledge used ?

Table 3.2. Basic questions to modelling and analysis approach.

Assessment of potential impact of oil spills	
	Are scenarios with oil spill drift models used ?
	Is potential direct bird mortality estimated ?
	Are sub-lethal (reproductive) effects considered ?
	Are ecosystem (food chain) effects considered ?
	Are population recovery times estimated ?
Oil spill sensitivity analysis	
	Which factors/parameters are included in the analysis ?
	Are species, population or area sensitivity ranked ?
	Which mitigative measures are suggested ?
	Are local use and local values reflected ?
Limitations	
	Are the limitations of the assessment stated explicitly in the EIA ?

Table 3.3. Basic questions to the context for the EIA document.

The EIA document	
	Why is it produced (legal, political) ?
	Who is the responsible publisher ?
	Who has written /produced the contents ?
	Who is the target group ?
	Scientific statement, by reference or by citation ?
	Can scientific statements be traced back to scientists and scientific publications ?
	How are values (-based judgements) in relation to science presented ?
The EIA process	
Values and science	
	Where are we going ?
	Is that positive ?
	What should be done ?

Scientist in the power play	
	Who are the stakeholders and what is their structure ?
	Who will loose and who will win ?
	How are the power relations ?
	Have the limitations/reliability/uncertainty of the analysis been controversial ?
	Where am I and this study in the play ?

*The Barents Sea and  
The Beaufort Sea*

**Selection of the cases**

Only few well-documented EIAs of opening marine Arctic areas for oil activities exist. The Beaufort Sea and the Barents Sea EIA cases were selected as the most comprehensive, well-documented and recent Arctic EIA cases. Both represent large marine areas, which can be considered as constituting major parts of large marine ecosystems (sensu Sherman 1991). Both cases are exceptional among EIAs because of the large associated research programs initiated to be able to make predictions. A concerned public opinion was also in play in the two cases. The cases are selected as critical cases in the sense (Flyvbjerg 1991 p. 150) that if these cases do not succeed in making good predictions of the impact of an oil spill, it is not likely that less comprehensive or older EIAs succeeded. Furthermore, the two cases represent two very different Arctic marine ecosystems and two different political and scientific environments (North American and North European).

An older (1970's) EIA of Lancaster Sound in Canada as well as EIAs from lower latitudes from both Norway and Alaska was also considered. The EIA of Lancaster Sound was remarkable as it resulted in a decision to postpone oil activities due to lack of environmental knowledge

*Part of the Arctic Ocean*

Both the Beaufort and the Barents Sea are part of the Arctic Ocean as defined by the limits of the most northerly land on the Northern Hemisphere. The ecosystem in the Arctic Ocean is governed by water masses, rather than isotherms, and it is well defined biogeographically (Dunbar 1982). The Arctic zone is defined by its water of upper Arctic Origin i.e. "The Arctic Water Mass". It has the coldest and least saline water in the upper 200-250 m, and flows south along East Greenland and through the Canadian archipelago. The mixing of Arctic and non-Arctic water defines the Sub-Arctic zone. The in-flowing water is of Atlantic and Pacific origin (ratio 5:1). Atlantic water is flowing in both west and east of Svalbard, and Pacific water is flowing in through the Bering Strait. The Barents Sea is in the Sub-Arctic zone, with a large input of Atlantic water. The Beaufort Sea receives only a small input of Pacific water, and only the southern part is considered Sub-Arctic while the northern part is Arctic.

*Available material*

For practical reasons the study is limited to the available written sources, although I have had discussions with people that were

involved in the two cases. The most important documents included in the analysis of the two cases are mentioned below.

From the Barents Sea EIA the most important materials in the analyse is the EIA-report (Børresen et a. 1988), a pre-assessment report with study proposals (Prestrud 1986), the background report with the seabird assessment (Anker-Nilssen et al. 1988), and a report describing the seabird assessment method (Anker-Nilssen 1987). Furthermore, the final document from the Oil and Energy Department to the Norwegian Parliament with the proposal to open The Southern Barents Sea for oil exploration is analysed.

From the Beaufort Sea EIA the most important material in the analysis is the Draft and Final EIA reports (MMS 1995, 1996). These documents are comprehensive and include method descriptions, comments received and to some extent a description of seabird background data. These EIA reports refer to earlier EIA reports from the area, which are also included in the analysis (MMS 1984, 1990). As is also seabird information used in the EIA and published in the scientific literature (e.g. Johnson and Herter 1989, Barnes et al. 1984). During the course of the study I became aware that the US national Research Council had conducted an assessment of the information used in the EIAs in the Beaufort Sea for the U.S. Congress (National Research Council 1994). This report was included in the study.

The analysis of the cases is presented in a chapter for each case, and comparison of the cases is done in the discussion chapter. For each case the analysis starts with an introduction to the marine ecology in the area, and major ecological research programmes are mentioned.

## 4 The Barents Sea Case

### 4.1 Ecological presentation

The Barents Sea borders the permanently ice covered Arctic Ocean to the north and land at approximately  $71^{\circ}$  N to the south. Although the Barents Sea is at the same latitude as the Beaufort Sea, it has a different climate, oceanography, and ecology. The sea is much warmer in the Barents Sea with little ice in the southern part (Fig. 4.1), primarily due to a large influx of nutrient rich warm Atlantic water from the Gulf-stream. The influx mixes with the coastal water and gives rise to a large biological production.

*Focus on southern part*

In this part I deal with the Norwegian part of the Barents Sea, and focus on the southern part (south of  $74^{\circ} 30'$  N) where oil exploration was the topic for the EIA. However, impacts could extend beyond this limit. There are approximately 200,000 inhabitants on the coasts in the area, and there has been important fishing and hunting for centuries (Hacquebord et al. 1995).

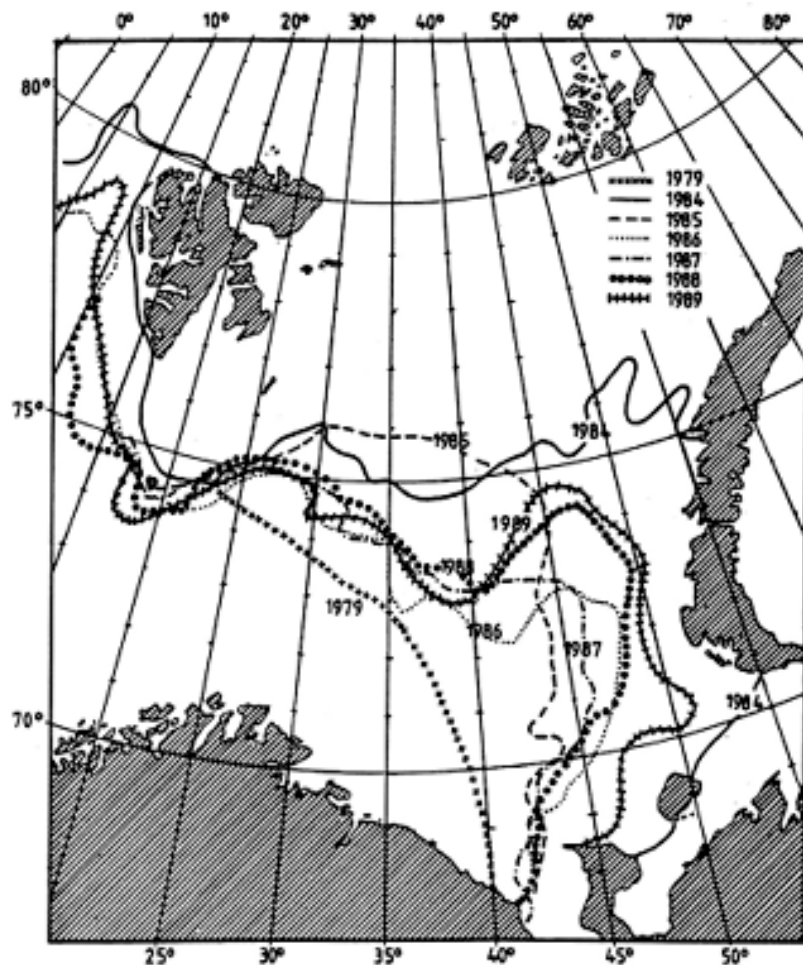

Figure 4.1. Maximum ice coverage in the Barents Sea during winter in 1979 and the period 1984 - 1989 (from Loeng 1991)

The Barents Sea is a typical high-latitude marine ecosystem characterised by short foodchains with few important species and considerable seasonal variation, and variation from year to year. A simple pelagic foodweb is given in Fig. 4.2.

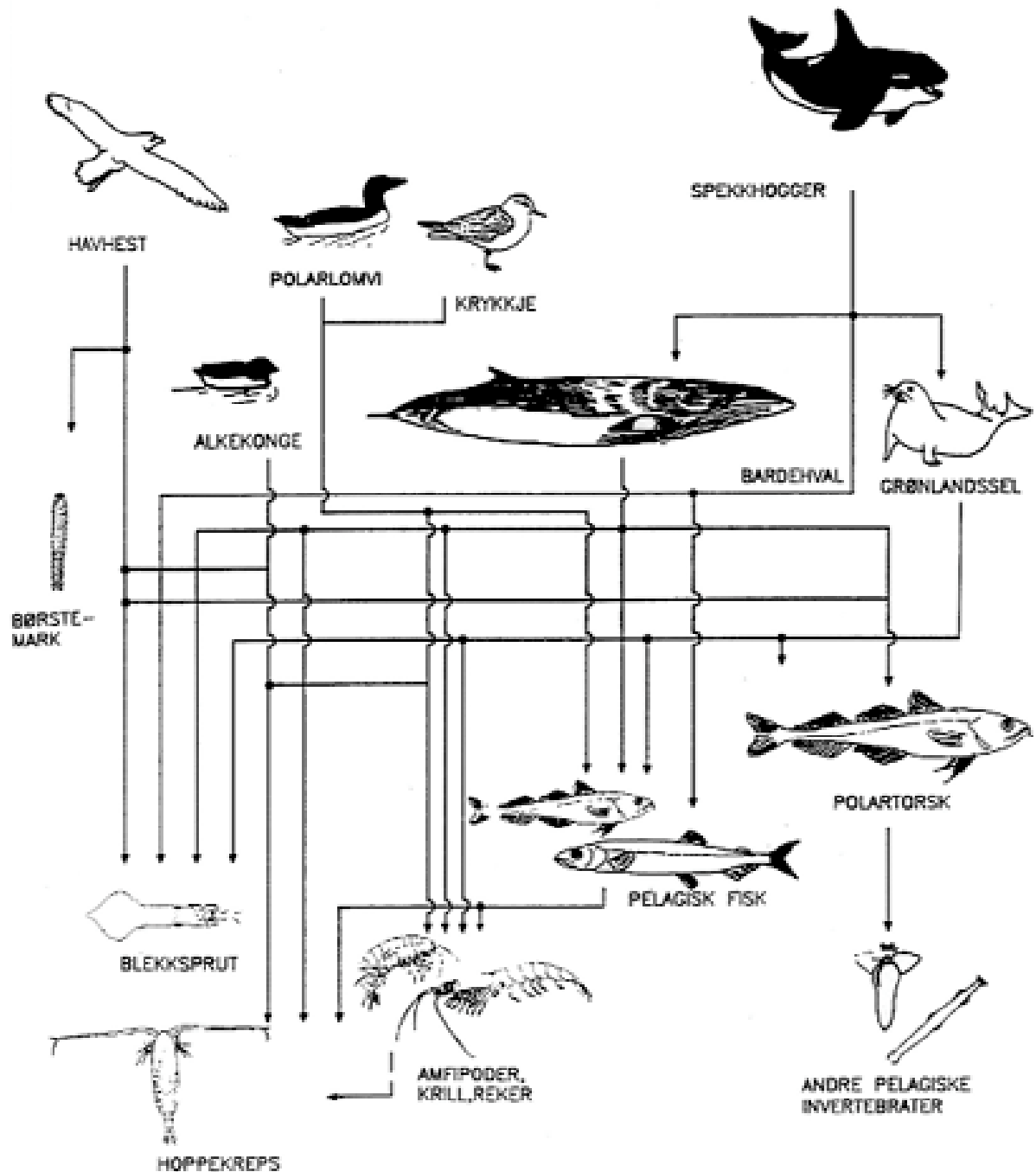

Figure 4.2. Simplified pelagic foodweb (from Sakshaug et al. 1992). Copepods (“hoppekreps” lower left corner) are an important link between the primary production and higher trophic levels.

### *ProMare ecology program*

Realising the importance of the Barents Sea, and the lack of understanding of the dynamics in the system a large marine ecology scientific program (ProMare) was started in 1984. The program ceased in 1989 and major results were published in proceedings (Sakshaug et al. 1991), in a book aiming at a larger audience (Sakshaug et al. 1992) and a synopsis (Sakshaug et al. 1994). The aim of the program was “*to increase the understanding of how the pelagic ecosystem function and thereby improving the basis for government decision-making and as well as elevating the scientific competence both with respect to fish stock management and for the evaluation of the effect of pollution*”. The total cost of the ProMare program was about 95 million Norwegian kroner. Scientists participated from 4 universities as well as from the Institute of Marine Research in Bergen and the Norwegian Polar Research Institute. The focus of the program was on basic research in the structure and dynamics of the system, in contrast to the EIA study program mentioned later. Most of the information in this ecological presentation is from this program. However, only few ProMare studies were reported and used when the EIA report was compiled in 1988.

### *Shallow shelf area*

The Barents Sea is a shallow continental shelf area influenced by three water masses: the high-saline high-temperature Atlantic water, the low-salinity high-temperature Norwegian coastal water flowing in from south-west and by the low-salinity low-temperature Arctic water flowing in from the north. The water masses partly mix in the eastern and central area. A front area (the polar front) tends to form in the west, where the south-west flowing Arctic water meets the north-east flowing Atlantic water (Fig 4.3).

The northern part of the area is covered with ice for part of the year, reaching its maximum extent in early spring where it can extend into the central Barents Sea (74° N) Fig 4.1. The Barents Sea is a highly productive area with typical production rates of 165 g carbon per year per m<sup>2</sup> south of the polar front, and 115 g carbon per year per m<sup>2</sup> or lower north of the polar front depending of ice conditions. The pelagic production in the open water is much larger than the production under the ice. However, the marginal ice zone has a high, but much localised primary production and invertebrate production. While most of the primary production south of the polar front comes from a spring bloom, the production in the receding marginal ice zone may be looked upon as a continuous bloom.

### *Important seabird populations*

The Barents Sea has one of the world's highest seabird densities, with estimates of about 4 million seabirds in summer and 2 million seabirds in winter in the Norwegian part of the Barents Sea. There are many important seabird colonies and feeding areas as well as important moulting and wintering populations (Fig.4.4).

There are also large stocks of marine mammals. It is estimated that there are about 2 million seals, and that about 40,000 minke whales (*Balaenoptera acutorostrata*) forage in the area during summer.

### *Instability and high productivity*

From an ecological point of view, the Barents Sea is not isolated from areas further west and south. Many populations of fish, seabirds, and marine mammals migrate in and out of the area in seasonal and/or

life history cycles. The Barents Sea ecosystem has variations with periods of 3 years or more, mainly because of variation in the influx of Atlantic water. The variations cause a permanent situation of instability, because the predators never get adapted to the zooplankton populations before new variations occur. There is a growth in the populations with different growth rates, when there is influx of Atlantic water, and reductions when there is no influx. The instability is considered an inherent price for the high productivity in the area.

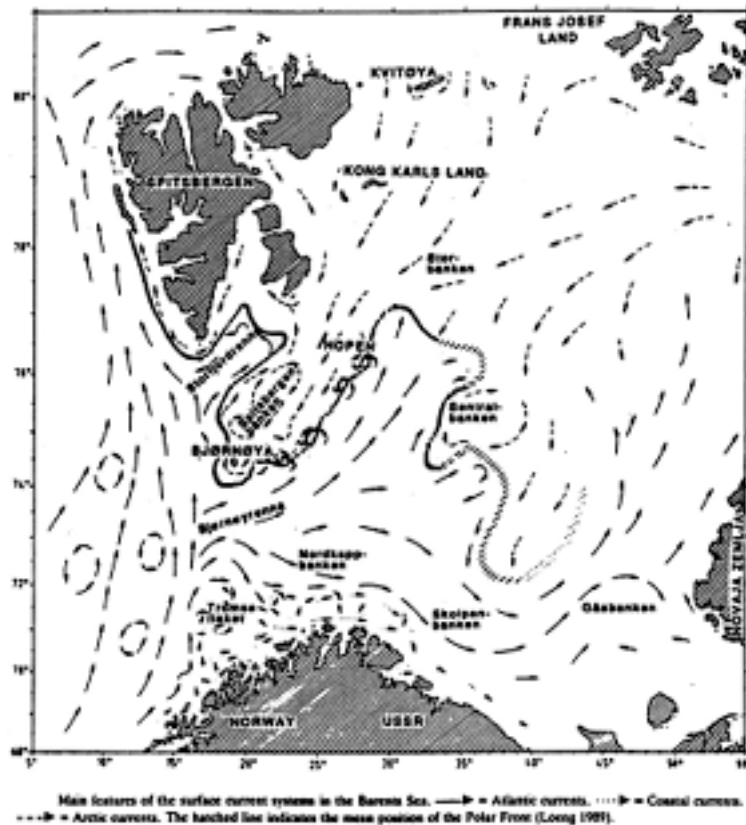

Figure 4.3. Main features of the surface current systems in the Barents Sea (from Loeng 1991).

#### *Keystone fish species*

The ecosystem has an inherent tendency to fluctuate between periods of strong recruitment of cod (*Gadus morhua*) and herring (*Clupea harengus*) with reduced size of the capelin (*Mallotus villosus*) stock, and periods of absence of herring in the Barents Sea, moderate recruitment to the cod stock and a large capelin stock (Gjørseter 1995). The ecosystem can maintain large stocks of pelagic fish to feed its predators including human being. The fishery takes more than 1 million tons of fish per year primarily capelin and cod. Fisheries certainly catch a large part of these pelagic fish stocks. However, it is suggested (Gjørseter 1995) that the most important effect of fisheries for the stocks is not the direct fishing mortality, but the enlargement of the instability in the whole ecosystem.

#### *Capelin stock crashed*

The instability of the lower levels of the system is cascading up the system. Capelin is a very important food item for cod, seabirds, seals, and whales and the productivity of capelin can vary with a factor of 20 between good and bad years. Low capelin levels certainly affect seals and food specialist like the large guillemots (*Uria* spp.). The



capelin stock crashed in 1985 by a combination of a number of years with bad reproduction, a large fishery and a growing cod stock preying on the capelin stock. After the crash in capelin stock, the guillemot (*Uria aalge*) had a number of years with few birds in the colonies and a very low reproduction, while the Brünnich's guillemot fared better using alternative prey (Vader et al. 1990). Without much knowledge on the long-term impact on the guillemot population, this certainly caused concern for the guillemot population, which is also reflected in the assessment of the potential impact of the oil activities.

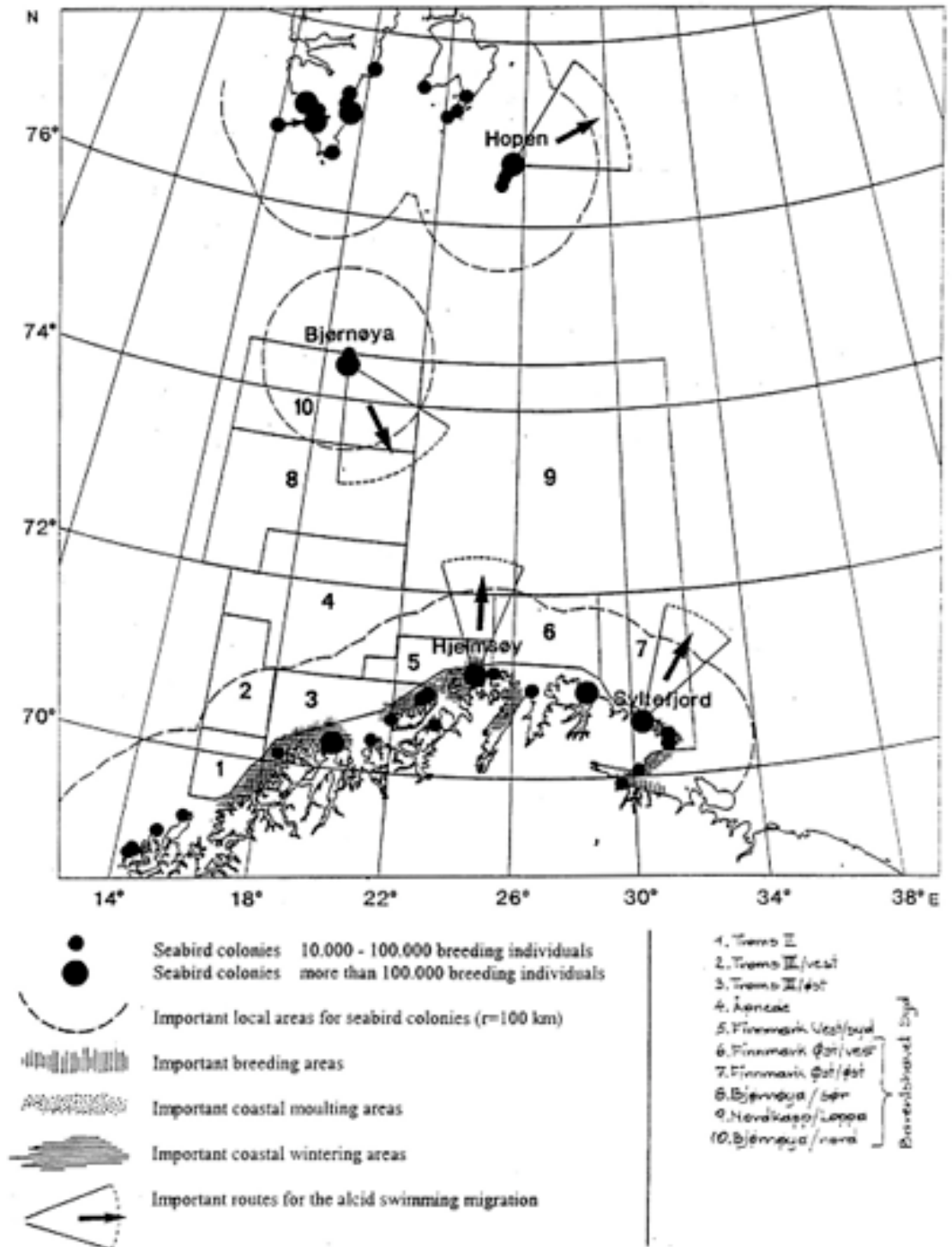

Figure 4.4. Important bird areas in the Barents Sea (from Børresen et. al. 1988).

## 4.2 The EIA document

*Published by Ministry of Oil and Energy*

An EIA on opening of the southern Barents Sea for petroleum activities was published in 1988 (Børresen et al.). It was the first EIA of petroleum activities on a larger shelf area in Norway as required in the law of petroleum activities from 1985. The EIA was a document of 91 pages with colour figures aimed at a large audience. An editorial board headed by a geophysicist from the Meteorological Institute wrote the document and were responsible for the conclusions. The report was financed and published by the Ministry for Oil and Energy (Olje- og energidepartementet) as official background information prior to the parliamentary debate on opening of the area. The EIA was circulated for comments, and formed the basis for the parliament's debate and opening of the area the following year.

*No public participation in the preparation*

The introduction to the EIA states the program background, legal framework for the EIA and refers to the scoping process. An interdepartmental working group with consultations to relevant institutions (but no public participation) had prepared the analysis and assessment program 3 years earlier. The working group (AKUP working group) consisted of representatives from ministries and their institutions (Ministry of Oil and Energy, Ministry of Fishery, Ministry of Environment and Ministries for culture, research, labour, and interior). The working group identified problems considered of special importance because either the potential impacts could be large or the impacts were considered important in relation to the political process in government and parliament.

The working group received project proposals from a number of institutions, mainly governmental applied research institutes. An example was a pre-project study (Prestrud 1986) from the Norwegian Polar Institute (NPI) identifying biological projects considered relevant based on basic principles of direct impact. The report substituted a previous account from NPI with a large number of more basic ecological projects, mainly extending ongoing research in ecological structure and function, which had been rejected by the AKUP working group. In the more focused account Prestrud (1986) stressed the need for better data on seabird numbers and distribution in the area and found the present data inadequate for an impact assessment (p. 34).

The working group distinguished between impacts from routine oil activities and impacts related to accidents. Routine operations include land use in relation to fisheries and disposal of waste. The regular disposal was regulated by pollution authorities and was not dealt with further.

**TABLE 4.1: Conclusions from the EIA-report (from Børresen et al. 1988)**

**“Conclusions**

*If all the above effects of oil activities are pulled together, two conclusions emerge, one concerned with space, the other with time.*

*It is possible to construct a picture showing the spatial distribution of the most vulnerable resources of the Barents Sea. Four zones can be identified:*

**1. The fish egg and larvae zone**

*This zone defines where the spawning products of the commercially important Arctic cod are present at vulnerable stages. It covers the southwestern part of the study area, i.a. south of Lat. 71° 30' and west of a line drawn from the North Cape to the Bear Island.*

**2. The coastal zone**

*The coastal zone covers the fishing banks where local fishermen get most of their catches, many very large colonies of sea birds, and adjacent feeding areas and many other vulnerable resources along the coast. The coastal zone can be described as a 20-50 km broad ribbon along the coast of Troms and Finmark.*

**3. The Arctic zone**

*The areas laying within 50 km off Bear Island and the constantly moving edge of the ice-floe constitute the Arctic zone, in which the bird colonies at Bear Island and the biologically productive edge of the ice-floe are the most vulnerable resources.*

**4. The open sea zone**

*The remaining part of the Barents Sea can be described as the open sea. Although many resources exist here, they are not as vulnerable as in the other zones.*

*Not all resources are equally vulnerable throughout the year. It is therefore possible to construct a picture in which time is the crucial factor.*

*The most vulnerable periods of the different resources are:*

- Cod eggs and larvae:           - mid March until mid May
- Seabirds nesting:           - April until August
- Seabirds moulting:         - mid July to mid October
- Seabirds wintering:       - November until March
- The coastal zone:           - all year
- Coastal fisheries:          - all year

*Generally speaking, no part of the Barents Sea should be exempted from oil activities on the basis of the information gathered and analysed in the present EIA-process. However, there is a case to argue that activities should be limited or carried out according to special procedures in certain areas or at certain times.*

*The purpose of oil exploration is to find, develop, and exploit oil in order to create an economic gain for companies and the state, and employment opportunities in various industrial sectors and regions. The search for oil in the Barents Sea has the potential to achieve this. There are, however, risks involved. Although the probability is very small, the possibility of an oil blow-out must be accounted for. If the activities are planned in such a way that due respect is paid to the presence of vulnerable resources in certain areas at certain times, the potentially harmful effects of oil activities can be greatly reduced.”*

### *Focus on oil blow-outs*

Focus was put on an oil blow-out as the accident that potentially could cause the largest environmental impact. A number of projects were initiated to form the background for assessing the potential impact of an oil blow-out. The projects included a compilation of existing relevant knowledge, filling basic data gaps on biological resources in the area (mainly numbers and distribution of animals) and development of appropriate assessment methods.

More than 30 projects were carried out at a cost of about 20 million Norwegian Kroner.

Major projects initiated by the working group included studies of:

- The probability of an uncontrolled accidental oil-spill
- Oil spill behaviour and spill trajectories
- Distribution, abundance and oil sensitivity of fish eggs and larvae
- Distribution and abundance of seabirds
- Development of methods for assessing the potential impact of oil spills on seabirds

The projects and the participating institutions are listed in the EIA and the reported information and some of the conclusions have references to the project reports or other scientific literature. Some of the conclusions were, however, made by the editorial board and are not necessarily corresponding to conclusions in the background reports. The summary conclusion of the EIA exemplifies what the research programme had acquired, as well as how the research results were used in the assessment. Some values of importance in the assessment are apparent as well.

### *Identifying vulnerable resources in time and space*

The main conclusion of the summary is cited in Table 4.1. Apparently, the ecological research results are primarily used to identify the most vulnerable resources in time and space. In addition, it is argued that if this information is used in planning the oil activities the ecological risk can be greatly reduced. The impact of a large spill is quantitatively estimated for fish but not for birds and mammals in the assessment. For fish two worst case situations were analysed one concerning eggs and the other the larvae. It was concluded that *“If a major oil spill coincides with the concentrations of cod eggs, and the horizontal and vertical interference of eggs and oil particles are calculated, and estimated maximum of 10-15% of that years spawning products of cod can be killed”* (p. 87).

Although the impact was not quantitatively estimated for birds and mammals, the main conclusion of the EIA report was.. *“no part of the Barents Sea should be exempted from oil activities on the basis of the information gathered and analysed in the present EIA-process”* (p. 90)

### *Seabird data inadequate*

Birds are dealt with in 8 pages in the report referring that the AKUP study program included surveys of seabirds as well as the development of a method for assessing the impact of oil activities. It

was recognised, that although the bird data had been much improved, by the study program, the seabird populations in the area had not yet been adequately surveyed. It had to a large extent been necessary to base the oil/ seabirds' assessments on “best professional judgements”. It is stated (p.46) that lack of important biological data made it impossible to make realistic estimates of how many birds that would die or suffer sub-lethal damages because of an oil spill, and how long time the impacted populations would need for restitution. It was however considered possible to estimate the relative impact, so these could be compared between species and areas.

*Seabird assessment*

The bird/oil assessment included a description of the seabird fauna, identification of important seabird concentration areas and an assessment of the importance of the area for the seabird populations. The relative oil spill vulnerability for each sea-bird population was presented for autumn, winter, spring, and for breeding, non-breeding and moulting birds during summer (Table 4.2).

It is stated (p. 48) that “*regardless of season and spill area the risk of significant damages to important seabird populations if a spill occurs, must be assessed as substantial*”.

Table 4.2 Mean population vulnerability (Pv-index) for seabird populations in 14 systematic groups. \*= Low, \*\*=Moderate and \*\*\*=High Vulnerability. See text for description of the index.

Group	Summer-breeding	Summer Non-breeding	Moulting	Autumn	Winter	Spring
Cormorants	***			***	***	***
Diving ducks	***	***	***	***	***	***
Mergansers	***		***		***	
Alcids	***		***	***	***	***
Divers	**	***			***	***
Tubenoses (Fulmar)	**	**		***	***	
Gannets	**			*		
Geese	*			***		
Dabbling ducks	*		*		*	*
Phalaropes	*			*		
Skuas	*	**		*		*
Gulls	*			*	**	*
Terns	*			**		*
Swans					**	

Table 4.3 The potential long-term effect index (PL-index) for seabird populations in different seasons and subareas. 1=low, 2=moderate and 3 =severe effect. Two values separated by a “:” are given, they are based on the same index calculation (Anker-Nilssen et al. 1988, p.69) but scaled differently. The first figure is the scaling used by Børresen et al. in the EIA-report, followed by the scaling originally used by Anker-Nilssen et al. (see text for further explanation).

Subarea	Troms				Finmark			Bjørnøya sør	Nord- kapp	Bjørnøya nord	Total	No of Popula- tions
	1	2	3	4	5	6	7	8	9	10		
Season												
Summer	2:3	1:2	2:3	2:3	3:3	2:3	1:2	1:2	1:2	2:3	2:3	45
Moulting	1:3	1:2	1:2	1:2	1:2	2:3	3:3	1:2	2:2	2:3	2:2	21
Autumn	3:2	1:2	2:2	2:3	2:3	1:3	1:2	1:3	2:3	1:3	2:(3)	(37)
Winter	2:3	2:3	2:3	2:3	2:3	2:3	2:3	1:2	3:3	1:2	2:3	27
Spring	2:3	1:2	2:3	2:3	2:3	2:2	3:3	2:3	2:3	1:2	:(3)	(36)

### 4.3 The oil/bird background reports

A background report presents the full analysis of the potential impact of oil activities to seabirds in the southern Barents Sea (Anker-Nilssen et al. 1988). The report is based on a report describing the analytical method (Anker-Nilssen 1987) and two data reports presenting numbers and distribution of seabirds in the area (Bakken and Mehlum 1988, Strann and Vader 1988). The analytical method was developed as part of the EIA (AKUP project) and the data reports were mainly based on data collected in AKUP-projects.

#### *The oil-seabird analysis*

The background report presenting the oil-seabirds analysis was published after the EIA main report. It is remarkable that the authors in the preface to the background report (Anker-Nilssen et al. 1988) emphasise, that they do not approve of the way seabirds were treated in the main report. Their contributions had been changed without they had been consulted. In particular they disapproved of the presentation of the main conclusion of the impact analysis and refer to the conclusions in their own report. A comparison confirms that the conclusions in the seabird analysis had been changed in the main report. The seabird report recommended not to proceed with the planned oil activities:

#### *A different conclusion*

*“Regardless of area and season for the planned oil activities many populations of international conservation value will face the risk of very severe impacts in case of an oil spill. Populations with pelagic lifeform are most vulnerable. Several of these populations are already in bad shape for other reasons and are seriously decreasing. The situation is especially critical for guillemots (Uria aalge). Populations of this species can be further reduced in any events including a large oil spill.”* And the text continues (p.80) *“..with regard to seabird assessments the concern for this species*

*alone seems sufficiently important to recommend not to proceed with the planned oil activities”.*

*A different scaling*

Further, it was stated in the conclusion that there were large differences between sub-areas as to which season oil spills will do the most damage. Nevertheless, as much as 75 % of all the simulated oil spills would result in severe impacts for the seabirds. Anker-Nilssen had calculated index values for the potential long-term effect for seabird populations. To simplify the index-values they were reduced to tree levels; low, moderate and severe effects (Table 4.3). However, when presenting these results in the EIA-report Børresen et al. used another key to the tree levels of impact, which lowered the average level of expected impact considerable, (Table 4.3) generally from severe to moderate. I see this as a methodical error by Børresen et al., but is also an example of how sensitive the use of index values are to subjective interpretations.

*No quantitative estimates of mortality or recovery time*

In developing the analytical method it was apparent, that because of lack of knowledge of seabird biology (population structure and dynamics, behaviour in relation to oil slicks, restitution ability), it was impossible to make exact quantitative estimates of the impact of an oil spill. It was concluded that competent professional judgements would be a necessary part of oil/ seabird analysis a long time ahead.

The method developed does however go far using semi-quantitative index principles. Semi-quantitative index-models have been developed for oil spill vulnerability and potential impact within sub-areas. These make it possible to calculate the relative vulnerability of populations, in different seasons and sub-areas and thus make a relatively objective and standardised analysis. All seabirds regularly occurring in the area are included in the analysis.

Thus the analysis showed, e.g. that the southern area is more vulnerable than the northern, and the summer period is more vulnerable than the winter, and that alcids are the populations most vulnerable.

*Numbers and distribution data*

The input data on seabird numbers and distribution was collected using international standardised methods and included breeding bird, seabirds in the coastal zone and seabirds offshore.

Breeding bird surveys were conducted in the colonies as total counts of pairs or individuals and sample plots were marked as well for future studies of trends. Colonies of black guillemot (*Cephus grylle*) and little auk (*Alle alle*) breeding in scree (stone slide) could not be surveyed by direct methods and were not surveyed. Species not breeding in colonies were not surveyed either because of the limited resources.

In the coastal zone (less than 30-40 m depths or areas that could be surveyed from land) birds were surveyed as total counts (of each species) within small well-defined units. The survey platform was land, boat, helicopter or small airplane whatever was most convenient. The airborne survey platforms were only suited for few species and were mainly used for moulting and wintering sea-ducks

in larger shallow water areas. Larger flocks were often photographed for later counting.

Offshore seabird surveys were all transect studies measuring the density of the different species. Ship-based surveys were conducted using the international standardised method (Tasker et al. 1984) in a 100, 200 or 300 m transect depending of weather conditions. Aerial surveys generally were conducted as strip surveys (100 m on each side of the airplane) at a height of 60 m and a speed of 150 km/h.

#### *Poor offshore coverage*

Data on bird distribution and numbers was considered of good to moderate quality for colony surveys and moulting seabirds, while data quality generally was considered poor to moderate for migration and winter populations. In particular survey effort offshore in the Barents Sea was considered limited, compared with the size of the area, because of lack of funding. Furthermore, it was acknowledged that lack of understanding of the factors governing the offshore distribution of seabirds, hampered the possibilities for making generalisations and predicting seabird distributions. As did lack of knowledge on seabird behaviour and population dynamics. It is clearly stated in the oil /seabird analysis that this limited the validity of the analysis (Anker-Nilssen et al. 1988).

#### **Anker-Nilssens Impact analysis method**

Realising that with the present knowledge, it was impossible to do exact quantitative calculations of the impact of oil spills (Ford et al. 1982, Wiens et al. 1984), Anker-Nilssen (1987, et al. 1988) developed guidelines for a standardised oil/seabird impact analysis. He pointed out that since the use of a qualitative impact assessment resting on qualified assumptions is inevitable, it is important to standardise the procedure as far as possible. The main principle in his oil-seabird analysis-method is depicted in the flowchart (Fig. 4.5). Semi-quantitative models (index method) for calculating individual (Iv) and population (Pv) vulnerability indices are central in his guidelines (see Table 4.2 for results and Table 4.4 for the formulae).

#### *Vulnerability indices*

The seabird vulnerability index-model for the relative vulnerability, both for seabird populations and individuals, are independent of oil drift simulations. The model uses 9 vulnerability criteria on the individual level and 8 on the population level each scored on a 3 divided scale (low, moderate, and high). Each of the 17 vulnerability criteria is related to one of five vulnerability factors (Table 4.4 list the criteria and factors). For each population, separate indices are calculated for sub-areas and seasons). The criteria in the analysis describe relevant behaviour, reproduction strategy and population status. Assessing values for the different criteria and using a formula weighing the importance of the different criteria for individual and population vulnerability values, overall individual and population vulnerabilities can be calculated (Table 4.4).



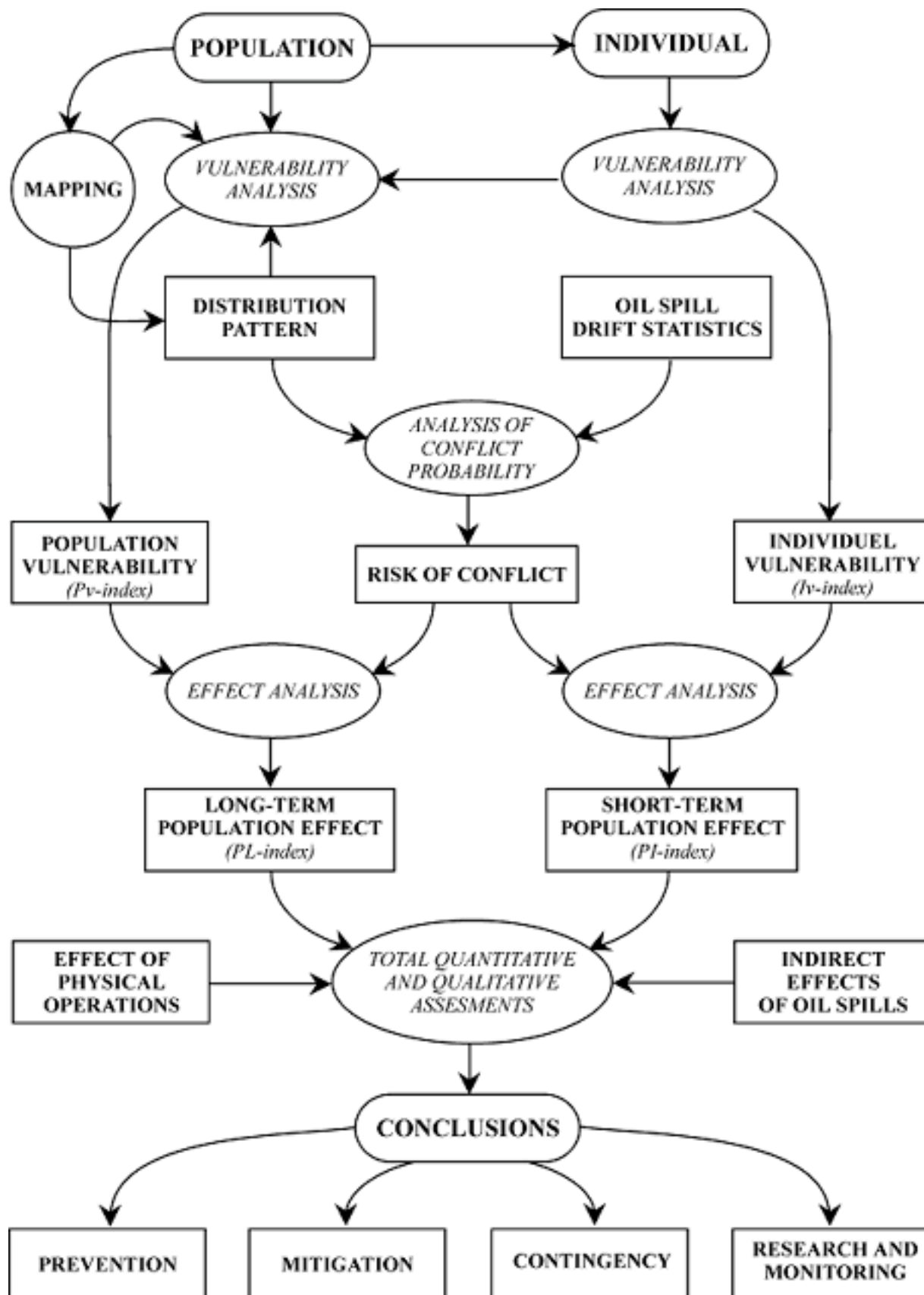

Figure 4.5 Schematic principles for the analysis and assessment system used for seabirds in the Barents Sea (translated from Anker-Nilssen et al. 1988). The analytical steps are depicted as elliptical.

**TABLE 4.4. Principles of the seabird vulnerability index model**

(Translated and summarised from Anker-Nilssen 1987).

The model gives relative vulnerability indices for seabirds, which during the year stays within defined oil spill risk areas. Separate indices are calculated for breeding, moulting, autumn migration, wintering and spring migration, for each species.

There are five vulnerability factors in the vulnerability index model:

$$\text{Vulnerability} = A * B * C * D * E$$

The vulnerability factors are defined:

<b>A</b>	Presence	<i>Time spent in area</i>
<b>B</b>	Surface-time	<i>Time spent at sea surface when in the area</i>
<b>C</b>	Exposure-risk	<i>Potential for oil contact when at sea surface</i>
<b>D</b>	Oil-damage	<i>Potential for damage if oil contact</i>
<b>E</b>	Damage-effect	<i>Potential for mortality or reduced reproduction if damaged</i>

Each of the five main factors is derived from one or several of 17 (9 individual level + 8 population level) vulnerability criteria:

Vulnerability Factor	Vulnerability criteria	
	Individual level	Population level
A Presence in area	Ta	-
B Surface-time	Ts	-
C Exposure-risk	Am, Ab, La	Ex
D Oil-damage	Rp, Fa	Pr, Fl
E Damage-effect	Fc, Re	Im, Rp, Pt, Vp, Pi

The nine individual level criteria are defined:

Ta	<i>time spent in area</i>
Ts	<i>time spent at sea surface per day</i>
Am	<i>area swept per time unit</i>
Ab	<i>behaviour at sea (e.g. swimming, diving, preening)</i>
La	<i>littoral affinity</i>
Rp	<i>reaction potential, environmental constraints to oil avoidance</i>
Fa	<i>flying ability</i>
Fc	<i>physical condition</i>
Re	<i>recovery, the individual potential for recovery in relation to feeding ecology</i>

The eight population level criteria are defined:

Ex	<i>population exposure potential due to distribution within the area</i>
Pr	<i>population size within the area in relation to other species</i>
Fl	<i>potential for concentration in flocks</i>
Im	<i>fraction of non-breeding immatures in the population</i>
Rp	<i>reproductive potential to substitute oil spill mortality (reproductive strategy)</i>
Pt	<i>population trend in the area</i>
Vp	<i>fraction of flyway population in the assessment area</i>
Pi	<i>potential for immigration to the area, to substitute oil spill mortality</i>

All the vulnerability criteria can have three values 1=low, 2=medium and 3=high.

Substituting the vulnerability factors (A\*B\*C\*D\*E) with the relevant expressions using vulnerability criteria and weighing factors the formula for the individual vulnerability is:

**Individual vulnerability:**  $Iv = Ta * Ts * 2(Am+Ab+2La)/5 * (Rp+4Fa)/5 * (Fc+Re)/2$

The individual vulnerability (Iv) is a factor at the population level vulnerability (Pv), while the vulnerability factors A and B only relates to the individual level. Thus substituting the vulnerability factors (Iv\*C\*D\*E), the formula for the population vulnerability is:

**Population vulnerability:**  $Pv = Iv * Ex * (Pr+2Fl)/3 * (2Im+4Rp+2Pt+4Vp+Pi)/13$

The resultant vulnerability index scores are finally normalised on a 3 divided scale (low, moderate high) based on the cumulative probability distribution of all possible values of Iv and Pv.

---

To assess the potential effect (impact), the vulnerability index score is multiplied with an oil drift “conflict index” score.

**Vulnerability index \* Conflict index = Effect index**

The conflict index score is calculated using a grid with 30x30 km cells. It is the risk of an oil spill entering a cell (calculated from oil spill drift simulations) multiplied by the proportion of the seabird population present in the cell (calculated from the numbers and distribution database). Since both the conflict index score and the vulnerability index score are indices, the resultant impact score is also an index. Using the individual vulnerability index score in the calculation, the impact score gives a relative value for the immediate effects of an oil spill, while using the population vulnerability score gives a relative value for the more relevant long-term impact (PL-index , Table 4.3).

#### *Conservation value*

As a help to identify, national as well as international important bird populations in the assessment area, Anker-Nilssen (1987) has developed conservation value categories. The conservation value is defined using a principle of comparing the population size in the assessment area with the corresponding national and international population size, weighted with a restitution capacity factor for the population. If the population in the area constitutes more than 2.5 % (for species with low fecundity), 5 % (for species with medium fecundity) or 10 % (for species with high fecundity) of the international population it is considered of international importance (I). If the population in the area is more than 5 % (for species with low fecundity) 10 % (for species with medium fecundity) or 20 % (for species with high fecundity) of the national population is it considered of national importance (N).

## 4.4 The fate of the EIA-report

The Norwegian parliament opened The Barents Sea for oil exploration in 1989 based on a document from the Ministry for Oil and Energy (OED) recommending it (Stortingsmelding nr. 40, 1988-89, Åpning af Barentshavet Syd for Letevirksamhet, Olje- og Energidepartementet. 143 pp.). The document summarises the EIA-report (Børresen et al. 1988) and the comments received from counties, scientific and governmental institutions, as well as NGO's (Fishery organisations and the Nature Conservation Society). In the summary of the evaluation of the EIA-report the OED state that " *From some research fields/environments the EIA-report have been criticised, while the background research has been positively evaluated*" (p 23). The OED states that they have recognised the critique and emphasised the direct use of the background reports in the document to the Parliament. The OED specifically asked the Parliament to use the conclusions in the oil/seabird analysis report, instead of the EIA-report. The OED had included statements of insufficient data, from several of the background study teams in the material to the Parliament.

Important comments from the hearing in relation to ecological knowledge, with focus on the bird/oil issue, presented in the EIA report can be summarised as follows:

### *Report biased*

The Ministry of Environment (Miljøverndepartementet) based its comments on input from its institutions: State Pollution Control Authority (Statens forurensningstilsyn), Directorate for Nature Management (Direktoratet for naturforvaltning) and Norwegian Polar Institute (Norsk Polarinstitutt). The institutions all evaluated the EIA report as being biased, and partly incorrect in the presentation of the results from the biological background reports, and emphasised important data gaps in the knowledge base. Clearly, although the institutions were represented in the AKUP- group, their views and opinions are not expressed to their satisfaction in the EIA-report.

The Directorate for Nature Management (DN) did the bird assessment at their research institute Norsk Institutt for Naturforskning (NINA). They put forward the critique expressed by Anker-Nilssen et al. in the seabird assessment referred earlier.

### *Further research needed*

The Norwegian Polar Institute put forward the most radical recommendation not to open the assessment area for the time being. The institute emphasised the special conditions in the Barents Sea making oil activities more risky than further south. Furthermore, the lack of data and knowledge, especially in relation to oil and the biological conditions in the ice, and to marine mammals and seabird populations were underlined. The institute assessed that 5 more years with data sampling and research was necessary before the area should be opened for oil activities.

### *No-go areas*

The Ministry of Environment expressed the overall opinion of the environmental department. They found that a number of areas and periods should be closed for oil exploration. That the operators should use special oil spill measures to protect bird populations both coastal and offshore, and that comprehensive environmental monitoring programs should be conducted if activities should be initiated in the area.

Furthermore, The Ministry of Environment made a statement, which potentially could overrule the EIA document and its conclusions: “*it should as soon as possible be evaluated whether further research are necessary to make the EIA complete and comply with the legal provisions in Petroleumsloven.*” It appears that the responsible Ministry for Oil and Energy (OED) addressed this by responding in the comments that the best available knowledge had been put forward.

The Ministry of Environment summarised a number of special environmental features that should have emphasis in the assessment:

- Lack of knowledge of the interaction between oil and ice, and the biological resources in the ice. At the same time the marginal ice zone is probably the most important in the Barents Sea with ice-fauna, ice-flora, seabirds, polar bears and marine mammals vulnerable to oil spills.
- Seabirds have important ecological functions and are very vulnerable to oil spills.
- Unique conservation value bordering one of the earth’s last wilderness areas- the polar area.
- The ecological system in the Barents Sea is already stressed making it susceptible to larger environmental impacts from petroleum activities than normally.

The Ministry of Environment referred to the principle for EIA in the UN/ECE convention, at that time under development, and found that future EIAs should comply with these principles. Further, The Ministry of Environment found that in the future a better method for EIA, which better could describe the overall impact of petroleum activity, should be developed and used. In relation to the Barents Sea North a comprehensive environmental programs should be developed as part of an EIA for this area.

The governor of Svalbard and the Fylkesmanen in Finnmark (Northern Norway) both mentioned the critical ecological situation in the Barents Sea for fisheries and seabirds. The need for further research before initiating new activities that could have a negative impact was emphasised.

#### **Other scientific institutions**

From ProMare, the Norwegian Arctic marine ecology program, comments were also received. The natural ecological instability in the area was emphasised and therefore it was concluded that the assessment of the impact of oil activities would necessarily be very imprecise. How much the potential impacts should be discussed was

#### *Imprecise assessment*

then an open question, a matter of assessment, as it was stated, when precise conclusions would not be possible anyway. The ecology of the marginal ice zone and the process of oil sedimentation were mentioned as topics, which could have been discussed in further detail.

#### *Lack of worst case scenario*

Senter for Industriforskning had themselves “*developed a simulation model for the impact of oil on birds before it became clear that the Environmental Ministry would do the job*”. They stated in their comment that their results for oil spill impact on birds were in accordance with the EIA-report. However, they lacked a statistical estimate of environmental damage and an assessment of damage in a worst case scenario combined with a statistical estimate of the probability for the worst case. Furthermore, the institution made a basic comment to the contents of the EIA-report. If the purpose of an EIA was to analyse and present knowledge so politicians can decide what is important and what is not, two different components in the EIA were considered important. First, a description of actual impacts anticipated, with the uncertainty in the current knowledge, secondly subjective assessments. Senter for Industriforskning found that the two kinds of information were not clearly separated in the IEA. For example, the use of relative impact categories was mentioned (e.g. the categorisation in small, medium and large impacts used by Anker-Nilssen). It was found to obliterate the overall impression of the potential impact. The argument was that large impacts in aquaculture could not be compared with large impacts in seabirds without going back to the definitions. I interpret this comment as a wish for a more quantitative risk prediction, supplemented by qualitative subjective assessments. Anker-Nilssens method (1987) actually produces rather objective indices for vulnerability and impact (see p. 54 and Table 4.4). However, the indices are relative to limit the uncertainty in the predictions. The crude categories are not more subjective than exact predictions based on a large number of best guess parameter-values would be. The uncertainty is just limited (because results are only relative) and made visible in the crudeness of the categories. The drawback of the index categories is that they are more abstract than a number for dead birds and recovery times.

#### **Comments from others**

#### *Satisfaction*

Local political parties, community councils, and labour and business organisations expressed generally satisfaction with the EIA-report. In their opinion, environmental concerns could and should be addressed properly, and petroleum activities should proceed in the area. Fishery organisations were much more sceptical and some did not want the area opened while others emphasised a need for further research and no-go areas for the oil industry.

The oil company's organisation (Norsk Industriforening for Oljeselskap), and Statoil emphasised that significant seabird damages mostly would occur if an oil spill reached the coast. Statoil found, that this was not clearly enough reflected in the EIA-report. They indicated that the oil spill risk analysis and trajectory should be seen more in relation to the probability of impacting vulnerable areas. I

interpret the comment as a wish for a more quantitative risk assessment.

*No confidence*

The Nature Conservation Society (Norges Naturvernforbund) was apparently the only environmental group that had the report mailed for comments. They returned the report and stated that they had no confidence in the EIA-report, based on the comments from Anker-Nilssen. The Nature Conservation Society demanded a new independent and competent analysis.

## **4.5 Conclusion on the Barents Sea EIA of oil and seabirds**

The assessment of the potential impact of oil spills on seabirds in the Barents Sea is based on a detailed and well-described method, which includes detailed vulnerability and impact index-models. However, information on distribution and numbers is inadequate for offshore areas and there is a need for further studies on seabirds population dynamics and behaviour in relation to oil slicks.

The index-models for vulnerability include a large number of semi-quantitative parameters influencing the vulnerability. The models identify all the known important factors in the process and combine them to a single score for individual or population vulnerability. There is however sparse information available for assigning weight and values to the different factors. It seems though that reliable relative index-values for vulnerability of individuals, populations, and areas are calculated. The models seem to be good analytical tools for discussing potential mechanism of impacts, but they appear more complex than necessary in the actual assessment of potential impact taking into account the lack of data and understanding of the dynamics. However, the complexity in the models allows for a rather standardised approach which used with care can produce more objective assessments.

The mapping of relative vulnerability is important for mitigation and regulation to take special precautions in the most vulnerable period and areas.

It appears however, from the EIA-report and the comments received, that there are two problems with the relative method used. Firstly, the final result (index-value) may look as a more subjective judgement, than a corresponding exact estimate would do (see comment from Senter for Industriforskning). In addition the index-values seems to be easier to manipulate as done in the example in the table in the EIA-report (see Table 4.3).

Another problem with the relative seabird assessment method is that it makes it more abstract to discuss accept criteria. The lack of scenarios with quantitative estimates (or educated guesses) of population impacts, how imprecise they might be, take the focus away from the discussion of whether the oil activity is an acceptable environmental risk. Consequently, in the EIA-report conclusion the risk is accepted without criteria for acceptance have been specified

and discussed at all. In the conclusion, it is stated that certain areas and periods are more vulnerable than others, and the risk can be minimised using this information. However, it is concluded that no part of the Barents Sea should be generally exempted from oil activities based on the information in the EIA. The economic gain to society of the oil activities makes it only a discussion of preventive and mitigative measures.



## 5 The Beaufort Sea Case

### 5.1 Ecological presentation

*Low productivity and harsh ice conditions*

The Beaufort Sea is an Arctic marine area characterised by low temperature, low productivity, and harsh ice conditions. The sea ice begins to melt and break up in mid-June and start freezing mid-September, however with large inter-annual variation in timing. During winters most of the nearshore water less than 2 m freezes to the bottom. Landfast ice, stabilised by grounded ridges, extends seaward to approximately 15-30 m depth, where there is a shear zone with the pack ice. The ice protects the shallow sediment coastline, where there is mud and silt to 30 m depth and barrier islands, lagoons and shoals. There is only a small water intrusion (water mixed with water of Pacific origin) past point Barrow from the Chuckti Sea to the Beaufort Sea (Fig 5.1). A large terrestrial freshwater runoff in spring creates an estuarine environment on the Beaufort shelf (AMAP 1997). The freshwater runoff is an important source of organic particles for the system and is utilised by benthic crustaceans in the coastal zone. The large freshwater runoff also increases the melting and breaking up of sea-ice and stabilises water layers. In May ice algae primary production is higher than the pelagic primary production, although overall it is smaller. The ice algae's production is however considered important because it is providing an input early in the season.

*Polar cod a keystone species*

The polar cod (*Boreogadus saida*) is very important both in the pelagic and in the ice-related food webs in the Beaufort Sea (Fig. 5.2, the US name Arctic cod is used for the polar cod on the figure). It has been described to be the key species in the ecosystem in the Arctic Ocean and may influence the distribution of marine mammals and seabirds, because it is important prey. Anadromous fish species like Arctic char (*Salvelinus alpinus*) and whitefish (*Coregonus* spp.) that spawn in freshwater and migrate seaward as juvenile and adults, are important in coastal and brackish water where they feed during the open water season. During the 3-4 month open water season they accumulate energy reserves for spawning and wintering.

*Birds mainly May-September*

The marine bird fauna consists of migratory birds using the area in a short intense period from May to September, and only black guillemots (*Cepphus grylle*) can be found during winter. It has been estimated that each spring 800,000 king eiders (*Somateria spectabilis*) and 130,000 common eiders (*Somateria mollissima*) migrated past Point Barrow into the Beaufort Sea following the shore-leads along the coast (Johnson and Herter 1989).

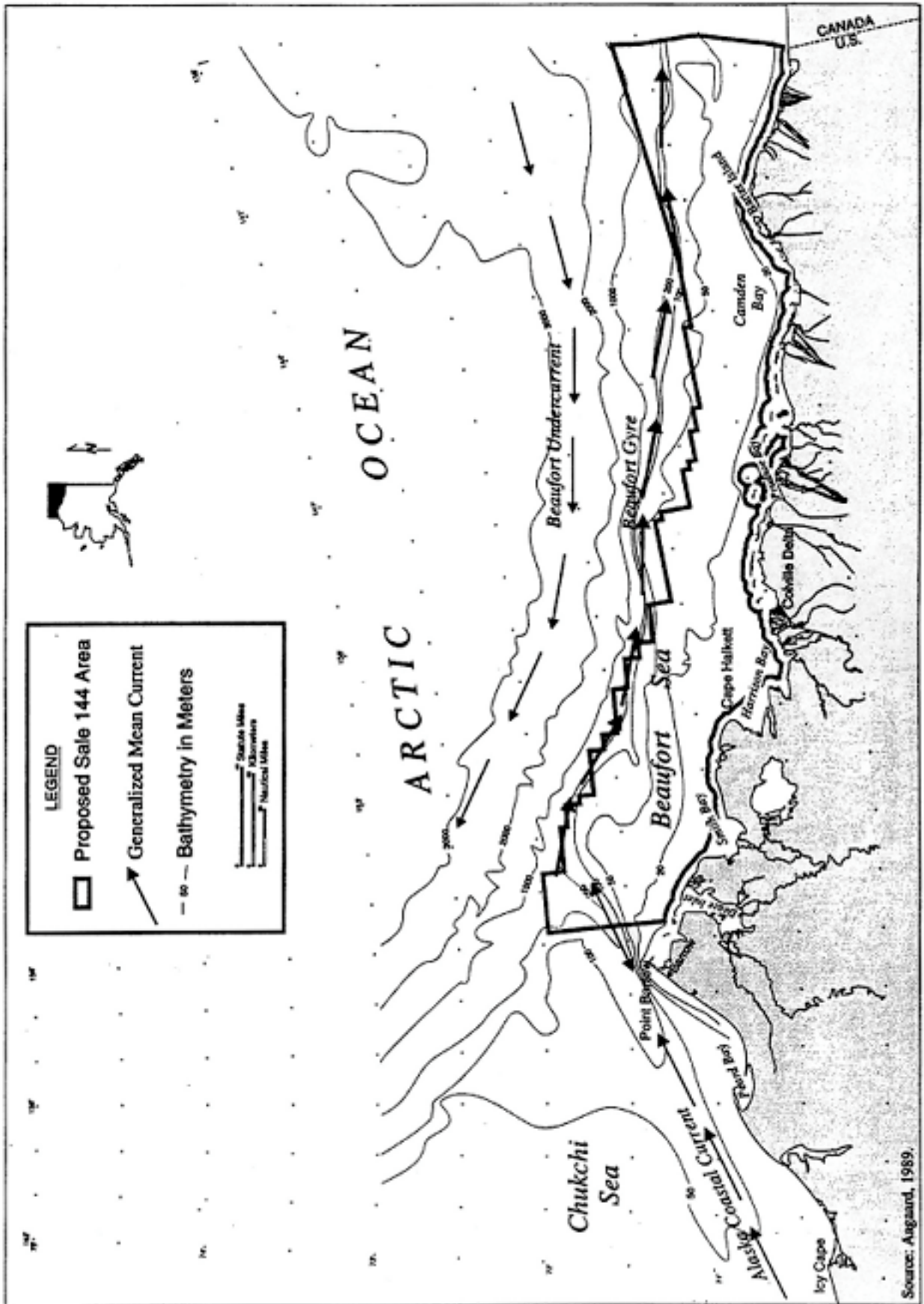

Fig 5.1 (From MMS 1996).

Generalized Schematic of the Offshore Circulation in the Beaufort Sea

*Small seabird colonies -  
large coastal seaduck  
concentrations*

The most important habitats in the Beaufort Sea for water- and shorebirds are the nearshore, lagoon and littoral zones (Fig. 5.3). This is in contrast to other areas in Alaska where the pelagic environment supports the major portion of avian biomass (National Research Council 1994). In the offshore waters, the glaucous gull (*Larus hyperboreus*) is the main contributor to avian biomass. Common birds at the shoreline include red phalarope (*Phalaropus fulicaria*), glaucous gull and common eider. Bird colonies in the area are small, there is thus no bird colony with more than thousand birds. The lack of significant numbers of nesting seabirds along Beaufort Sea coast is most likely the result of the lack of nesting sites, that afford protection from terrestrial predators such as Arctic foxes (*Alopex lagopus*) and grizzly bears (*Ursus arctos*). Oldsquaws (*Clangula hyemalis*) nesting areas are inland on tundra and marshlands, where they breed rather dispersed. However beginning in mid July large concentrations of 10,000 to 50,000 of oldsquaw, and eider (*Somateria* spp.) possibly totalling several hundred thousands occur in coastal waters and inshore of the barrier islands. They arrive from inland breeding areas and breeding areas further to the east, respectively. In the coastal waters the birds feed intensively and moult before fall migration. There is a subsistence harvest of approximately 5,000 eiders (all species), harvested mainly at Barrow.

Ringed seals (*Phoca hispida*) occur widespread and dispersed in the area. It is the most abundant marine mammal with a winter population estimated to 40,000 and a summer population estimated to 80,000. In the western part of the area walrus (*Odobenus rosmarus*) from the north Pacific population occur. White whales (*Delphinapterus leucas*) migrate through the area to summer in the Mackenzie delta and an important population of bowhead whales (*Balaena mysticetus*) migrates through to feeding areas in the eastern Beaufort Sea.

There are approximately 10,000 inhabitants living along the coast of the Beaufort Sea.

*Extensive environmental  
studies*

Since the initial discovery of oil and gas along the coast of the Alaska Beaufort Sea in 1968 there has been exploration and development in the area. The most important is the Prudhoe Oil field, one of the largest in North America. Along with the development of oil and gas resources, there has been concern for and interest in wildlife resources in the area. It was estimated in 1989 (Johnson and Herter 1989), that over the previous 20 years at least 300 million dollars had been spent on baseline studies, environmental impact statements and monitoring programs for birds, mammals, fish and their environments in and near the Alaska and Canadian portions of the Beaufort Sea. Research programs have been both government and industry sponsored. For the Alaskan Beaufort Sea the U.S. government sponsored "Alaskan Outer Continental Shelf Environmental Studies Program" has made significant contributions. Research results and reviews (e.g. Johnson and Herter 1989) have to a large extent been published in the scientific literature and are

summarised in the extensive environmental assessments, on which this description is based (MMS 1984, 1990, 1995, 1996).

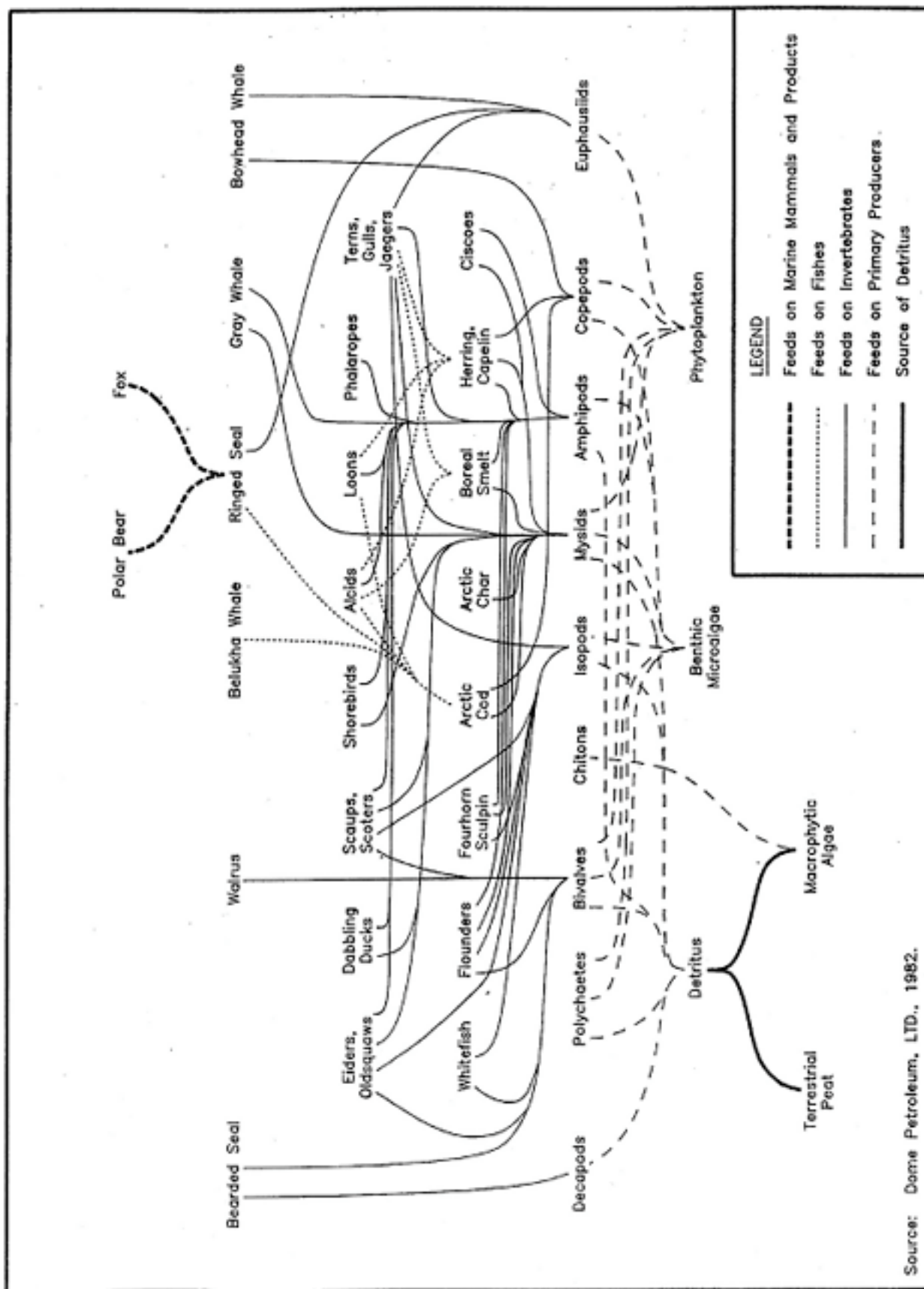

Figure 5.2 (from MMS 1990).

## 5.2 The EIA document

### *A 2.3 kg EIS*

In USA, an EIA report called a Draft Environmental Impact Statement (DEIS) is published for public and institutional comments and then a final version responding to the various comments is published. The Draft Environmental Impact Statement for the Beaufort Sea Planning Area, Oil and Gas Lease Sale 144 was published in August 1995 in a comprehensive paperback volume (1,7 kg). This report refer to earlier EIS reports from the area (MMS 1984, 1990).

The Final Environmental Impact Statement (FEIS) for the Beaufort Sea Planning Area was published in two volumes in 1996. It is not continuously paginated, but total weight is 2.3 kg including a 165-page review and analysis of comments received.

### *Written and published by MMS*

The documents were written and published by the Minerals Management Service (MMS) Alaska Outer Continental Shelf Region, under the U.S. Department of Interior, and were written in co-operation with the U.S. Environmental Protection Agency. It was an official document representing the opinion of the institution, however 25 contributing authors and supporting staff members are listed in the end. The documents were the results of an extensive environmental assessment process (summarised in Appendix 3). It was part of the pre-lease activities culminating in a final decision by the Secretary of the Interior, on whether to open the area and hold the lease, and if so under what terms and conditions. The FEIS was thus part of the background material for this decision, and a branch of the Secretary of Interiors administration wrote it.

The document described the purpose (to meet national energy demands) and background of the proposed opening of the area for oil and gas development, and alternatives to the proposed opening. It included the descriptions of the affected environment and the potential environmental effects of the proposed action and the alternatives. Proposed mitigation measures and their potential effect were also analysed in addition to potential cumulative effects resulting from the proposed activities. Background information and method descriptions were included in appendices.

### *Four alternatives assessed*

It is a significant feature of the EIS that four alternatives were analysed: the proposed lease sale, a no sale alternative and two alternatives with deferrals for areas that could reduce the effects on subsistence resources, particularly the bowhead whale. One of the alternatives with deferral was particularly requested by a local community.

### *Use action scenarios*

Another significant feature of the EIS is the analysis of action scenarios. A key component is the analysis of effects associated with hypothetical oil spills that could be associated with the different lease alternatives and a cumulative case. For each of the alternatives, three scenarios were developed assuming that high, base and low levels of petroleum resources respectively were discovered and exploited. The

cumulative analysis considered environmental effects expected to result from the incremental effect of the lease sale when added to all past, present and reasonable foreseeable future human activities, including both other lease sales and non-oil activities.

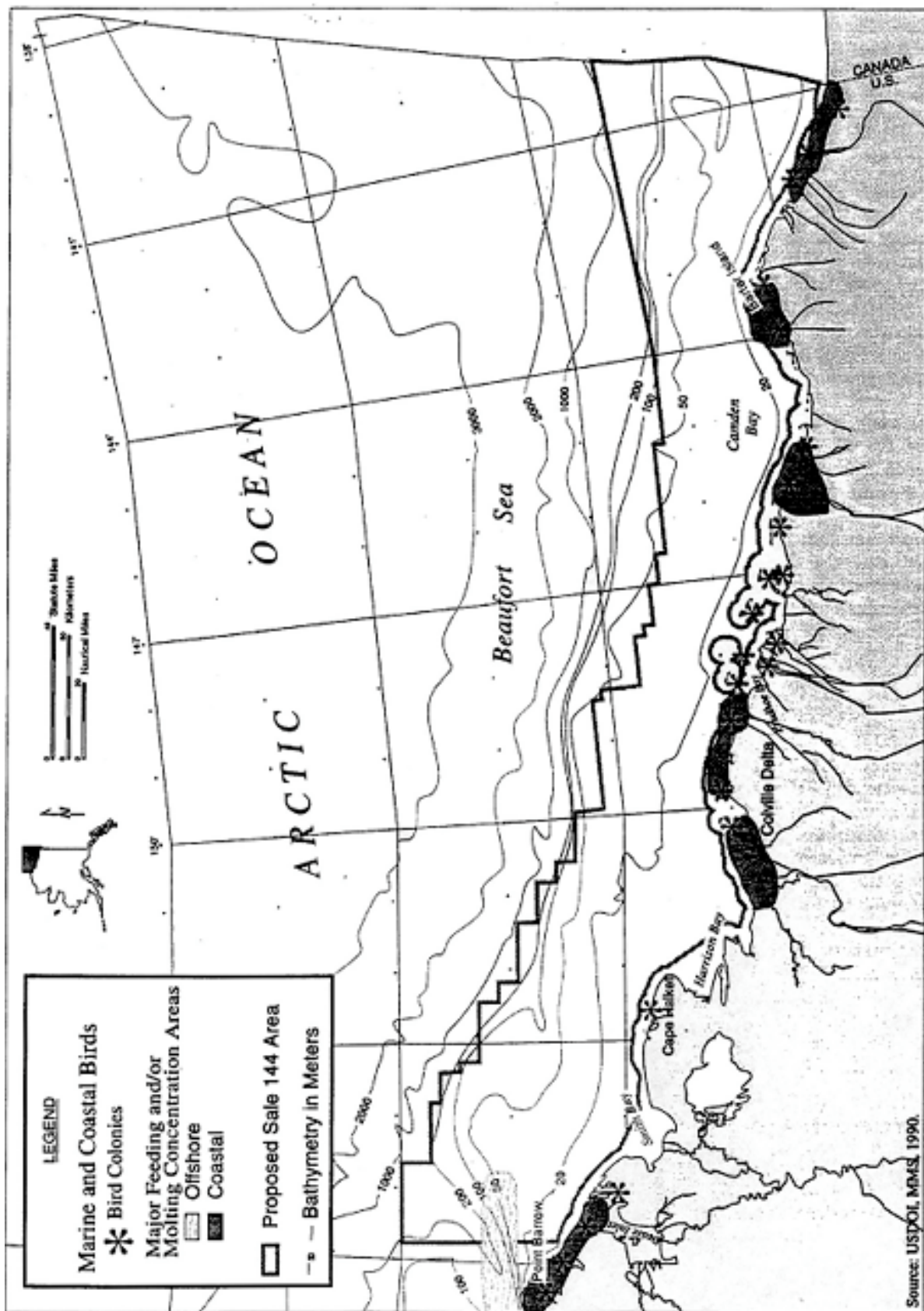

Figure 5.3 (from MMS 1996).

The significant resources and activities to be analysed in the EIS were determined in the scoping process. During scoping the MMS made contact with other Federal and State Agencies, the public, academia, and environmental groups to identify those resources about which there was concern. Specific resources and activities determined to warrant an environmental analysis, included the following: water and air quality; lower trophic-level organisms; fishes; marine and coastal birds; pinnepeds, polar bears and white whales; endangered and threatened species; caribou; the local economy in the coastal area; socio-cultural systems; subsistence harvest patterns; archaeological resources; and land use plans and coastal management programs.

The general summary of impacts resulting from the proposed oil activities is given in Table 5.1.

Table 5.1. Summary of Effects on Biological Resources (cited from MMS 1996 vol. I p.v). (Bird effects highlighted by author).

*“Overall, the activities associated with the base case are expected to affect a very small portion of some of the populations of biological resources in the area. Each of the two assumed oil spills is expected to have lethal and sub-lethal effects on up to two percent of the lower trophic level organisms, which include the phytoplankton, zooplankton, benthic, and epontic (living on the underside of sea-ice) communities for a period of less than 7 years. Fisheries effects are expected for a small portion of some populations consisting of several generations. **Effects to marine and coastal birds may consist of habitat alteration and the loss of several thousand birds to oil contamination, but recovery is expected within one generation (2-3 years).** Small numbers of pinnipeds, polar bears, and white whales may be affected, with recovery within one generation (2-5 years). Bowhead whales exposed to noise producing activities and oil spills could experience temporary sublethal effects; however, oil spills could result in lethal effects to a few individuals, with the population recovering within 1 to 3 years. **Effects to spectacled and Steller’s eider are expected to be minimal, affecting <2 percent of the population; however, mortality from an oil spill is expected to require up to two generations for recovery.** Effects to caribou are expected to include displacement within 1 to 2 km along the pipeline and roads for more than one generation and perhaps over the life of the proposal, but these disturbances are not expected to affect caribou migration and overall distribution.”*

*Estimates of mortality and recovery times*

It can be seen from the summary conclusion that the impact on birds and other biota is assessed in crude estimates of absolute numbers or fractions of the population. Population recovery is estimated in generations and years.

In the 1990 Beaufort Sea EIS the summary of effects was tabulated and values (low to very high) assigned to different levels of impact, where the 1996 EIS is more descriptive.

### 5.3 Beaufort Sea bird data in the assessment

In the Final EIS is a brief description of marine and coastal birds in the area based on a previous EIS (MMS 1984) augmented by additional material. It is mainly papers and reports from NOAA's Outer Continental Shelf Environmental Assessment Program (OCSEAP) (e.g. Divoky 1984, Connors 1984 and Frost and Lowry 1984) a book reviewing Birds in the Beaufort Sea (Johnson and Herter 1989) and other papers and background reports to which references are given. However the analysis of the potential impacts is included in the EIS itself, in contrast to the Barents Sea case.

There appears to be good knowledge of location of major bird concentrations as well as the total or maximum numbers of birds observed in the concentration areas. Important coastal habitats and bird colonies are mapped. For offshore areas, maximum densities are given and for a number of species estimates for the total number in or passing the area are given. Figures for bird numbers or densities are generally given as minimum, maximum or intervals.

#### *Endangered species*

Endangered and threatened species had been identified and put on the official List of endangered and threatened species according to the "Endangered Species Act of 1973" by Fish and Wildlife Service (FWS). The act defines an endangered species as a species in danger of extinction throughout all or a significant portion of its range, and a threatened species as one that is likely to become endangered within the foreseeable future. Spectacled eider (*Somateria fischeri*) and Steller's eider (*Polysticta stelleri*) were given a special consideration, because they were listed as threatened, and proposed candidate, respectively. The Arctic subspecies of the peregrine falcon (*Falco peregrinus tundrius*) had recently been removed from the list, but was under special observation.

Eiders have recently received panarctic attention by the Circumpolar Seabird Working Group because of generally declining populations (CAFF 1997)

#### *Spectacled eiders*

Declines in the spectacled eiders small breeding population had been reported throughout its breeding range, but relatively high nesting success suggested that the population decline was caused by factors operating outside the nesting period. It breeds scattered along the Beaufort coast sometimes far inland. When departing from the breeding area both sexes stage in nearshore coastal waters for 1-2 weeks prior to moving west and south. Birds in this phase characteristically concentrate in few large flocks. Following coastal staging, post-breeding males have been located in coastal Beaufort Sea. While most spectacled eiders moult further south on the way to the wintering area, which has been located in the Bering Sea. Spring migration proceeds mainly along inland routes.

#### *Steller's eiders*

Steller's eiders are coastal migrants through the western Beaufort. Recent population estimates range from 2,000 to 7,000 in north-western Alaska, which is a small part of the estimated holarctic population of 150,000 -200,000 birds. However there is an estimated 50 % decline in the holarctic population since the early 1970's.



## 5.4 Assessing the effects of oil spill on marine and coastal birds

### The scenario approach

The basic tool in the assessment of the potential impact of oil spills was the Oil Spill Risk Analysis (OSRA) which estimated the probability of oil pollution in different areas in different oil development scenarios. The principle in OSRA is:

- 1) For a development scenario, the probability for oil spills in different size categories are calculated based on historical oil spill statistics.
- 2) Based on oil spill trajectory modelling the conditional probability of an oil spill contacting a coastal segment or another environmental sensitive area is calculated.
- 3) Based on 1) and 2) the combined probability of oil-spill occurrence and contact with different environmentally sensitive areas can be calculated. However, the OSRA-model-trajectory results are appropriate only for spills > 1000 barrels (159 m<sup>3</sup>).

In the oil-/bird analysis the combined probability for one or more oil spills > 1000 barrels occurring and contacting important habitats had been calculated in the OSRA. Based on these combined probabilities and knowledge of bird numbers and densities at the different localities the direct loss of birds due to one or more oil spill was crudely estimated (Fig. 5.4). The species most likely to experience the losses were identified based on numbers and distribution, how concentrated they occur and how much time they spend on the sea surface. The estimates of losses were however based on crude judgements, and the fact that oil contact is usually fatal. Indirect losses due to local reduction and contamination of available food sources were also taken into account. The estimation of direct losses was thus done with professional judgements, in contrast to the modelling of the probability of oil contacting the habitat.

### *Long-term effects*

The long-term population impacts were expressed as the recovery time for the affected populations and were estimated in generations and/or years. This estimation was also done as professional judgements using knowledge of the species breeding biology and the status of the population. This assessment was done for the most abundant species, and specifically for species identified as endangered and threatened (spectacled eider and Steller's eider).

For the base case scenario it was estimated that the most likely number of spills during the lifetime of the development would be two (combined platform and pipeline). The most likely size of the spills would be 7,000 bbl (1,100 m<sup>3</sup>) each.

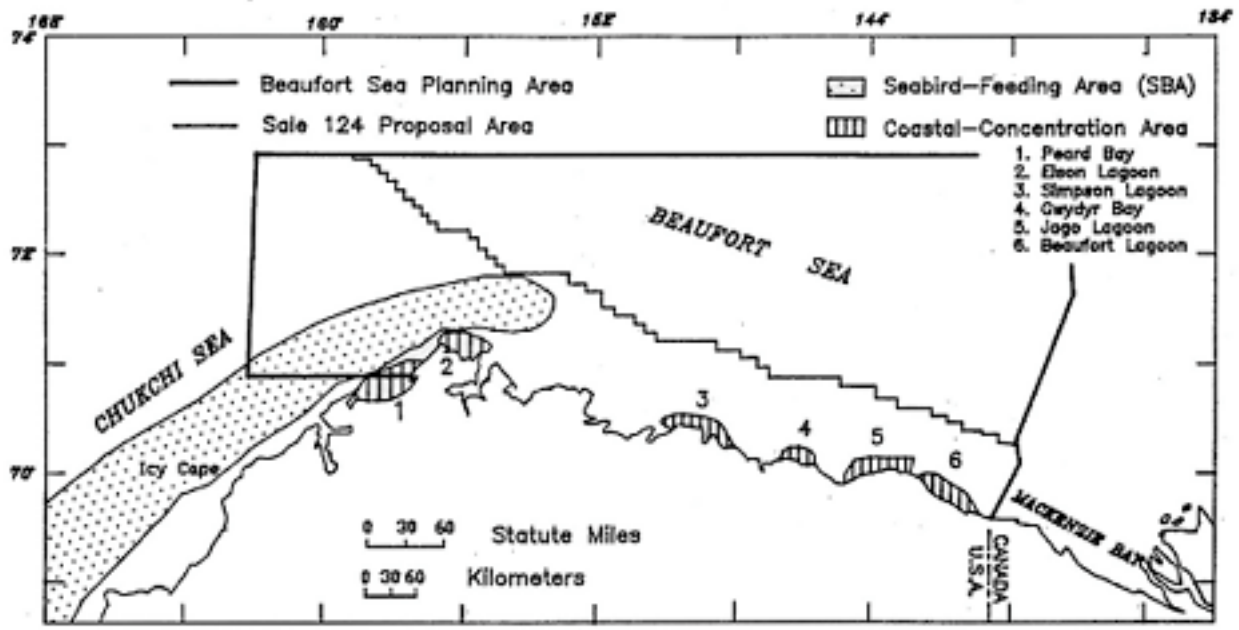

COMBINED-PROBABILITY SCALE

SBA AND COASTAL-CONCENTRATION AREAS

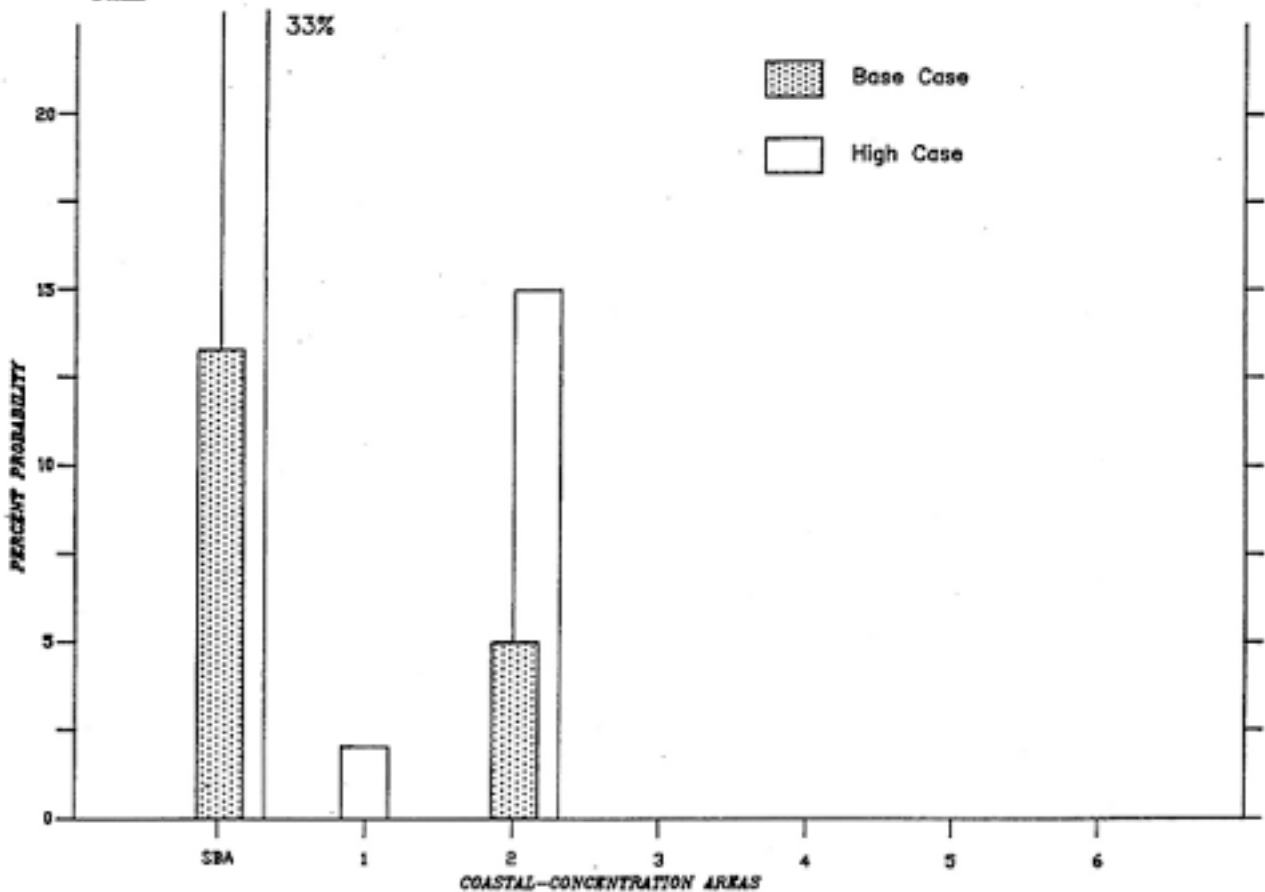

Combined Probabilities of Oil-Spill Occurrence and Contact of Seabird-Feeding and Coastal-Concentration Areas--Base and High Cases

(Combined probabilities of one or more oil spills occurring and contacting SBA and Coastal-Concentration Areas during the open-water season within 30 days over the production life of the lease area.) Taken from OSRA , Appendix G, Table G-17.

Figure 5.4. Combined probabilities of of oil spill occurence and contact of important seabird areas (from MMS 1990).

It was concluded that the effects of oil spill on marine and coastal birds were expected to include the loss of several thousand to perhaps 10,000 sea ducks (primarily oldsquaw). In addition, a number of seabirds would suffer losses with expected recovery of populations within 1 generation (about 2-3 years).

The environmental impact of five alternatives to the base case was assessed in the EIS. Apart from the base case scenario (Alternative 1 - The Proposal) the impact were also assessed of the “no lease sale Alternative” (no local impact), of two different reduced lease sales the “Barter Island deferral alternative” and the “Nuiqsut Deferral Alternative”, of a “Low Case” scenario, where only exploration would take place (6 exploratory wells drilled) and no recoverable oil would be found within the lease area; and of larger oil development in the lease area the “High Case” where it was assumed that 3,900 Mmbbl ( $620 \cdot 10^6 \text{ m}^3$ ) of oil would be produced from 25 platforms and transported to shore through 224 km of pipelines (while in the base case analysis it was assumed that 1,200 Mmbbl ( $191 \cdot 10^6 \text{ m}^3$ ) of oil would be produced from 8 platforms and transported to shore through 50 km of pipelines). In these alternatives the most likely number of oil spills  $> 1,000 \text{ bbl}$  ( $159 \text{ m}^3$ ) increase from 0 in the low through 2 in the base case to 6 in the high case. These most likely numbers of oil spills were used in the scenario’s combined with a spill size of 7,000 bbl ( $1,100 \text{ m}^3$ ), which were the average size of spills more than 1,000 bbl ( $159 \text{ m}^3$ ).

The effect on coastal and marine birds from oil spills in the scenarios vary. In the low case scenarios no oil spills were expected, while in the high case “*significant increase in spill occurrence and contact probabilities indicates that a larger portion of one or more of the 6 spills would contact important habitats and probably a much larger number of birds*”.. than in the base case.

### **The worst case scenario**

#### *A 25,000 m<sup>3</sup> pipeline spill*

A realistic worst case scenario for a large oil spill called “effects of low-probability, high-effects, very large oil-spill event” were developed. This was a scenario for a 160,000 bbl ( $25,000 \text{ m}^3$ ) pipeline spill corresponding to the largest spill on the (US) outer continental shelf that had occurred since 1964. The spill results from a pipeline leak caused by a deep keel on an old multi-year ice ridge during a November storm. The leak is not detected until July the following summer, a week after ice break-up. Within 30 days, from the spill is released from the sea ice, over 480 km of shoreline would be oiled and spill contact could result in the loss of more than 10,000 waterfowl and shorebirds with predominant mortality among common species such as oldsquaw and common eider.

Contamination of coastal habitats was expected to have effect on the suitability of these wetlands to some waterfowl populations for 1-2 generations. The oil spill would also sweep the important seabird foraging area offshore of Point Barrow - Northern Lead System during summer. Using the average density of 38 bird/km<sup>2</sup> in this habitat, it was estimated that at least 53,000 birds could be contacted and killed.

*Recovery in 2-6 years*

It was concluded that the total “*effects of a very large oil spill on marine and coastal birds are expected to include the loss of tens of thousands to over 100,000 birds, with recovery of populations taking about 1 to 2 generations (2-6 years).*”

For the threatened spectacled eider (and the candidate: Steller’s eider) relatively low mortality was expected (<200 each). Because brood-rearing takes place in tundra pond habitat most of the oil would have transformed to tar-balls, before most females with juveniles entered the marine environment. It is therefore concluded that “*overall oil-spill effects on the spectacled and Steller’s eider are expected to be minimal, affecting <2% of the population; however recovery from mortality resulting from a large oil spill is not expected to occur if population status is declining as at present.*”

## **5.5 The case of the spectacled eider - an undetected risk**

The assessment of the potential impact on the spectacled eider population will be described in more detail. It is interesting both because in the first assessment in 1990 the spectacled eider was overlooked, and because in the next EIA the small declining population was not adequately impact assessed.

*Overlooked*

In the 1990 Final EIA spectacled and Steller’s eider was not listed as threatened, and therefore not assessed separately. They were not mentioned in the general treatment, which were phrased very much like the 95-96 EIS. It concluded “*Species (such as murrelets (large guillemots (Uria spp.)) or auklets) with low reproductive rates or species with low population levels are not likely to suffer high mortality as a result of an oil spill occurring in the Beaufort Sea, since large guillemots (Uria spp.) and auklets (Aethia spp.) are not abundant in the sale area and loon (Gavia spp.) populations are not concentrated*”.

With the knowledge from the 1995-6 EIS, where spectacled eider is listed as a threatened species and a detailed analysis is carried out, it appears that here is really a species where the local population could suffer a devastating loss because of oil spills. While the populations of more abundant species are expected to recover within few years. Since the spectacled eider has been declining for the past 20 years, it must also have been vulnerable in 1990 - where it was not even mentioned in the EIS. It was not identified in the analysis because there were no focus on small populations and population status unless the species were listed as endangered or threatened. I consider this a lack in the analysis and it stresses the need for information on population status for small populations.

*Can the population recover from an oil spill?*

In the draft EIS (MMS 95) it was concluded that: “*relatively low spectacled eider mortality is expected from an oil spill (<100 individuals); however recovery from spill related losses may require as much as two generations in view of their declining numbers on the breeding grounds in recent decades and their relatively low reproductive rate*”.

In response to this the Fish and Wildlife Service (FWS) wrote (letter included in Final EIS 1996 vol. 2, V15):

*" The various development cases under the proposed alternative all predict oil spills and lethal impacts to spectacled eiders. Predicted recovery times from these spill-related losses vary from 2 to four generations. As long as the spectacled eider population continues to decline, it is difficult to perceive how the population could recover from any additional mortality. Only under the cumulative case (IV G) is the uncertainty of population recovery from oil spills relative to the overall decline of the population even mentioned."*

and the MMS responded (final EIS 1996 vol. 2, V17):

*" ; if substantial numbers are lost, recovery in the near future is not likely under present circumstances. The analysis has been revised to reflect the uncertainty of this species situation "* And for the spectacled eider it was concluded in the Final EIS (MMS 96): *" that relatively low oil spill mortality is expected (<100 individuals); but unless mortality is near the lower end of this range (<e.g., 25) recovery from spill related losses is not expected to occur if population status is declining as at present "*.

The central point in this discussion is that *" As long as the spectacled eider population continues to decline, it is difficult to perceive how the population could recover from any additional mortality "*. Strictly speaking, recover in the assessment could only be expected to be that the population recovers to the previous rate of decline. However, since we do not know the reason for the decline, we do not know if the mortalities are additive. Furthermore, we do not know, if there is a threshold under which, the population in the area will crash. In a declining population there is theoretically no lower limit to oil spill mortality from where the population can be expected to recover quickly to previous numbers. There is just the reasoning that very small mortalities will be insignificant compared to natural variability in survival and productivity. I think that this case illustrates that it is impossible to assess the resiliency to oil spill mortality of a small declining population, unless there is an understanding of the population dynamics and the reason for the decline.

## **5.6 Other Comments to the Draft and Final EIS**

### *Local desire for expanded input*

During the comments period for the Draft EIS public hearings were held in three local communities and in Anchorage. The EIS staff analyst responded to 151 separate comments derived from written submissions and 68 comments from oral testimony. Most of the written comments (73) where from native organisations and communities and many were from federal agencies (44). The comments from native organisations and individuals were almost entirely in opposition to the proposed lease sale. The primary issues raised (relating to the scientific input) addressed the following concerns, 1) a local desire for expanded input into the design of monitoring studies and the formulation of exploration plans, 2) the belief that MMS consistently underestimated the effect of underwater noise on the behaviour patterns of migrating bowhead whales, 3) the

perceived failure by MMS to incorporate indigenous “traditional knowledge” within the analysis of the effects of the proposal and 4) the inability of industry to clean up a spill in ice-pack conditions.

#### *Bowhead whales*

The local comments generally reflected a feeling that their knowledge was not fully used and reflected in the document, and they feared that the activities could threaten their way of life. In the marine area primarily effects on the harvest of marine mammals and especially the bowhead whales were a concern. It was a concern that bowhead whales can be impacted by underwater noise from seismic activities, and by oil spills, and that there would be inability to clean up an oil spill during periods of ice.

Apart from the MMS respond to the comments, changes were made in the Final EIS reflecting new information and some of the comments especially on subsistence harvest, “traditional knowledge” and new ITL’s (Information To Lessees) on community participation in monitoring and operations planning. ITL’s provides the lease operator with notice of special concerns and is considered a mitigation measure, however advisory in nature.

The Marine Mammal Commission opposed the assessment of recovery times for bowhead whales after an oil spill, very much parallel to the spectacled eider case. “*These conclusions may be valid however the DEIS does not provide data, analyses, or references to support all of them. For example, it is not clear how the stated recovery times were determined without information on the natural history and population dynamics of the various species. Without such information it is not possible to judge if the estimated recovery times are reasonable.*” The Marine Mammal Commission also found that there was a lack of consideration of indirect effects through important food items and feeding areas. And availability for subsistence uses was not adequately addressed. The MMS responded with more information given in the Final EIS.

#### *Inadequate information*

Lack of or inadequate information was a common comment to the DEIS, and it was put forward even stronger in an EIS for similar area (extending west past Point Barrow) in 1990. Here the Northern Alaska Environmental Center (an environmental group) compares with a report to the presidents OCS taskForce: “The Adequacy of Environmental Information for Outer Continental Shelf oil and Gas decision: Florida and California”. The report concluded concerning these areas “*available scientific and technical information is currently inadequate for development and production*”. Since the Beaufort Sea is considered the least understood offshore area in the nation, the Northern Alaska Environmental Centre concludes that there is simply not enough research and information available to go forward with the lease sale.

As far I can see in the documents there is a general public concern that the information is inadequate. However, specific questions raised, relates mainly to impacts on Inuit harvest and potential impacts on seabirds are not in focus.

## 5.7 The National Research Council information assessment

To help provide a scientific basis for evaluating the environmental concerns, and especially the amount of information available, the U.S. House of Representatives in 1991 requested that the MMS seeked advice from the National Research Council (NRC). NRC should assess the adequacy of scientific and technical information relevant to the potential environmental consequences of three Alaskan lease sales, one of them the Beaufort Sea (1990 DEIS). The NRC was further asked to consider other options than conducting additional studies in case information was inadequate in any respect. The NRC should however not consider whether oil and gas activities should take place in the area.

NRC put together a scientific committee who made a peer reviewed study: Environmental Information for Outer Continental Shelf Oil and Gas Decision in Alaska (National Research Council 1994).

*“information adequately reflects differences”*

The NRC study concluded that in general the information available for biotic resources and oil spills is adequate for leasing and exploration decisions. It adequately reflects the differences between Arctic OCS (Outer Continental Shelf) and other US OCS areas, where development and production have already occurred. However, concerning adequate information for decisions regarding development, production, transportation and siting of onshore and offshore facilities, it was concluded that site-specific studies of biotic resources will be necessary; Especially of marine mammals critical to the subsistence economy of Alaska natives. The site-specific studies should be carried out when exploration has determined the proper sites for these studies.

In reaching this conclusion the committee recognised the activities *“present a variety of risks to the biological and human environment and that even with sometimes sketchy knowledge, bounds could be put on the extend of those risks. Whether or not to accept the risks is a policy issue , not a scientific question.”*

*Need for more local involvement*

NRC regarded oil spills and interference (disturbance) with marine mammals, especially the bowhead whale critical to the subsistence economy of Alaska natives, to be the most controversial of the potential effects of OCS development in the Arctic OCS. The NRC concluded that *“these issues must be dealt with and Alaska natives and their experts should be substantially involved, otherwise plans to develop Arctic OCS oil and gas resources could be seriously jeopardised.” (p.188)*

In dealing with possible alternatives to additional studies in relation to matters of controversy, the NRC focused on the traditional rather centralised approach of facility siting (locate areas for industrial facilities). The NRC found that this approach was more or less also the paradigm established in the Environmental Studies Program and the OCS oil and gas leasing process. The traditional approach to facility siting was to use scientific methods to evaluate possible sites with a view towards potential impacts - most often through the EIS process- and to employ technical knowledge for avoiding or reducing

them. Using this approach, the MMS had not yet developed a decision-making process that was broadly acceptable in communities in northern Alaska. An alternative approach aiming at arriving at a co-operative solution would require establishing the basis for trust among the parties. Three considerations for establishing trust were listed: 1) A good track record of experience. 2) Decisions must be based on a process that is viewed as sound, fair and acceptable to all parties. 3) The community must have real control (play an active part) over decisions that influence risk.

The NRC committee had learned that the MMS program in Alaska has “a serious credibility deficit, whether or not its environmental studies are credible in an objective sense” (p.191). One important factor here was the experience of the Exxon Valdez oil spill. Alaska residents remembered repeated assertions of safety and preparedness before the spill in contrast to what they experienced during the spill. The NRC stated that it would just not be possible to prevent all impacts from large spills. The limitations in ability to respond immediately and completely successfully to a major accident should be acknowledged to increase credibility.

*From general descriptive studies to focused long-term studies*

MMS Environmental Studies Program was found to have yielded credible information useful for establishing a general baseline or characterisation of the living resources. The committee advised that the MMS should now concentrate on fewer, longer term studies of the living resources (with peer review of results) to develop the additional information needed for decision making about oil and gas production, transportation and development.

I find the spectacled eider is an example of this need for a change in focus from general descriptive to specific in-depth studies. The spectacled eider problem should have been identified during the general baseline studies of the living resources. After that, it should have been selected as a hot issue (or Valued ecosystem Component). Then in-depth studies should have been initiated which can give information on the population dynamic of the population and the cause of decline.

### **The National Research Council on bird information**

In general the committee concluded that information on biological systems is adequate to make informed decisions about whether to hold lease sales in the Beaufort Sea or not. For the later stages of the OCS activities, the committee has grouped the needed information in the categories: **adequate**; **questions remain** information is lacking but it is possible to indicate what information is needed and how to obtain it; **not feasible to obtain** so little is known about the system that the committee cannot identify what needs to be known ; **and unknowable** either the information is fundamentally impossible to know or the amount of work and time required to develop the information is far beyond any reasonable expectation (Table 5.2).

All major bird colonies at the coast of the Beaufort Sea had been identified and mapped and rough estimates of their sizes were available. Although in most cases the data were insufficient to



provide baselines against which to measure change (or assess damage from an oil spill), the data were considered sufficient to determine the approximate sizes of the populations at risk. Data on the distribution and abundance of breeding loons, grebes, waterfowl and shorebirds were considered less precise. But these data were probably sufficient in most areas for estimating the numbers of birds that could be exposed to an oil spill where these birds assemble after breeding.

Table 5.2 NRC (1994) assessment\* of quality and availability of biological information relating to birds for decision making (risk evaluation); and status of knowledge of where populations are concentrated, and how to do remediation if a resource is damaged (adapted from NRC 1994 Table 5.1-5.4).

Habitat	Risk evaluation		Concentrations (Hot spots)	How to do remediation
	Exploration.	Production, transport		
Open water	Adequate	questions remain	questions remain	adequate
Near shore	Adequate	Adequate	adequate	questions remain
Estuaries, lagoons	Adequate	Adequate	adequate	questions remain
Leads, polynias	Adequate	questions remain	questions remain	adequate
Fast ice	Adequate	Adequate	adequate	adequate

\*Assessments are based on current information and may change with new information and technology and : “should not be regarded as final judgements, because it is impossible to know exactly what information is needed until the size nature and location of the oil and gas resources are known” (p.115).

*Offshore information scattered*

Information on the pelagic distribution of marine birds was found to be scattered. However, knowledge of the species of birds and those birds' preferences led NRC “to anticipate that no large or important aggregation of birds occur in the offshore waters of the Beaufort. The data are therefore adequate for leasing and exploration decisions but should be augmented before development and production.” (p.100).

*Undersampling in potential staging areas*

The nearshore waters, particularly the coastal lagoons, were considered critical to the migrating waterfowl, as were their shorelines for shorebirds. Visits to these lagoons by large numbers of birds often are very brief- but still of critical importance - and it seemed possible to NRC that there were unrecorded significant concentrations. Thus additional studies of remote lagoon systems were warranted before development begins. A recently “discovered” staging ground for (black) brant (*Branta bernicla*) was cited as an illustrative example of the problems of under-sampling and of inadequate communication with the people living in and knowing the area. Given the generally sparse sampling effort, the range of variation was unknown and the lack of data on temporal patterns of use was considered most acute in areas where the major portion of a species population could occur.

Although published information on avian use of the lead system in the area was sparse, it was considered sufficient for judgements to be made about the importance of the lead system to birds. However,

under-sampling was considered a particular problem for the lead system in early spring and for the ice edge and pack ice in the late summer and early fall. Further surveys were considered necessary to identify the concentration areas.

*Data insufficient to specific recovery predictions*

Some basic ecological knowledge on food habits and reproduction were available. However, NRC found the data insufficient to construct life tables, to predict how birds would respond to major shifts in the environment, and to predict how their population ecology would change after a major loss of individuals. Indeed the NRC committee concluded that although MMS has the charge to predict environmental impacts and the recovery of ecosystems the committee: “*acknowledges the impracticality of attempting to gather enough data for MMS to provide more than generalised understanding and predictions of responses of populations to major losses*”(p. 103). “*For the most part it is unlikely to prove practical to obtain enough information for precise predictions of long-term responses and recovery times. The task of obtaining the required information is too immense.*” (p. 105). Concerning remediation and restoration – part of the task that the congress charged MMS in it's Environmental Studies Program- the committee concluded that “*in many cases the difficulty and expense in trying to obtain sufficient information would be excessive*” and “*in some cases beyond current abilities*”.(p.121)

Here the NRC actually concluded that not only was data insufficient to precisely predict impact of oil spills on bird populations, it would also generally be impractical to obtain necessary information for more than generalised predictions. I agree with this conclusion based on my review in chapter in chapter 3. However, for me this acknowledgement underlines the importance of focusing on adaptive management, where the oil spill risk is seen as one among several factors in the management of the species. This is especially important for species where an extra mortality from oil spills could make a significant difference. Thus, research should be focused to support this adaptive management.

Another point in this connection is the importance of communicating this acknowledged uncertainty in seabird impact predictions. This uncertainty could in my opinion have been more clearly communicated in the Beaufort Sea EIS.

## **5.8 Conclusion on the Beaufort Sea EIS for seabirds**

The assessment of the potential impact of oil spills on seabirds in the Beaufort Sea includes both estimates of mortality and recovery time for the population. The rough estimation of mortality seems reasonable given the data available. The estimates of recovery times are however flawed by lack of essential specific information on population trend and status, making these estimates unreliable. It was not clearly explained how the estimates were made. It is necessary with quite detailed ecological information on a population to assess to which degree the oil spill mortality is additive. The uncertainties, especially of the recovery estimates, were not clearly stated.

On the other hand the quantitative estimate of mortality and recovery times provides a good basis for discussions of accept criteria.

The focus in the assessment is on the most numerous species and the species listed as endangered. It appears from the example with the spectacled eider that this approach is too narrow. It is also necessary to select species in the near-endangered range for analysis, in fact all species should be screened for special problems.

The impact assessment received a large number of comments. Two government agencies (Fish and Wildlife Service and Marine Mammal Commission) questioned the method for estimation of population recovery times, and many citizens had a lack of confidence in the assessment and felt their local knowledge had not been incorporated. Thus the impact assessment was successful in creating debate, but it did not achieve general confidence.

## 6 Discussion

It is important to realise that EIA-reports (EIS) are not scientific documents, but science and scientific research are important factors in the assessment. This is reflected in the document, sometimes to a degree where the integrity and esteem of science tends to hide value-based judgements, which might be misconceived as “scientific facts”. Analysing the role of ecological science in environmental impact assessments I distinguish between two levels of evaluation; the internal scientific level and the broader cultural and policy framework level. At the internal scientific level the question is can/does ecological science deliver scientifically based answers to the questions raised in EIA ? The question at the policy level is how are the answers used and what questions are raised with the expectation to get a scientific based answer ? Here special attention is given to the communication of (the inevitable) uncertainty.

Here scientific means a method for producing knowledge following scientific rules and practices. The discrimination between the internal scientific process and the policy process is of course a simplification. Even the scientific process is influenced by a number of value judgements as discussed below.

### 6.1 The internal scientific perspective

In chapter 3 is the scientific background for predicting the impact on bird populations of a large oil spill described. It is shown how our understanding of the dynamic of the system only allows for very broad statements on potential impacts. Studies of actual spill effects have contributed significantly to assess the range of potential impacts, although our limited understanding of the ecosystem dynamics even confounds studies of effects after actual spills.

*It is not possible to predict the exact impact reliably*

In the two EIA cases analysed in chapter 4 and 5 descriptions of possible impacts of bird populations are given. With a relatively limited knowledge of distribution, population sizes and general ecology of the species, the most sensitive areas and periods have been identified mainly based on relative methods. It is much more problematic to make quantitative predictions of the impact of an oil spill on bird populations, because detailed knowledge on the dynamic of the specific population is needed. In the Barents Sea case the biologists abstain from exact predictions of impacts on populations. They use vulnerability and impact indexes and conclude that there can be severe impacts. In contrast, the Beaufort Sea case contains estimates of both mortality and recovery but without clearly stating the vague background for the estimate and the associated uncertainty. In the end it is not scientific predictions based on a detailed understanding of the system, but best professional judgement incorporating the resilience experienced after large oil spill in other marine systems.

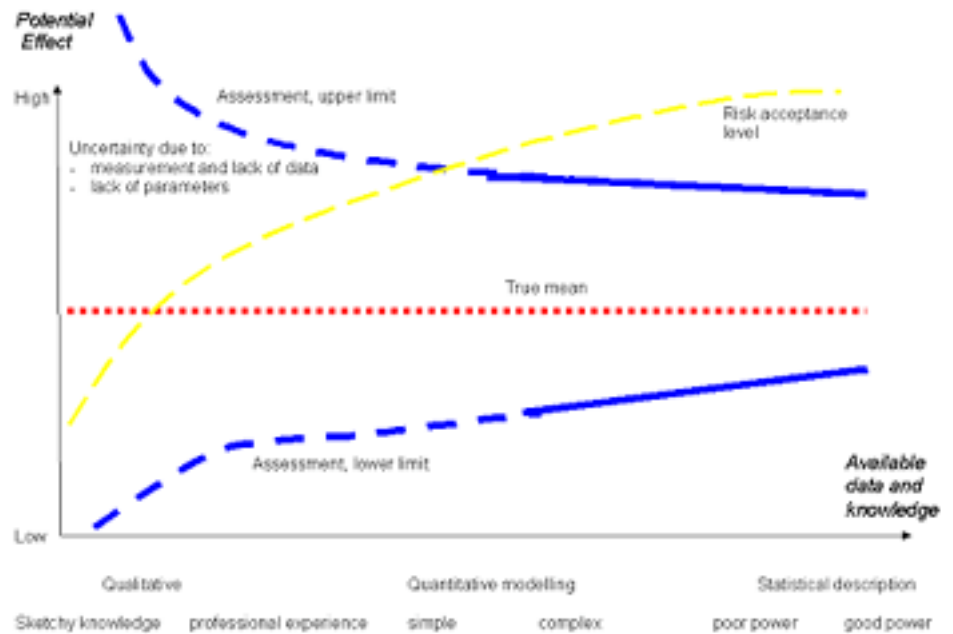

Figure 6.1. Generalised relation between assessment of effect and true effect at different levels of knowledge. Bold curves represent assessment of maximum and minimum effect. Improved understanding of system dynamics can give better system models and reduce the "natural" variance. The grey curve represents the public risk acceptance level (see text for further explanation).

### Categories of uncertainty

The uncertainty in scientific statements on potential ecological effects can be categorised in three forms (Holling et al. 1978, O’Riordan and Jordan 1995):

- 1 Uncertainty as data unavailability
- 2 Uncertainty as ignorance. Limited understanding of the dynamics in nature due to its complex nature, unknown thresholds for non-linear ecological reactions can occur.
- 3 Uncertainty as indeterminacy. For certain questions we lack data, parameters and complexity is so great that modelling becomes a lottery

You may say that we lack either 1) data 2) parameters and/or 3) models.

In figure 6.1 I have made a sketch of the generalised relation between assessment of effect and true effect at different levels of knowledge. The true effect can never be deterministically predicted without uncertainty, there is an inherent natural stochasticity. However, the assessment can converge towards the true mean as data and model is improved. The mean of the true effect is the dotted horizontal line. The uncertainty of the assessment is the space between the bold lines, consisting of uncertainty due to sampling errors and lack of data, and uncertainty due to lack of significant parameters and processes in the model.

At the level of sketchy knowledge the assessment is made as best professional judgement, the uncertainty is considerable both due to

limited understanding of the ecological dynamics (typically a simple conceptual model) and lack of data. However, there is also an element of uncertainty from indeterminacy, the knowledge is so limited that large totally unexpected non-linear reactions can occur, indicated by the holes in the broken lines. Statistical confidence limits can only be given at high levels of knowledge. The grey curve indicates a possible risk acceptance level, which increase as the uncertainty on the assessment decrease. This is because the general public “risk acceptance factor” is higher when the EIA appears to be less uncertain (Brun 1997).

#### *Lack of data and parameters*

In the Barents Sea and Beaufort Sea case studies the uncertainty in predicting the impact of an oil spill on bird populations is mainly due to lack of data and parameters (uncertainty as ignorance). It is believed that major factors are identified and that they can be used in simple models. In the Beaufort Sea case the predictions promise too much (they are more uncertain than they pretend to be). While in the Barents Sea case you may say the predictions promise too little as the statement given puts no upper limit for the impact. The range of likely impacts could have been presented in different scenarios and thus helped in giving an idea of potential impacts, although the uncertainty should have been underlined.

The uncertainty in the state-of-the-art model predictions of impact of seabird populations after a large oil spill, is illustrated by the early predictions after the Exxon Valdez Oil Spill. It was predicted that there would be decades with depressed large guillemot *Uria* spp. populations in contrast to the 2-3 year's duration of the measured impact. Although undetected impacts may have persisted for longer periods, because it was only possible to measure large impacts.

The fact that science can not give exact predictions of population impact is a problem in EIA. Science do have important information to contribute to the assessment. However, it is difficult to describe the knowledge on the potential impact in a way that facilitates the political discussion of acceptable risks and the selection of accept criteria. Environmental Risk Assessment Models with accept criteria like the one described by Klovning and Nilsen (See chapter 2. ) rely on trustworthy population recovery time predictions. When such predictions are not possible, the models can be problematic in EIA context, because they tend to hide the uncertainty. However, the models can be good tools to identify important risk factors.

#### *The Eastern Davis Strait Case*

In the Beaufort Sea Case the scenario approach with exact estimates of recovery was used, and in the Barents Sea detailed vulnerability and impact indexes were used. In the Eastern Davis Strait we have used a more simple assessment approach, with elements from both cases, in an assessment of potential impacts of oil spills on seabirds (Mosbech et al. 1996, Mosbech 1997).

Seasonal distribution, density, population size and population trend of seabirds have been summarised as far as possible. The vulnerability and conservation value for each season for each seabird population have been described based on five factors (Individual risk of contact with oil, Population risk of contact with oil, Fecundity,

Population trend, and Importance of the assessment area). Based on this information the populations most susceptible to significant impact have been identified and potential population effects are discussed and related to hunting bags where possible. Using a rough estimate of possible oil slick size and Brünnich's guillemot density the order of magnitude of potential bird mortality have been estimated.

The crude estimates of mortality have the advantage, compared to relative values, that they can be compared with hunting bags and thus try to put the extra oil spill mortality into perspective. However, there are large uncertainties involved and it is "best professional judgements", supported by scientific facts. It is presented in a descriptive outline attempting to communicate the uncertainties involved. The advantage of this approach is that it is rather transparent and unpretentious.

### *Science and the precautionary principle*

In a paper on how to use the precautionary principle O'Riordan and Jordan (1995) deal with the general problem that science may not be able to offer sufficient reliability to form a basis for action (see chapter 2 for a definition of the precautionary principle). The problem for science related to the precautionary principle, is that scientific methods relying on experimentation, theory falsification, verification, consistency and predictability do not cope with the larger uncertainties involved. Scientific results and uncertainties have to be interpreted in a broad context to be used in relation to the precautionary principle. O'Riordan and Jordan (1995) state that "*judgements over uncertainty are shaped by a mixture of technical knowledge, experience, peer group influences, the political mandate of the organisation in which judgement is taking place, the personalities of key decisionmakers and the general political climate in which scientist create expectations of their role and authority.*"

This uncertainty assessing is an important part of the scientific process, usually dealt with in various statistical tests of the data. However, many ecological effect assessments can not be given a formal statistical treatment due to the complexity and our ignorance of the ecological dynamic. Often statistical tests are done with data, which only are valid if some basic assumptions are true. As long as these assumptions are clearly stated and evaluated, this is totally acceptable from a scientific point of view. However in interpreting the statistical p-values the unaccounted uncertainty on the assumptions are often more or less forgotten, especially in further applications of the results. It is however important that an evaluation of the uncertainty of the assessment of the impact is done and communicated.

### *The precautionary principle and statistics*

The traditional conservative use of statistics in science increases the likelihood of missing the detection of an effect by focusing on avoiding the wrong conclusion that there is an effect, when there is none (making a Type I error) (Mapstone 1995, Buhl-Mortensen 1997). Using no-effect as the  $H_0$  hypothesis and a significant level of  $\alpha=0.05$ , typically means that while the probability of concluding that there is an effect, when there is none is 0.05, the probability (Beta level) of concluding that there is no-effect, when in fact there is an

effect is much higher (making a Type II error). Mapstone (1995) found many environmental impact monitoring programmes in which the  $H_0$  (no-effect) were not rejected. Although the likelihood of type II error was higher than 0.4 for an impact that would constitute an 80-100% change in the measured variables. This conservative use of statistics is definitely not in accordance with the precautionary principle (Mapstone 1995, Buhl-Mortensen 1997), and the high risk of Type II errors in environmental studies is seldom recognised by lay-people and decisionmakers (Agger 1998).

#### *Statistical power*

There are several possibilities for avoiding this pitfall of a high (unrecognised) probability of not detecting a real effect. The probability of making a Type II error can be calculated (Beta) and thus the power (1-Beta) of the test. The power is the probability of detecting an effect, if there is an effect. The power depends on sample size, magnitude of the effect (if it exists) and level of alpha value. Thus power can be increased if it is too low. Using a higher alpha value will increase the power of the test. This was the approach used by Day et al. (1995) which used alpha levels up to 0.2 in testing the impact of the Exxon Valdez Oil Spill on marine birds (see chapter 3). Mapstone (1995) suggests a procedure for selecting alpha and beta values where a critical effect size is chosen and given primacy. The procedure focus on the magnitudes of impacts considered important and provides for statistical decisions based on the a priori consideration of the development and environmental cost of Type I and Type II errors.

Another possibility is to use an expected effect as the  $H_0$  hypothesis, rather than the no-effect. This would switch the burden of evidens from the effect hypothesis to the no-effect hypothesis. It can only be used when there is strong(est) presumption of an effect, and it is important to recognise and acknowledge to which degree the objective of such an analysis goes beyond the objective pursuit of understanding (Williams 1997). The approach was suggested after the Exxon Valdez Oil Spill where severe effects could be expected based on e.g. the estimated number of dead birds. However, I have seen no studies where it has been used. Yet another approach is to abandon the format of comparing a null-hypothesis (no-effect) to a working hypothesis (effect), and simply look at the relative likelihood or Bayesian posterior distribution of different levels of effect, as suggested by Hilborn (1996) for Exxon Valdez oil spill studies. The Baysian statistical method can be used to calculate probabilities for different effect-levels between oiled and non-oiled sites, and thus a broader unbiased statistical description of the impact. The Baysian approach to uncertainty focuses on estimating the probability that a hypothesis is true and the updating of that probability as data accumulates (Anderson 1998).

#### *When science do not cope*

The immense research effort after the Exxon Valdez Oil Spill has contributed considerable to our knowledge on the potential impact of large oil spills, as described in chapter 3. However, evidently science did not deliver the product it was asked to deliver, neither to science nor to the public. Because of lack of prespill baseline data and lack of understanding of ecosystem dynamics it was very difficult to measure the size of the impact reliably. Had science been prepared it



could have used the spill as a large scale ecological pulse perturbation to explore the dynamic interconnectedness of biotic systems (Paine et al. 1996). Instead, research was more focused on documentation to be used in court. The Exxon sponsored research group and the government research group went into a heated dispute on methodology and size of damages (e.g. Wiens 1996, 1997, Piatt. 1997). A dispute that revealed the uncertainties of the estimates to scientists, and at the same time confused lay-people (e.g. Norton 1997). Ecological science did not deliver anything near a useful description of damage to court. On the contrary scientific evidence was given very little weight in the court. It was called a “do it yourself” jury: *“You get a guy with four PhDs saying no fish were hurt, then you get a guy with four PhDs saying, yeah, a lot of fish were hurt.....They just kind of delete each other out”* (Barker 1994 cited from Paine 1996)

### *Integrated management*

Given the limited possibilities for precise scientific predictions of impacts of large oil spills on seabirds, I have suggested that more attention is given to the integrated analysis and management of flyway populations in EIA of new oil activities (Mosbech 1997). The “extra oil spill risk” shall be seen in the context of management of the population. Research focusing on population dynamics and “bottlenecks” can provide important knowledge, which can be used operationally. Information can be used for identification of the most important areas and for supportive measures to populations facing the risk of significant impact from a large oil spill (Fig. 6.2).

It is also important to realise that measurable ecological effects are not necessarily ecologically important, but it is important to evaluate their potential ecological consequences, and the uncertainty associated with this evaluation. If uncertainty is large and potential impact is large it is appropriate to be careful. There the assessment and communication of the uncertainty from the scientist to the public and decisionmakers are very important

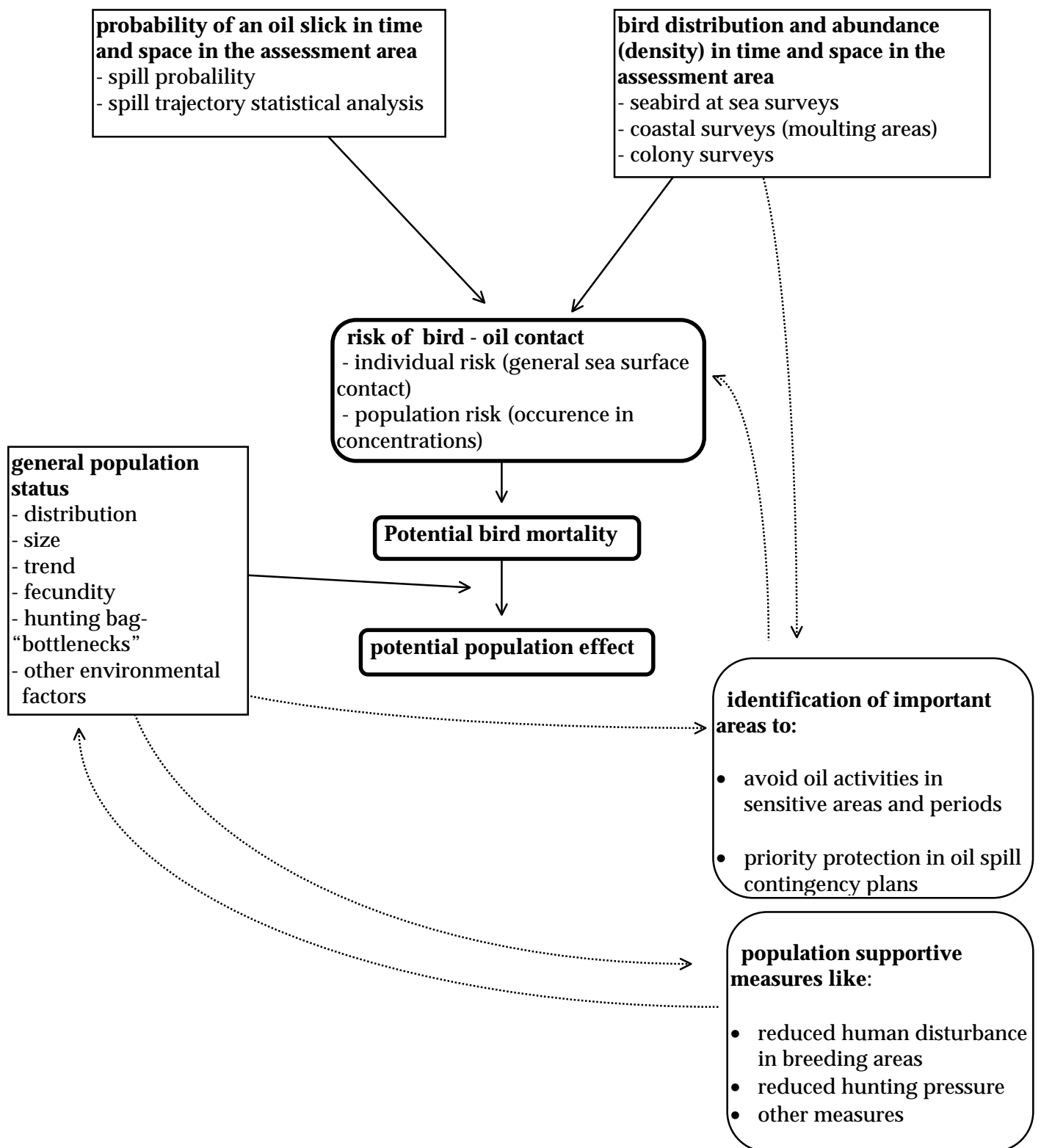

Figure 6.2. Basic principles of analysis to assess seabird vulnerability to oil activities (Mosbech 1997). Solid lines indicate the main analysis of potential effects on bird populations and broken lines the main effect of possible mitigative measures (indirect effects omitted for simplicity).

*Focus on important populations and threatened populations*

Looking at marine oil activities the most important possibilities for minimising the potential effect of a large oil spill is to plan risky activities so the most important areas and periods are avoided, and to improve the status for populations (and subpopulations and colonies) which face the risk of a large oil spill. Special consideration should be given to key species (species of particular importance), and small declining populations and threatened populations (redlisted species). The calculation of seabird oil vulnerability indices can be a valuable tool for identifying the most vulnerable areas (King and Sanger 1979, Anker-Nilssen 1988, Williams et al. 1994). See e.g. Anker-Nilssens method described in chapter 4.3. Williams et al. (1994) developed another oil vulnerability index to assess and map the vulnerability of seabirds in the North Sea. However, Williams et al.'s method does not use information on population trends, and thus seems less adequate than Anker-Nilssens to protect the most vulnerable populations. Anker-Nilssens method (1987, et al. 1988) has later been incorporated into a GIS-based analysis tool called SIMPACT (Anker-Nilssen and Kvenild 1996) and used in assessing potential effects on seabirds of petroleum activity in the northern Barents Sea (Isaksen et al. 1998).

## **6.2 The broad policy perspective**

Looking at the use of ecological scientific results in the broad perspective it is important to acknowledge how other actors look at ecological science and scientist in the modern society.

*The technological paradigm*

Often the ecological scientists are perceived as looking too reductionistic at environmental problems, as if the problems are shaped by real processes in nature alone, and if the possible society response is also thus determined. This is the dominant "technological paradigm" in environmental analysis (Szerszynski et al. 1996). The opposite paradigm, that all environmental problems are mere social constructions, does exist (surprisingly to many ecological scientist) and is just as reductionistic and inadequate. The two positions reproduce the cultural categories of modernity, nature versus culture, and are both rightly problematised as part of environmental problems (Lash et al. 1996).

*Limitations of scientific knowledge*

Another important thing to acknowledge is the limitations of scientific knowledge. As pointed out by e.g. Wynne (1996) even facts are not objective because they are part of a subjective context. He claims that scientific knowledge is pervaded with a quite indeterminate and formulaic set of communications and practices. Scientific practices are hermeneutic (based on interpretation) and indeterminate and the knowledge itself is indeterminate and uncertain. The Exxon Valdez Oil Spill studies, e.g. the different interpretations of pre-spill data for colonies of large guillemots (*Uria* spp.) mentioned in chapter 3, is an example of this. Wynne sees the claims of scientist for determinacy as a legitimating rhetoric which helps constitute the "actor-networks" of which they are the key members, but which stretch far beyond to other parts of society.

However, Wynne's (1996) main criticism of science is the strict division between scientific and lay knowledge. Scientists believe in the validity of their rhetoric thus preventing their solutions from taking into account the local knowledge of lay actors involved in ecological crisis points. Wynne (1996) presents a convincing example from radiation experts and sheep-farmers in northern England. Scientific predictions thus put the lay-man in a double blind. On the one hand the laymen are dependent on the knowledge of the experts and on the other hand they have a basic mistrust of them. The result of this constructed insecurity is fear.

### *The risk society*

The sociologist Ulrich Beck has in his book *The Risk Society* (1996, first published in German in 1986) put forward the idea, which successfully has spread, that the distribution of risk is a predominant feature of the current society. The hazards produced by the society can no longer be contained within conventionally modernist system of prediction and control. With the nuclear, chemical, and biotechnological dangers it is no longer possible for authoritative decisions to be made by groups of experts alone. Each citizen thus gets his share of the risk as of the wealth of the society. Although the risk comes from the technological development Beck's sees the environmental crisis as primarily a social crisis. The authority no longer rest with a particular social group of scientists, politicians or industrialists but has fragmented across a huge range of social groups. This has changed the society and given it a potential for a qualitative new level of selfcritique (Lash et al. 1996).

The idea of the risk society introduced by Beck in 1986, has started a sociological debate on risk and risk interpretation. Beck describes the risk as primarily a "real" risk created by the scientific-technological development. Others interpretate the focus on risk as mainly as social construction. Luhmann thus sees an overemphasis in current society on low-probability high-consequence risks, and think that this emphasis in itself creates more risks and fewer goods (Nielsen 1996, Harste 1998). The development in science and technology in this century has improved life and wealth and diminished the individual risk in modern western society considerable, although also deteriorated the biological environment.

### *A communication problem- and the need for mediative science*

However, in Luhmann's interpretation of the "risk society" the current focus and fear for technological risks is mainly unjustified and is primarily caused by problems of communication between different sectors in the society. The sectors in modern society can not communicate directly with the rest of the society. Each sector has its own codes and premises for communication and is to a large extent setting it's own speed and course. What is considered facts and uncertainties in the scientific community can be communicated as sensations in the mass media, which are not readily recognised by the scientific community. It is impossible to communicate all details and total complexity from one sector to the outside. It is a necessity to reduce complexity and details in communication. It is therefore the responsibility of the scientist to do that fair, with due concern for communicating the uncertainty of scientific results. However, there is also a need for a more "*mediative science - policy relationship, the nurturing of communicative and arbitrate mechanisms at early stages in*

*dispute resolution*” (O’Riordan and Jordan 1995) in questions where science is very uncertain.

#### *The change of the expert role*

The role of the expert in society has changed from the old authoritative expert, through the government-expert counter-expert dichotomy (in the 70’s and early 80’s), to a multitude of experts today (Agger and Nielsen 1997). Environmental problems are today discussed between a large number of experts from government institutions, private companies and a range of organisations. All these experts dominate the scene with argumentation using theoretically based system knowledge (coloured by their institutional interest) and there is a paucity of democratic debate incorporating lay-people’s experience and knowledge. Lay-people get lost in the debates between experts. To increase the democratic content and public participation in the process of finding solutions to environmental problems Agger and Nielsen (1997) focus on two tools, the Concensus Conference and the Science Workshop (Future Workshop). Both bringing lay-people and experts (scientist) together in a dialogue, where lay-people’s values, ethics and dreams set the stage for the discussions. In Concensus Conferences the panels of lay-people produce recommendations for actions to the authorities based on the dialogue. The Science Workshop is more orientated towards individual actions to work for future goals. The latter has some in common with the workshop concept in its broadest sense in the Adaptive Environmental Assessment and Management system (Holling 1978).

#### *A closed process*

In the Barents Sea Case the EIA process was conducted as a closed government institutional process until the EIA document was released. Still after the release the qualified debate seems to be primarily between government institutions. Most organisations and counties were satisfied with the EIA document. They wanted the project (economic development) and were happy with the reassurance in the EIA that it could be done environmentally acceptable. They looked at the document as authoritative, i.e. the EIA report is in the old expert role where authority (and responsibility) rest with government experts (authorities). The single environmental organisation was on the other hand totally lost in the process. How could they have confidence in the EIA document when they were aware that important government scientists involved in the assessment rejected it’s conclusion. As far as I can see in the material their concern and critique was not addressed in an open debate that could have included discussions of mitigative/compensatory measures. This maybe could have given them more confidence in the EIA process and reduced their feeling of being steam-rolled by commercial interest, although they probably would have opposed the project anyway.

The closed “keeping-control” approach and attitude of the Ministry of Oil and Energy conducting the EIA for the Barents Sea probably partly reflect insecurity because of lack of experience, as this was their first EIA. However, it also reflects the overall political tasks of the Ministry for Oil and Energy. It would probably be easier for a more independent institution (like the Canadian Environmental

Assessment Agency) to conduct an EIA that facilitated a more open democratic debate.

### *A credibility deficit*

In the Beaufort Sea Case, in contrast to the Barents Sea Case, public participation was an integrated part of the EIA right from the start and throughout the process. However, it appears that the EIA-process was looked upon by local citizens as a big resourceful but not very trustworthy machinery. Not surprisingly in Alaska few years after the Exxon Valdez Oil Spill, where so much had been promised when the oil terminal opened, and neither security systems nor oil spill combat capabilities worked as promised. A main concern among local people commenting on the EIA was protection of their traditional bowhead whale hunting. In spite of the fact that a lot of research had focused on the problem (seismic disturbance of bowheads) there still was considerable uncertainty on the assessment of the impact. A repeated comment from the local hunters was that they felt their experience and observations were not used (i.e. not taken seriously by the scientists) and that their knowledge was contradicting the scientific assessment. This is an example of the gap between scientific and lay-knowledge. In this case the hunters really had experience with the whales and they felt appalled that their knowledge was not given weight. The scientist on the other hand had to rely on scientific evidence, which in the end could pass a peer review. And the EIA-report authors relied as far as possible on the scientist to get scientific credibility for their conclusions. The scientific lay-knowledge problem has in this case recently been addressed in a workshop (MMS 1997). Here hunters and scientist discussed the hunters' observations and the disturbance of bowheads in general, not so far from the Science Workshop concept (Agger and Nielsen 1997) mentioned previously.

### *Dealing with inevitable uncertainty*

The Beaufort Sea EIA was a more open and well-established EIA-process than the Barents Sea. However, it faced the problem of large distances in culture as well as space between Inuit and scientist/bureaucrats. The inevitable uncertainty in assessing the environmental impact is evident in both the two cases studied. The problems are centred on this uncertainty in the policy-process of the EIA. Science used to be expected by the public to be able to deliver answers to all questions given enough time and money. However, science has difficulties in describing potential ecological effects and it is often the problem in EIA. Lester (1996) found that the size of the EIA-reports (for offshore oil and gas projects in the USA) was positively correlated with the number of trials on the project following in the court. He concludes that the size of the EIA does not seem to be conflict solving, continuing environmental uncertainty provides a reason or focus for continued conflict among various interests.

The uncertainty cannot be eliminated, but identifying and focusing on relevant VECs (Valued Ecosystem Components) is one important factor for minimising the uncertainty and the perception of uncertainty. Another important factor is to develop methods where scientific knowledge can merge and get into dialogue with other kinds of knowledge, without the total dominance of the scientific knowledge. When the EIA process is used outside the western

culture this bias in communication can be even more visible e.g. in Inuit cultures (Stevenson 1996).

The practical difficulties of applying ecological science in a rigorous manner in impact predictions are numerous. Science and lay-knowledge are often complementary in EIA not replacements for each other. This is a challenge for the ecological scientist involved in EIA's.

### **6.3 Conclusion**

Scientific knowledge is generally not adequate to predict the impact of a large oil spill on bird populations. The immediate mortality can only be crudely estimated and the restitution of the population can only be assessed in very broad terms with considerable uncertainty. There is a lack of understanding of the capacity for resilience in most species populations dynamic, of natural fluctuations and of the effect of other human impacts.

Experiences with impacts from actual spills, and other mass mortalities are important in the assessments because of lack of scientific understanding of the population dynamics. Also populations resiliency to hunting can be valuable information.

The resiliency must however be assessed in relation to the specific status of each population.

There is a need for focused long-term studies of species susceptible to serious impacts, to improve the understanding of resilience. And thus the predictive ability and the potential for population supportive measures.

To improve impact assessments there is a need to view the effects of oil activities of marine birds in a more holistic analysis of important bird populations that can be significantly affected. There is a need for analysis of flyway populations, identifying population dynamic parameters, bottlenecks (main regulating factors) and integrating the extra risk in management plans addressing the total impact and general situation of the population.

The most important possibility for minimising the potential effect of a large oil spill is to plan (unavoidable) risky activities so the most important areas and periods are avoided. And if possible to improve the status for populations (and subpopulations and colonies) which face the risk of serious impacts, if a large oil spill occurs.

In both the analysed cases the national energy agencies were responsible for the EIA-reports. It appears from the documents that qualified informative comments from interest groups and independent experts are one possible way to communicate the range of potential scenarios and the uncertainty involved to the public. It can either be as a supplement to the report or included in the report.

The lesson learned by the ecological scientists involved in EIA is to:

- participate in the EIA process from within the scientific tradition, but not be reluctant to give best professional judgements where needed and enter into dialogue to help bridge the gap between science and lay knowledge.
- validate methods and results as far as possible and make clear distinctions between scientific results and best professional judgement.
- pay special attention to the communication of ranges of uncertainty, including both the probabilities of not detecting real effects (type II errors), and uncertainties that can not be statistically described.
- focus research on dynamics of ecological systems where impacts are likely to occur. For example focus on key species.
- use the perturbations, whether natural or caused by project impact, to study the dynamics of systems.
- the development of an internationally accepted key to assessment of damage and potential damage to seabird populations would a usefull tool.
- to put a holistic view forward to decisionmakers to facilitate the recognition of the interconnectedness of our impacts.



## 7 References

- Adams, W.M. 1996. *Future Nature*. Earthscan, London 226 pp.
- Agger, P. and Nielsen, K.A. 1997. Viden er magt – en refleksion over viden og ekspertise i miljøreguleringen. In J. Holm et al. (ed.) *Miljøregulering tværfaglige studier*. Roskilde Universitetsforlag p. 73-93
- Agger, P. 1998. I hvor stort et omfang er der behov for at bruge forsigtighedsprincippet i miljøbeskyttelsen ? Konference om forsigtighedsprincippet København Maj 1998. *Miljønyt* nr.31, p.50-55. Miljø- og Energiministeriet, Miljøstyrelsen. (in press in english).
- Alerstam, T. and Högstedt, G. 1982. Bird migration and reproduction in relation to habitats for survival and breeding. *Ornis Scandinavica* 13: 25-37
- AMAP 1997. *Arctic Pollution Issues: A State of the Arctic Environment Report*. Arctic Monitoring and Assessment Programme, Oslo, 188pp.
- Anderson, J.L. 1998. Embracing uncertainty: The interface of Bayesian statistics and cognitive psychology. *Conservation Ecology* 2: article 2, 20 pp (available online at the internet: [www. Consecol.org/vol2/iss1/art2](http://www.Consecol.org/vol2/iss1/art2))
- Anker-Nilssen, T., Bakken, V. and Strann, K-B. 1988. Konsekvensanalyse olje/sjøfugl ved petroleumsvirksomhed i Barentshavet sør for 74°30'N. Viltrapport 46, Norsk Institutt For Naturforskning, Trondheim, 99 pp.
- Anker-Nilssen, T. 1987. Metoder til konsekvensanalyser olje/sjøfugl. Viltrapport 44, Norsk Institutt For Naturforskning, Trondheim, 114 pp.
- Anker-Nilssen, T. and Kvenild, L. 1996. SIMPACT version 3.0b. Brukerveiledning med oppdatering av modellbeskrivelse. Norsk institutt for naturforskning, Trondheim, 25 pp.
- Anker-Nilssen, T. and Røstad, O.W. 1982. Oljekatastrofen i Skagerak ved Årsskiftet 1980/81 omfang og undersøkelser . *Vår Fågelfauna* 5: 82-90.
- Arctic Environment Protection Strategy 1997. Guidelines for Environmental Impact Assessment (EIA) in the Arctic. Finnish Ministry of the Environment, Finland, 50pp.
- Bailey, E.P. and Davenport, C.H. 1972. Dieoff of Common Murres on the Alaskan Peninsula and Unimak Island. *Condor* 74: 214-219.
- Bakken, V., Brude, O.W., Hansson, R., Larsen, L.H., Løvås, S.M., Moe, K.A., Thomassen, J., and Wiig, Ø. 1997. INSROP Dynamic Environmental Atlas. Pages 280-282 in Conf. Proc., AMAP Internat. Symp. on Environmental Pollution of the Arctic, Tromsø, Norway, June 1997.

- Bakken, V., Gavriilo, M.V., Isaksen, K. and Strann K-B. 1996. Selection of marine bird Valued Ecosystem Components and descriptions of impact hypothesis in the Northern Sea Route Area. INSROP Working Paper no. 60. 56 pp.
- Bakken, V. and Mehlum, F. 1988. AKUP - slutrapport. Sjøfuglundersøkelser nord for 74 N/ Bjørnøya. Norw. Polar Res. Inst. Rep. Ser. No. 44, 179 pp.
- Barnes, P.W., Schell, D.M. and Reimnitz, E. (eds.) 1984. The Alaskan Beaufort Sea, Ecosystems and Environments. Academic Press 466 pp.
- Beck, U. 1997. Risikosamfundet – på vej mod en ny modernitet. Hans Reitzels Forlag, 395 pp. (Oversat fra tysk efter "Risikogesellschaft. Auf dem Weg in eine andere Moderne" Suhrkamp Verlag 1986)
- Beissinger, S.R. and Westphal, M.I. 1998. On the Use Of Demographic Models of Population Viability in Endangered Species Management. J. Wildl. Manage. 62: 821-841.
- Bernatowicz, J.A., Schempf, P.F. and Bowman, T.D. 1996. Bald Eagle Productivity in South-Central Alaska in 1989 and 1990 after the Exxon Valdez Oil Spill. Pages 785-798, in S.D. Rice, R.B. Spies, D.A. Wolfe and B.A. Wright, (eds.) Proceedings of the Exxon Valdez oil spill symposium. American Fisheries Society Symposium 18.
- Bisset, R. 1988. Developments in EIA methods. p. 47-61 in Wathern, P.: Environmental Impact Assessment. London Urwin Hyman.
- Bisset, R. 1992. EIA Methods. Paper given at the EIA workshop at Roskilde University Center. 13 p.
- Bisset, R. 1995. Environmental Impact Assessment: Process, Methods and Uncertainty. Paper given at the EIA workshop at Roskilde University Center. 28 pp.
- Boersma, P.D., Parrish, J.K. and Kettle, A.B. 1995. Common Murre Abundance, Phenology, and Productivity on the Barren Islands, Alaska: The Exxon Valdez Oil Spill and Long-Term Environmental Change. Pages 820-854 in P.G. Wells, J.N. Butler, and J.S. Hughes, (eds.) Exxon Valdez Oil Spill: Fate and Effects in Alaskan Waters, ASTM STP 1219, American Society for Testing and Materials, Philadelphia.
- Boertmann, D. and Mosbech, A. 1997. Breeding distribution and abundance of the great cormorant *Phalacrocorax carbo carbo* in Greenland. Polar Research 16 (2): 93-100.
- Boertmann, D., Mosbech, A., Falk, K. and Kampp, K. 1996. Seabird Colonies in Western Greenland (60° - 79° 30' N. lat.). National Environmental Research Institute, 148pp. - NERI Technical Report no. 170.
- Boertmann, D. and Mosbech, A. 1998. Distribution of little auk *Alle alle* breeding colonies in Thule District, northwest Greenland. Polar Biology 19: 206-210

- Boertmann, D., Mosbech, A. and Frimer, O. 1997. Autumn Migration of Light-Bellied Brent Geese *Branta bernicla hrota* through North-West Greenland. - Wildfowl 48:98-107.
- Boertmann, D., Mosbech, A. and Johansen, P. 1998. A review of biological resources in West Greenland sensitive to oil spills during winter. NERI Technical report No. 246. 72 pp.
- Boertmann, D., Mosbech, A., Johansen, P. and Petersen, H. 1998. Olieeftersforskning og miljø i Vestgrønland. TEMA-rapport fra DMU 17, 1998. 56pp. (udkommet på grønlandsk og dansk).
- Bourne, W.R.P. 1968. Oil pollution and bird populations. Pages 99-121 in J.D. Carthy and D.R. Arther (eds.) The biological effects of oil pollution on littoral communities. Suppl. Vol. 2, Field Studies Council, London.
- Brude, O.W., Moe, K.A., Bakken, V., Hansson, R., Larsen, L.H., Løvås, S.M., Thomassen, J., and Wiig, Ø. 1998. Northern Sea Route Dynamic Environmental Atlas. INSROP Working Paper no. 99. Norsk Polarinstitut Meddelelse 147. 58pp.
- Brun, W. 1997. Subjektive determinanter for lekfolks risikovurderinger (Lay perception of risk). Nordisk Psykologi 49, 1-11.
- Bucher, E.H. 1992. The Causes Of Extinction Of The Passenger Pigeon. Current Ornithology Vol 9: 1-36. Plenum Press, New York.
- Buhl-Mortensen, L. 1996. Type II Statistical Errors in Environmental Science and the Precautionary Principle. Marine Pollution Bulletin 32: 528-531.
- Burger, J. 1997. Effects of oiling on feeding behavior of sanderlings and semipalmated plovers in New Jersey. The Condor 99: 290-298.
- Børresen, J. A., Christie, H. and Aaserød, M. I. 1988. Åpning af Barentshavet Syd, Troms II, Troms III og sydlig del af Finnmark Vest for petroleumsvirksomhed. Konsekvens-udredning, Olje- og energidepartementet, Oslo, juni 1988. 90 pp.
- CAFF, The Circumpolar Seabird Working Group 1996. International Murre Conservation Strategy and Action Plan. CAFF (Conservation of Arctic Flora and Fauna.) 16 pp. (available at <http://www.grida.no/caff>)
- CAFF, The Circumpolar Seabird Working Group 1997. Circumpolar Eider Conservation Strategy and Action Plan. CAFF (Conservation of Arctic Flora and Fauna.) 16 pp. (available at <http://www.grida.no/caff>)
- CAFF, The Circumpolar Seabird Working Group 1998. Human disturbance at Arctic Seabird Colonies. CSWG Technical Report no. 2. 18pp. (available at <http://www.grida.no/caff>)

- Cairns, D.K. and Elliot, R.D. 1987. Oil Spill Impact Assessment for Seabirds: The role of Refugia and Growth Centres. *Biological Conservation* 40: 1-9.
- Camphuysen, C.J. 1998. Beached Bird Surveys Indicate Decline in Chronic Oil Pollution in the North Sea. *Marine Pollution Bulletin* 36: 519-526.
- Canadian Environmental Assessment Agency 1997. The International Study of the Effectiveness of Environmental Assessment. Canadian Environmental Assessment Agency and International Association for Impact Assessment. Summary available at the internet.
- Carlman, I. 1996. Programmatic and Strategic Environmental Impact Assessments – Concepts, Development, Pitfalls and Possibilities. TemaNord 589. Nordic Councils of Ministers, Copenhagen. 88 pp.
- Carney, R.S. 1996. On the Adequacy and Improvement of Marine Benthic Pre-Impact Surveys: Examples from the Gulf of Mexico Outer Continental Shelf. p.295-316 in Schmitt, R.J and Osenberg C.W.(eds.): *Detecting Ecological Impacts, Concepts and Applications in Coastal Habitats*. Academic Press. 370 pp.
- Cartwright, T.J. 1993. Modelling the World In A Spreadsheet. Environmental simulation on a microcomputer. The John Hopkins University Press, Baltimore and London. 423 pp.
- Christensen, F.T., Steensboe, J. and Mosbech, A. 199 on Port and O3: Oil Spill Simulations as a contingency planning tool offshore West Greenland. The 12th International Conference on Engineering under Arctic Conditions, Hamburg August 1993. Proceedings Vol. 2, 673-707.
- Clark, R.B. 1984. Impact of Oil Pollution on Seabirds. *Environmental Pollution (Series A)* 33: 1-22.
- Clark, R.B. 1987. Summary and conclusions: environmental effects of North Sea oil and gas developments. - *Phil. Trans. R. Soc. Lond., B*. 316: 669-677.
- Connors, P.G. 1984. Ecology of Shorebirds in the Alaskan Beaufort Littoral Zone. Pp403-416 in Barnes, P.W., Schell, D.M. and Reimnitz, E. (eds.) *The Alaskan Beaufort Sea, Ecosystems and Environments*. Academic Press. 466 pp.
- Croxall, J.P. and Rothery, P. 1991. Population regulation of seabirds: implications of their demography for conservation. Page 272-296 in Perrin C.M., J.D. Lebreton, G.J.M. Hirons (eds.): *Bird Population Studies*. Oxford University Press. 683pp.
- Day, R.H., Murphy, S.M., Wiens, J.A., Hayward, G.D., Harner, E.J. and Smith, L.N. 1997: Effects of the Exxon Valdez Oil Spill on Habitat Use by Birds in Prince Willians Sound , Alaska. *Ecological Applications* 7(2) 593-613.
- Day, R.H., Murphy, S.M., Wiens, J.A., Hayward, G.D., Harner, E.J. and Smith, L.N. 1995. Use of Oil-Affected Habitats by

- Birds After the Exxon Valdez Oil Spill. Pages 726-762. in P.G. Wells, J.N. Butler, and J.S. Hughes, (eds.) Exxon Valdez Oil Spill: Fate and Effects in Alaskan Waters, ASTM STP 1219, American Society for Testing and Materials, Philadelphia.
- De Leo, G.A. and Levin, S. 1997. The multifaceted aspects of ecosystem integrity. *Conservation Ecology* 1:3 (available at the internet at [www.consecol.org](http://www.consecol.org))
- Divoky, G.J. 1984. The Pelagic and Nearshore Birds of the Alaskan Beaufort Sea: Biomass and Trophics. Pp 417-440 in Barnes P.W., Schell D.M. and Reimnitz E. (eds.) *The Alaskan Beaufort Sea, Ecosystems and Environments*. Academic Press 466 pp.
- Dubgaard, A. 1998. Etiske og økonomiske opfattelser af bæredygtighed og forsigtighedsprincippet. Indlæg på debatmøde om miljøøkonomi. DMU og Dansk Ingeniørforening, Eigtveds Pakhus November 1998. 6 pp.
- Dunbar, M.J. 1982. Arctic Marine Ecosystems. Pp. 231-261 in: Rey L. and Stonehouse B. (ed.) 1982. *The Arctic Ocean, The Hydrographic Environment and The Fate of Pollution*. MacMillan Press Ltd. London.
- Dunnet, G.M. 1982. Oil pollution and seabird populations. *Phil. Trans. R. Soc. Lond., B.* 297: 413-427
- Dunnet, G.M. 1987. Seabirds and North Sea Oil. - *Phil. Trans. R. Soc. Lond., B.* 316: 513-524.
- Elling, B. and Schroll, H. 1992. Miljøvurderingsmetoder i USA, Canada og Danmark. EIA-center Roskilde University. 122 p.
- Elling, B. and Nielsen, J. 1997. Miljøvurdering af lovforslag, Studie i stragisk miljøvurdering og to eksempler. Miljø- og Energiministeriet, Landsplanafdelingen. København, Danmark. 119 pp.
- Erikson, D.E. 1995. Surveys of Murre Colony Attendance in the Northern Gulf of Alaska Following the Exxon Valdez Oil Spill. Pages 780-820. in P.G. Wells, J.N. Butler, and J.S. Hughes, (eds.) *Exxon Valdez Oil Spill: Fate and Effects in Alaskan Waters*, ASTM STP 1219, American Society for Testing and Materials, Philadelphia.
- Evans, P.G.H. and Nettleship, D.N. 1985. Conservation of the Atlantic Alcidae. p. 428-488 in Nettleship, D.N. and Birkhead, T.R.(eds.): *The Atlantic Alcidae*. Academic Press, New York. 574 pp.
- Everitt, R.R., Birdsall, D.A. and Stone, D. 1986. In Lewis (ed.) *Northern Hydrocarbon Development Environmental Problem Solving, Proceedings of the Eight Annual Meeting of the International Society of Petroleum Industry Biologist*, Banff Canada. p. 344-357
- Flanders, N.E., Brown, R.V., Andre'eva, Y. and Larichev, O. 1998. *Justifying Public Decisions in Arctic Oil and Gas*

- Development: American and Russian Approaches. *Arctic* 51: 262-279.
- Flyvbjerg, B. 1991. *Rationalitet og Magt. Bind 1: Det konkrete videnskab.* Akademisk Forlag Danmark 177 pp.
- Ford, R.G., Bonnell, M.L., Varoujean, D.H., Page, G.W., Carter, H.R., Sharp, B.E., Heinemann, D. and Casey, J.L. 1996. Total Direct Mortality of Seabirds from the Exxon Valdez Oil Spill. Pages 684-712, in S.D. Rice, R.B. Spies, D.A. Wolfe and B.A. Wright, (eds.) *Proceedings of the Exxon Valdez oil spill symposium.* American Fisheries Society Symposium 18.
- Ford, R.G., Wiens, J.A., Heinemann, D. and Hunt, G.L. 1982. Modelling the Sensitivity of Colonially Breeding Marine Birds to Oil Spills: Guillemot and Kittiwake Populations on the Pibilof Islands, Bering Sea. - *Journal of Applied Ecology* 19: 1-31.
- Frost, J.F. and Lowry, L.F. 1984. Trophic relationships of Vertebrate Consumers in Alaskan Beaufort Sea. Pp. 381-402 in Barnes P.W., Schell D.M. and Reimnitz E. (eds.) *The Alaskan Beaufort Sea, Ecosystems and Environments.* Academic Press 466 pp.
- Fry, D.M. and Lowenstine, L.J. 1985. Pathology of Common Murres and Cassin's Auklets exposed to Oil. *Arch. Environ. Contam. Toxicol.* 14: 725-737.
- Furness, R.W. and Monaghan, P. 1987. *Seabird ecology.* Blackie, Glasgow and London, 164 pp.
- Gaston, A.J. and Jones, I.L. 1998. *The Auks.* Oxford University Press. 349pp.
- Gjørseter, H. 1995. Pelagic Fish and the Ecological Impact of the Modern fishing Industri in the Barents Sea. *Arctic* 48 (3) p. 267-278.
- Hacquebord, L., de Korte, J. and Veluwenkamp, J.W. 1995. Introduction: Man and the Barents Sea Ecosystems. *Arctic* 48 (3).
- Hansson, R., Prestrud, P. and Øritsland, N.A. (eds.) 1990. *Assessment System for the Enviroment and Industrial Activities in Svalbard.* Norwegian Polar Research Institute. 267 pp.
- Harste, G. 1998. Risikosamfundets Viden. *Forskerforum* 113: 17-17
- Hartung, R. 1995. Assessment of the Potential for Long-Term Toxicological Effects of the Exxon Valdez Oil Spill on Birds and Mammals. Pages 693-726. in P.G. Wells, J.N. Butler, and J.S. Hughes, (eds.) *Exxon Valdez Oil Spill: Fate and Effects in Alaskan Waters,* ASTM STP 1219, American Society for Testing and Materials, Philadelphia.
- Hilborn, R. 1996. Detecting Population Impacts from Oil Spills: A Comparison of Methodologies. Page 639-644 in S.D. Rice, R.B. Spies, D.A. Wolfe and B.A. Wright, (eds.)

- Proceedings of the Exxon Valdez oil spill symposium. American Fisheries Society Symposium 18.
- Hilden, M. (ed.) 1996. MKB-kvalitet – et nordisk forslag til kvalitetskriterier. TemaNord 1996:570 29pp.
- Hilding-Rydevik, T. 1996. Behov av FoU inom Miljøkonsekvensbeskrivning. Rapport 4573 Naturvårdsverkets Forlag, Sverige. 78 pp.
- Holling, C.S. (ed.) 1978. Adaptive Environmental Assessment and Management. Wiley and Sons, Chichester. 377 pp.
- Holmes, W.N. and J. Cronshaw 1977. Biological effects of petroleum on marine birds. Pp. 359-398 in Mallins, D C. (ed.): Effects of petroleum on Arctic and Subarctic Marine Environments and Organisms. Academic Press, New York.
- Hudson, P.J. 1985. Population Parameters for the Atlantic Alcidae. p. 233-261 in Nettleship, D.N. and Birkhead, T.R.(eds.): The Atlantic Alcidae. Academic Press, New York. 574 pp.
- Hunt, G.L. 1987. Offshore Oil Development and Seabirds: The Present Status of Knowledge and Long-term Research Needs. Pages 539-586 in Boesch, D.F. and Rabalais, N.N. (eds.) Long-term Environmental Effects of Oil and Gas Development. Elsevier Applied Science Publishers LTD.
- Irons, D.B. 1996. Size and Productivity of Black-Legged Kittiwake Colonies in Prince William Sound before and after the Exxon Valdez Oil Spill. Pages 738-748, in S.D. Rice, R.B. Spies, D.A. Wolfe and B.A. Wright, (eds.) Proceedings of the Exxon Valdez oil spill symposium. American Fisheries Society Symposium 18.
- Isaksen, I., Bakken, V. and Øystein, W. 1998. Potential Effects on Seabirds and Marine Mammals of Petroleum Activity in the Northern Barents Sea. Norsk Polarinstitut, Meddelelser no. 154. 66 pp.
- Jensen, M.B., and Ekker, M. 1991. Dose dependent Effect of plumage oiling on thermoregulation of Common Eiders *Somateria mollissima* residing in water. Polar Research 10: 579-584.
- Johnson, S.R. and Herter, D.R. 1989. The Birds of The Beaufort Sea. LGL Alaska Research Associates. BP Exploration Anchorage Alaska. 372 pp.
- Kampp, K., Nettleship, D. N. and Evans, P. G. H. 1994. Thickbilled Murres of Greenland: status and prospects. In: (eds.) Nettleship, D.N., J. Burger and M. Gochfeld: Seabirds on Islands. BirdLife International. p. 133-154.- BirdLife Conservation Series No. 1.
- King, J.G. and Sanger, G.A. 1979. Oil vulnerability index for marine oriented birds. Pages 227-239 in Bartonek, J.C. and Nettleship, D.N. (eds.): Conservation of marine birds of northern North America. U.S. Fish and Wildl. Serv. Wildl. Res. Rep. 11. Washington D.C.

- Klovning, J. and Nilsen, E.F. 1995. Quantitative Environmental Risk Analysis. Proceedings of Society of Petroleum Engineers Annual Technical Conference Dallas USA. p. 461-470. Paper no. SPE 30686.
- Kuletz, K.J. 1996. Marbled Murrelet Abundance and Breeding Activity at Naked Island, Prince William Sound, and Kachemak Bay, Alaska, before and after the Exxon Valdez Oil Spill. Pages 770-785, in S.D. Rice, R.B. Spies, D.A. Wolfe and B.A. Wright, (eds.) Proceedings of the Exxon Valdez oil spill symposium. American Fisheries Society Symposium 18.
- Lash, S., Szerszynski, B, and Wynne, B. (eds.) 1996. Risk, Environment and Modernity, Towards a New Ecology. Sage Publication, London. 294 pp.
- Lebreton, J.D and Clobert, J. 1991. Bird population dynamics, management, and conservation: the role of mathematical modelling. Page 105-127 in Perrin C.M., J.D. Lebreton and G.J.M. Hiron (eds.): Bird Population Studies. Oxford University Press. 683pp.
- Leighton, F. A., Butler, R. G. and Peakall, D. B. 1985: Oil and Arctic Marine Birds: an Assessment of Risks. pp. 183-216 in Engelhardt, F.R. (ed.). Petroleum Effects in the Arctic Environment, Elsevier Applied Science Publishers, London New York.
- Lester, C. 1996. Administrative, Legal and Public Policy Constraints on Environmental Impact Assessment. P329-343 in Schmitt, R.J and Osenberg C.W. (eds.): Detecting Ecological Impacts, Concepts and Applications in Coastal Habitats. Academic Press. 370 pp.
- Levin, S.A., Grenfell, B., Hastings, A.. and Perelson, A..S. 1997. Mathematical and Computational Challenges in Population Biology and Ecosystem Science. Science 275: 334-343.
- Lewis, S.J. and Malecki, R.A.. 1984. Effects of larid productivity and population dynamics. Auk 101: 584-592.
- Loeng, H. 1991. Features of the physical oceanographic conditions of the Barents Sea. Polar Research 10: 5-18.
- Lorentsen, S. and Anker-Nilssen, T. 1993: Behavior and oil vulnerability of Fulmars *Fulmarus glacialis* during an oil spill experiment in the Norwegian Sea: Marine Pollution Bulletin 26 (3): 144-146.
- Lyngs, P. 1994. Geirfuglen, et 150 år minde. Dansk Orn. Foren. Tidsskr. 88 :49-72
- MacDonald, I.R. 1998. Natural Oil Spills. Scientific American, November 1998 p. 30-35.
- Mahaffy, L.A. 1991. Some Externeal Effects of Oil upon Water Birds: Problems in Reestablishing Water Repellency. Proceedings of the 1991 Oil Spill Conference, American Petroleum Institute: p. 723.



- Mapstone, B.D. 1995. Scalable decisions rules for environmental impact studies: Effect size, type I and type II errors. *Ecological Applications* 5: 401-410.
- Ministry of Environment and Energy 1995. Strategic environmental assessment of bills and other government proposals. Examples and experience. Copenhagen, Denmark. 55pp.
- MMS 1984. Alaska Outer Continental Shelf Proposed diapir field lease offering. Final Environmental Impact Statement. US Department of the Interior, Minerals Management Service MMS 84-0009.
- MMS 1990. Alaska Outer Continental Shelf Beaufort Sea Planning Area Oil and Gas Lease Sale 124. Final Environmental Impact Statement. US Department of the Interior, Minerals Management Service MMS 90 - 0063.
- MMS 1995. Alaska Outer Continental Shelf Beaufort Sea Planning Area Oil and Gas Lease Sale 144. Draft Environmental Impact Statement. US Department of the Interior, Minerals Management Service MMS 95.
- MMS 1996. Alaska Outer Continental Shelf Beaufort Sea Planning Area Oil and Gas Lease Sale 144. Final Environmental Impact Statement. US Department of the Interior, Minerals Management Service MMS 96 - 0012.
- MMS 1997. Arctic seismic synthesis and mitigation measures workshop. Proceedings March 5 and 6 1997 Barrow Alaska. US Department of the Interior, Minerals Management Service, OCS Study MMS 97 - 0014.
- Moe, K.A., Hansson, R. and Thomassen, J. 1997. Strategic Environmental Impact Assessment - Northern Sea Route (Russia). Results obtained during Phase 1 of International Northern Sea Route Programme (INSROP). Pages 201-203, in Conf. Proc., AMAP Internat. Symp. on Environmental Pollution of the Arctic, Tromsø, Norway, June 1997.
- Monaghan, P. 1996. Relevance of the behaviour of seabirds to the conservation of marine environments. *Oikos* 77: 227-237.
- Mosbech, A. 1991. Olieforurening. - Naturen i havet: kapitel 7 s. 26-30. Naturovervågning 90. Miljøministeriet.
- Mosbech, A. and Boertmann, D. 1999. Distribution, abundance and response to survey airplane of post-breeding king eiders (*Somateria spectabilis*) in western Greenland. *Arctic* 52: 188-203.
- Mosbech, A. and Johnson, S.R. 1999. Late Winter Distribution and Abundance of Sea-Associated Birds in Southwest Greenland, Davis Strait, and Southern Baffin Bay. *Polar Research* 18: 1-17.
- Mosbech, A. 1997: Assessment of Seabird Vulnerability to Oil Spills in the Eastern Davis Strait. In: Proceedings from the Fifth International Conference on Effects of Oil on

- Wildlife. November 3-6, 1997, University of California. pp. 32-49.
- Mosbech, A., Boertmann, D., Nymand, J., Riget, F. and Acquarone, M. 1998: The Marine Environment in Southwest Greenland. Biological resources, resource use and sensitivity to oil spill. National Environmental Research Institute, NERI Technical Report nr. 236. 205 pp.
- Mosbech, A., Dietz, R., Boertmann, D. and Johansen, P. 1996: Oil Exploration in the Fylla Area, An Initial Assessment of Potential Environmental Impacts. National Environmental Research Institute, 92pp. - NERI Technical Report no. 156.
- Mosbech, A., Dietz, R., and Boertmann, D. 1995: Environmental Impact Assessment of offshore oil exploration, production and transportation in the Arctic, with emphasis on ecological impacts of oil spills. Proceedings of the 14th International Conference on Offshore Mechanics and Arctic Engineering. Vol. IV Arctic/Polar Technology p. 193-201.
- Murphy, S.M., Day R.H., Wiens, J.A. and Parker, K.R. 1997: Effects of the Exxon Valdez Oil spill on Birds: Comparisons of Pre- and Post-Spill surveys in Prince Willians sound, Alaska. *The Condor* 99: 299-313
- National Research Council 1985. Oil in the Sea, Inputs, Fates and Effects. Steering Committee for the Petroleum in the Marine Environment Update. National Research Council, National Academy Press, Washington D.C., 601 pp.
- National Research Council 1994. Environmental Information for Outer Continental Shelf Oil and Gas Decisions in Alaska. Report from the Committee to Review Alaskan Outer Continental Shelf Environmental Information. National Research Council, National Academy Press, Washington D.C., 254 pp.
- Nielsen, T.H. 1996. Risici – i teknologien, i samfundet og i hovederne, Apropos risiko-begreberne hos Ulrich Bech, Anthony Giddens og Niklas Luhmann. *Retfærd* 73: 61-77
- Norton, H. 1997. Remembering our common goal. *BioScience* 47: 203-204
- O’Riordan, T. and Jordan, A. 1995. The Precautionary Principle in Contemporary Environmental Politics. *Environmental Values* 4: 191-212
- Oakley, K.L. and Kuletz, K.J. 1996. Population, Reproduction, and Foraging of Pigeon Guillemots at Naked Island, Alaska, before and after the Exxon Valdez Oil Spill, Pages 759-770, in S.D. Rice, R.B. Spies, D.A. Wolfe and B.A. Wright, (eds.) Proceedings of the Exxon Valdez oil spill symposium. American Fisheries Society Symposium 18.

- Olsgard, F. and Gray, J.S. 1995. A comprehensive analysis of the effect of offshore oil and gas exploration and production on the benthic communities of the Norwegian continental shelf. *Mar. Ecol. Prog. Ser.* 122: 277-306.
- Osenberg, C.W. and Schmitt, R.J. 1996. Detecting ecological impacts caused by human activities. P. 3-16 in Schmitt, R.J and Osenberg C.W.(eds.): *Detecting Ecological Impacts, Concepts and Applications in Coastal Habitats*. Academic Press. 370 pp.
- Paine, R.T. plus seven coauthors 1996. Trouble on oiled waters: Lessons from the Exxon Valdez Oil Spill. *Annu. Rev. Ecol. Syst.* 27: 197-235.
- Parker, M.W. et al. 1997. Efforts to restore the Extirpated Common Murre Colony on Devil's Slide Rock Using Social Attraction Techniques. In: *Proceedings from the Fifth International Conference on Effects of Oil on Wildlife*. November 3-6, 1997, University of California. p. 52-53
- Piatt, J.F. 1997. Alternative interpretation of oil spill data. *Bioscience* 47: 202-203.
- Piatt, J.F. and Anderson, P. 1996. Response of Common Murres to the Exxon Valdez Oil Spill and Long-Term Changes in the Gulf of Alaska Marine Ecosystem. P. 720-737 in Rice, S.D., Spies, R.B., Wolfe D.A. and Wright B.A. (eds.) : *Proceedings of the Exxon Valdez oil spill symposium. American Fisheries Society Symposium 18, Bethesda, Maryland.*
- Piatt, J.F. and Ford, R.G. 1996. How Many Seabirds Were Killed by the Exxon Valdez Oil Spill ?, Pages 712-720, in S.D. Rice, R.B. Spies, D.A. Wolfe and B.A. Wright, (eds.) *Proceedings of the Exxon Valdez oil spill symposium. American Fisheries Society Symposium 18.*
- Piatt, J.F., C.J. Lensink, W. Butler, M. Kendziorek and D.R. Nysewander 1990. Immediate Impact of the Exxon Valdez Oil Spill on Marine Birds. *Auk* 107: 387 - 397.
- Prestrud, P. 1986. Åbning av Barentshavet Syd for petroleumsvirksomhet. Forslag til konsekvensanalyser i de arktiske områder. *Norsk Polarinstitut Rapport nr. 27.* 68 pp.
- Prichard, A.K., Roby, D.D., Bowyer, R.T. and Duffy, R.T. 1997. Pigeon Guillemots as a sentinel species: a dose-response experiment with weathered oil in the field. *Chemosphere* 35: 1531-1548
- Reid, J.B. (ed.) 1997. *Seabirds in the Marine Environment. Proceedings of ICES International Symposium held in Glasgow, Scotland 22-24 November 1996. ICES Journal of Marine Science* 54 (4) 505-739. (ICES Marine Science Symposia vol. 204).

- Rhodes Jr., O.E., Chesser R.K., Smith, M.H. 1996. Population dynamics in ecological space and time. The University of Chicago Press, Chicago, USA. 388 pp.
- Rice, S.D., Spies, R.B., Wolfe, D.A. and Wright, B.A. (editors) 1996. Proceedings of the Exxon Valdez oil spill symposium. American Fisheries Society Symposium 18, Bethesda, Maryland. 931 pp.
- Riget, F., Johansen, P., Dahlgard, H., Mosbech, A., Dietz, R., and Asmund, G. 2000. The Seas Around Greenland. *In* Sheppard C.R.C. (ed.) Seas at the Millenium: An Environmental Evaluation. Vol. 1: 5-16. Elsevier.
- Ritchie, W. and O'Sullivan, M. (eds.) 1994: The environmental impact of the wreck of the Braer: The Scottish Office, Edinburgh. 207 pp.
- Ryan, P.G., and Siegfried, W.R. 1994. The Viability of Small Populations of Birds: an Empirical Investigation of Vulnerability. p 3-22 in Remmert H. (ed.): Minimum Animal Populations. Ecological Studies 106, Springer-Verlag, Berlin
- Sakshaug E., Hopkins, C.C.E. and Øritsland, N.A. (eds.) 1991. Proceedings of the Pro Mare Symposium on Polar Marine Ecology, Trondheim, Norway 12-16 May 1990. Polar Research Vol. 10 (1-2) 662 pp.
- Sakshaug, E. (ed.) 1992: Økosystem Barentshavet: Norwegian Research Program for Marine Arctic Ecology. 304 pp.
- Sakshaug, E., Bjørge, A., Gulliksen, B., Loeng, H., and Mehlum, F. 1994. Structure, biomass distribution, and energetics of the pelagic ecosystem in the Barents Sea: A synopsis. Polar Biol. 14: 405-411.
- Samuels, W.B. and Ladino, A. 1983. Calculation of seabird population recovery from potential oilspills in the mid-Atlantic region of the United States. Ecol. Model. 21: 63-84.
- Schmitt R.J., Osenberg, C.W., Douros, W.J. and Chesson, J. 1996. The Art and Science of Administrative Environmental Impact Assessment. P. 281-294 in Schmitt, R.J and Osenberg C.W.(eds.): Detecting Ecological Impacts, Concepts and Applications in Coastal Habitats. Academic Press. 370 pp
- Schmitt, R.J and Osenberg, C.W.(eds.) 1996. Detecting Ecological Impacts, Concepts and Applications in Coastal Habitats. Academic Press. 370 pp
- Schroll, H. 1995. EIA - an Introduction. Paper given at EIA workshop at Roskilde University Center, November 1995, 28 pp.
- Sharp, B.E., Cody, M. and Turner, R. 1996. Effects of the Exxon Valdez Oil Spill on the Black Oystercatcher. Pages 748-759, in S.D. Rice, R.B. Spies, D.A. Wolfe and B.A. Wright, (eds.) Proceedings of the Exxon Valdez oil spill symposium. American Fisheries Society Symposium 18.

- Sherman, K. 1991. The Large Marine Ecosystem Concept: Research and Management Strategy For Living Marine Resources. *Ecological Applications* 1 (4), pp. 349-360
- Sherman, K., Jaworski, N.A. and Smayda, T.J. (eds.) 1996. The Northeast Shelf Ecosystem, Assessment, Sustainability, and Management. Blackwell Science Inc. 564 pp.
- Spies, R.B., Rice, S.D., Wolfe, D.A. and Wright, B.A. 1996. The Effects of the Exxon Valdez Oil Spill on the Alaskan Coastal Environment. Pages 1-17, in S.D. Rice, R.B. Spies, D.A. Wolfe and B.A. Wright, (eds.) Proceedings of the Exxon Valdez oil spill symposium. American Fisheries Society Symposium 18.
- Stephenson, R. 1997. Effects of oil and other surface-active organic pollutants on aquatic birds. *Environmental Conservation* 24: 121-129.
- Stevenson, M.G. 1996. Indigenous Knowledge in Environmental Assessment. *Arctic* 49 (3) p.278-291
- Steward-Oaten, 1996. Problems in the Analysis of Environmental Monitoring Data. p. 109-132 in Schmitt, R.J and Osenberg C.W.(eds.): Detecting Ecological Impacts, Concepts and Applications in Coastal Habitats. Academic Press. 370 pp
- Strann, K.-B. and Vader, W. 1988. Registrering av sjøfugl i Barentshavet Syd. AKUP 1985-1988. Tromsø, Naturvidenskab nr. 63, 47 pp. + 74 maps.
- Stubblefield, W.A., Hancock, G.A., Ford, W.H., Prince, H.H. and Ringer, R.K. 1995. Evaluation of the Toxic Properties of Naturally Weathered Exxon Valdez Crude Oil to Surrogate Wildlife Species. Pages 665-693 in P.G. Wells, J.N. Butler, and J.S. Hughes, (eds.) Exxon Valdez Oil Spill: Fate and Effects in Alaskan Waters, ASTM STP 1219, American Society for Testing and Materials, Philadelphia.
- Szszynski, B., Lash, S., and Wynne, B. 1996. Introduction: Ecology, realism and the social sciences. Page 1 - 26 in Lash S., Szszynski, B, and Wynne B. (eds.): Risk, Environment and Modernity, Towards a New Ecology. Sage Publication, London. 294 pp.
- Tasker, M.L., Hope Jones, P., Dixon, T. and Blake, B.F. 1984. Counting birds at sea from ships: a review of methods employed and a suggestion for a standardized approach. *Auk* 101: 567-577.
- Thomassen, J., Løvås, S.M. and Vefsnmo, S. 1996. The Adaptive Environmental Assessment and Management AEAM in INSROP – Impact Assessment Design. INSROP Working Paper 31, Trondheim. 45 pp.
- Thomassen, J., Hansson, R., Hoel, E.E. and Moe, K.A. 1997. Evaluering av “Metode for miljørettet risikoanalyse – MIRA” ved bruk av AEAM-metoden. Arbeidsdokument

- fra et arbeidsseminar i Oslo 18.- 20. november 1996.  
NINA Oppdragsmelding 449: 1-125.
- Treweek, J., 1996. Ecology and environmental impact assessment. *Journal of Applied Ecology* 33: 191-199.
- Vader, W., Barret, R.T., Erikstad, K.E. and Strann, K-B. 1990 Differential responses of common and thick-billed murrelets to a crash in the capelin stock in the southern Barents Sea. *Studies in Avian Biology* 14: 175-180.
- Walton, P., Turner, C.M.R., Austin, G., Burns, M.D. and Monaghan, P. 1997. Sub-lethal effects of an oil pollution incident on breeding kittiwakes *Rissa tridactyla*. *Mar. Ecol. Prog. Ser.* 155: 261-268.
- Wells, P.G., Butler, J. N. and Hughes, J. S. (Eds.) 1995: *The Exxon Valdez Oil Spill : Fate and Effects in Alaskan Waters: American Society for Testing and Materials STP1219, Philadelphia 1995*
- White, C.M., Ritchie, R.J. and Cooper, B.A. 1995. Density and Productivity of Bald Eagles in Prince William Sound, Alaska, After the Exxon Valdez Oil Spill. Pages 762-780., in P.G. Wells, J.N. Butler, and J.S. Hughes, (eds.) *Exxon Valdez Oil Spill: Fate and Effects in Alaskan Waters, ASTM STP 1219, American Society for Testing and Materials, Philadelphia.*
- Wiens, J.A 1997. Response from John Wiens. *BioScience* 47: 204-206.
- Wiens, J.A. 1996. Oil Seabirds and Science. *BioScience* 46: 887-897.
- Wiens, J.A. and Parker, K.R. 1995. Analyzing the Effect of Accidental Environmental Impacts: Approaches and Assumptions. *Ecological Applications* 5: 1069-1083
- Wiens, J.A., Crist, T.O., Day, R.H., Murphy, S.M. and Hayward, G.D. 1996. Effects of the Exxon Valdez Oil Spill on Marine Bird Communities in Prince William Sound, Alaska. *Ecological Applications* 6: 828-841.
- Wiens, J.A. 1995. Recovery of Seabirds Following the Exxon Valdez Oil Spill: An Overview. Pages 854-894. in P.G. Wells, J.N. Butler, and J.S. Hughes, (eds.) *Exxon Valdez Oil Spill: Fate and Effects in Alaskan Waters, ASTM STP 1219, American Society for Testing and Materials, Philadelphia.*
- Wiens, J.A., Ford, R.G. and Heinemann, D. 1984. Information needs and priorities for assessing the sensitivity of marine birds to oil spills. *Biological Conservation* 28: 21-49
- Williams, B.K. 1997. Logic and science in wildlife biology. *J. Wildl. Manage.* 61: 1007-1015.
- Williams, J.M., Tasker, M.L., Carter, I.C. and Webb, A. 1994 A method for assessing seabird vulnerability to surface pollutants. *Ibis* 137: 147-152.

- Wooller, R.D., Bradley, J.S. and Croxall, J.P. 1992. Long-term population studies of seabirds. *Trends in Ecology and Evolution* 7: 111-114
- Wynne, B. 1996. May the sheep safely graze? A reflexive view of the expert-lay knowledge divide. Page 44-83 in Lash S., Szerszynski, B, and Wynne B. (eds.): *Risk, Environment and Modernity, Towards a New Ecology*. Sage Publication, London. 294 pp.

## **8 Appendices**

Appendix 1: List of animal species mentioned in the text, in British and US English, Latin and Danish, and an acronym glossary.

Appendix 2: The seabird example from the MUPS system

Appendix 3: The EIA procedure and schedule for the Beaufort Sea leasing process



## Appendix 1:

Lists of birds and other animal species and species groups mentioned in the text, in British and US English, Latin and Danish.

### Birds

English name	American name (when different)	Danish Name	Scientific name
alcids (auks)		alkefugle	Alcidae
peregrine falcon		vandrefalk	<i>Falco peregrinus</i>
Arctic tern		havterne	<i>Sterna paradisaea</i>
(common) guillemot	common murre	atlantisk lomvie	<i>Uria aalge</i>
auklets		dværgalke	
bald eagle		hvidhovedet ørn	<i>Haliaeetus leucocephalus</i>
brent goose	brant	knortegås	<i>Branta bernicla</i>
black guillemot		tejst	<i>Cepphus grylle</i>
black oystercatcher		amerikansk sort strandskade	<i>Haematopus bachmani</i>
Brünnich's guillemot	thick-billed murre	polarlomvie	<i>Uria lomvia</i>
common eider	common eider	ederfugl	<i>Somateria mollissima</i>
common gull	mew gull	stormmåge	<i>Larus canus</i>
divers	loons	lommer	<i>Gavia</i> spp.
diving ducks		dykænder	
fulmar	northern fulmar	mallebuk	<i>Fulmarus glacialis</i>
glaucous gull		gråmåge	<i>Larus hyperboreus</i>
great auk		gejrfugl	
grebes		lappedykkere	<i>Podiceps</i> spp.
large guillemots	murres	lomvier	<i>Uria</i> spp. ( <i>lomvia</i> + <i>aalge</i> )
kittiwake	black-legged kittiwake	ride	<i>Rissa tridactylus</i>
little auk	dovekie	søkonge	<i>Alle alle</i>
mallard		gråand	<i>Anas platyrhynchos</i>
marbled murrelet		marmor-dværgalk	<i>Brachyramphus marmoratus</i>
northwestern crow		amerikansk nordvest -krage	<i>Corvus caurinus</i>
long-tailed duck	oldsquaw	havlit	<i>Clangula hyemalis</i>
phalaropes		svømmesnepper	Phalaropidae
pigeon guillemot		Beringstejst	<i>Cepphus columbia</i>
(Atlantic) puffin		lunde	<i>Fratercula arctica</i>
red (grey) phalarope	red phalarope	thorshane	<i>Phalaropus fulicaria</i>
sanderling		sandløber	<i>Calidris alba</i>
semipalmated plover		amerikansk præstekrave	<i>Charadrius semipalmatus</i>
shag		topskarv	<i>Phalacrocorax aristotelis</i>
spectacled eider		brilleederfugl	<i>Somateria fischeri</i>
Steller's eider		stellersand	<i>Polysticta stelleri</i>

## Other Animal species

English name	American name (when different)	Danish name	Scientific name
Arctic char		fjeldørred	<i>Salvelinus alpinus</i>
Arctic fox		polarræv	<i>Alopex lagopus</i>
bowhead whale		grønlandshval	<i>Balaena mysticetus</i>
capelin		lodde (ammassat)	<i>Mallotus villosus</i>
cod		torsk	<i>Gadus morhua</i>
grizzly bear		brun bjørn	<i>Ursus arctos</i>
herring		sild	<i>Clupea harengus</i>
sand eel		tobis	<i>Ammodytes</i> spp.
minke whale		vågehval (sildepisker)	<i>Balaenoptera acutorostrata</i>
pinnepeds		sæler	
polar bear		isbjørn	<i>Ursus maritimus</i>
polar cod	Arctic cod	polartorsk	<i>Boreogadus saida</i>
ringed seal		ringsæl	<i>Phoca hispida</i>
walrus		hvalros	<i>Odobenus rosmarus</i>
white whale (beluga)		hvidhval	<i>Delphinapterus leucas</i>
whitefish		ørred-arter (helt m.m.)	<i>Coregonus</i> spp.

## List of acronyms

AEAM: Adaptive Environmental Assessment and Monitoring

AEPS: Arctic Environmental Protection Strategy

BEMP: Beaufort Environmental Monitoring Project

CAFF: The program for the Conservation of Arctic Flora and Fauna

DEIS: Draft EIS

EIA: Environmental Impact Assessment

EIS: Environmental Impact Statement (U.S. EIA-report)

FEIS: Final EIS

LME: Large Marine Ecosystem

MMS: Mineral Management Service (U.S. Department of the Interior)

MUPS: environmental impact studies on Svalbard (Miljøundersøkelser på Svalbard)

NRC: National Research Council (U.S.)

OCS: Outer Continental Shelf

VEC: Valued Ecosystem Component

## **Appendix 2:**

### **The seabird example from the MUPS system**

The environmental impact studies on Svalbard (Miljøundersøkelser på Svalbard (MUPS)) have included the development of an analysis system, the MUPS analysis system (Hansson 1990). To illustrate the analysis system, the seabird Valued Ecosystem Component (VEC) from Hansson et al (1990) is presented.

There is a schematic flow chart with linkages for each VEC.

By means of the linkages a number of impact hypothesis can be set up. Eight were set up for the seabirds. The hypotheses are later screened and evaluated. Two were found to be potentially valid and two were found to be valid. One of the latter is given as an example: Impact hypothesis 43 (IH 43).

Four different symbols are used in the schematic flow charts:



IMPACT OF ENCROACHMENT

VALUED ECOSYSTEM COMPONENT - VEC

SYSTEM COMPONENT  
Natural factor of importance to the VEC

LINKAGE  
indicating the direction of the impact

**LINKAGES**

Self-explanatory linkages have not been described

**VEC 7 SEABIRDS**

Seabirds have been treated as an ornithological VEC. The bird cliff vegetation and the birds' contribution to its formation have not been included. The sea birds are affected by encroachments both in the breeding and feeding areas. The types of food available have not been specified. This will vary among species and is treated in a separate flow chart (see VEC 9 Marine Biological Resources).

1. Pollution may lead to reduced access to food by causing the destruction of food organisms.
2. Oil fouling causes increased energy expenditure, by impairing the insulating properties of the plumage.
3. Pollution can cause reduced reproduction, as eggs and chicks will be soiled by adult birds fouled by oil.
4. Pollution can cause disease or direct mortality.
5. Disturbance can increase energy expenditure and thereby impair physical condition.
6. Disturbance can cause females to leave the nest for a shorter or longer period, with a resulting increase in egg and chick mortality.
7. Disturbance can cause birds to withdraw from an affected area.
8. Disturbance can reduce foraging time.
9. Edible waste can affect the glaucous gull and arctic fox populations.
10. Traffic may result in hunting.
11. Predation is the limiting factor for reproduction.
12. Increased foraging time will result in less time for the protection and warming of eggs and chicks and accordingly in reduced reproduction.
13. An inadequate food supply leading to impaired physical condition can cause birds to migrate. Migration requires energy and will therefore impair the physical condition.
14. Impaired physical condition increases disease susceptibility. Disease will impair the physical condition.
15. The quantity of food available (or the quality of the food) to a great extent determines physical condition when available foraging time is limited (during the breeding period).
16. Reduced foraging efficiency causes increased energy expenditure and accordingly impaired physical condition.
17. Impaired physical condition increases exposure to predation.
18. An increase in the populations of glaucous gull and arctic fox may imply increased predation.
19. Reduced available foraging area may imply that increased foraging time is needed.
20. The climate affects egg and chick survival and accordingly reproduction.
21. The climate affects energy expenditure and accordingly physical condition.
22. The climate affects food production and access.

**SCHEMATIC FLOW CHART  
VEC 7 SEABIRDS**

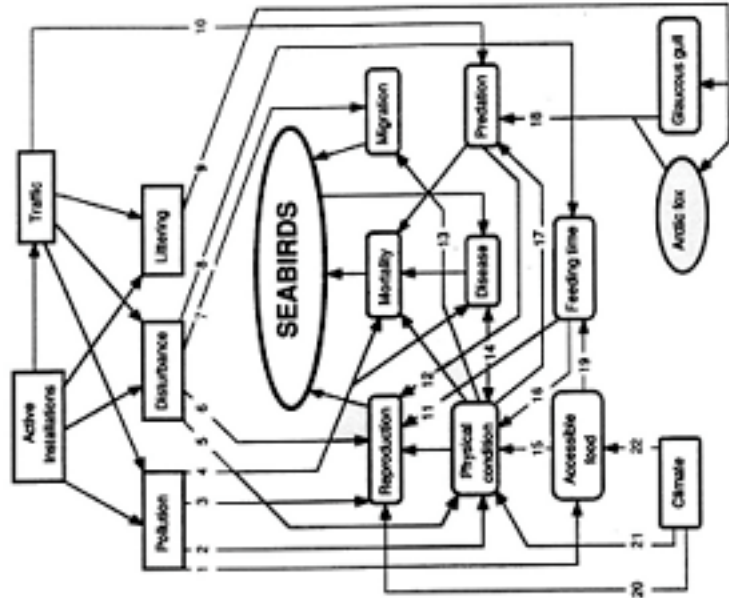

---

### 3.5 The Impact hypotheses (IHs)

The linkages in the flow chart indicate which developments will influence the VEC directly, or indirectly, via system components. A series of impact hypotheses (IHs), that is hypotheses for the impacts of the relevant developments on the VEC, can be set up by means of these links. These IHs were the basis for the final recommendation for research, monitoring, mapping and mitigating measures presented in this version of the assessment system. To avoid leaving out hypotheses, efforts were made, when preparing the first set of hypotheses, to cover all impacts that could reasonably be imagined from the very onset. Following a special screening procedure, only those hypotheses that were sufficiently probable, important or researchable for the assessment system to recommend the initiation of mapping, monitoring or research in the field remained. When revising the assessment system in the future, impact hypotheses that have now been downgraded can be upgraded and conversely. Such changes have already been made during the revision of version 1 of the system. All hypotheses, including the ones that have not been given priority in this version, have been listed on a standard diagram (chapter 8) with the following categories:

1. The hypothesis.
2. Description of the hypothesis based on a flow chart (i.e. an explanation of the hypothesis).
3. The placing of the hypothesis in one of the following categories, accompanied by argumentation for the placing:
  - A. The hypothesis is not assumed to be valid.
  - B. The hypothesis is valid and is already verified. Research to validate or invalidate the hypothesis is not required. Surveying, monitoring and/or administrative measures can possibly be recommended.
  - C. The hypothesis is assumed to be valid. Research, monitoring or surveying is recommended to validate or invalidate the hypothesis. Administrative efforts to mitigate negative effects on the environment may be recommended if the hypothesis is valid.
  - D. The hypothesis may be valid, but is not worth testing for professional, practical, economic or ethical reasons, or because it is assumed to have minor environmental repercussions. Monitoring, surveillance, and environmental enterprises are recommended to mitigate negative environmental effects.
4. Management.  
Measures, procedures etc. associated with the development to prevent or reduce harmful effects on the environment.
5. Surveying.  
The occurrence of relevant resources/features (VECs) at the relevant times/sites are surveyed, to prevent/mitigate and/or predict possible harmful effects.
6. Monitoring.  
Investigations measuring the extent of impact, or assessing the cause-effect relationship connected with a development affecting a VEC, or associated system components, in which the VEC impact as such is not under discussion.
7. Research.  
Test of a system process hypothesis, i.e. the impact of a development on a VEC or its associated components, or investigations to find the baseline measurements required for further research concerning the problems in case.

On the whole only IHs placed in categories 3B or 3C have been given priority in the active assessment system. Documentation for these IHs has been compiled, represented together with the documentation of the relevant VEC. A brief note on each of the remaining hypotheses discussed has also been included (Chapter 8) on the flow chart. In some instances management, surveying, monitoring or research potentially relevant to the hypothesis if given priority in the future has also been mentioned. These projects have, however, not been given priority within this version of the assessment system.

A.

IH 43

Oil spills occurring near of sea-bird concentrations will cause increased mortality and reduced reproduction of the population.

Seabirds are the most visible victims of oil pollution at sea, and a considerable amount of literature documenting the effect of oil on sea-birds and sea-bird populations is available (see Folkestad 1980, Stowe 1982, Evans & Nettleship 1985).

Oil floats on the sea for a while and will foul the plumage of swimming birds. Hence the waterproofing and the heat insulating properties of the feathers will be reduced, and the birds will sink deeper into the water and lose body heat. Increased energy expenditure to keep up body temperature will reduce fat deposits and gradually also muscle tissue. Besides, the birds will generally suffer internal injuries, as they will ingest oil in their attempts to cleanse themselves (see Folkestad 1980, Levy 1980, Evans & Nettleship 1985, Fry & Lowenstine 1985, Leighton *et al.* 1986 for further references). The passing on of oil from the plumage of adult birds to eggs and nestlings, with an ensuing reduction in survival rate, has been observed with several sea-bird species (Albers 1980, 1983). Fry *et al.* (1986) have recently demonstrated that even small doses of oil will cause a considerable and prolonged increase in mortality and lower breeding success during the succeeding year among the surviving birds. The same effects have been demonstrated in sea-birds that have been washed and rehabilitated after oil-injuries (Swennen 1977, Morant *et al.* 1981).

Thus, there is no doubt that oil contamination can kill large numbers of sea-birds. Whether oil also represents a great threat to sea-bird populations is contingent upon many factors, such as reproduction strategy, site tenacity and the population development (see Baillie & Mead 1982). Various models have been developed (Ford *et al.* 1982, Wiens *et al.* 1984, Hudson 1985), but at present the biological input data is generally not sufficient to provide useful results. An oil vulnerability index for sea-birds is being developed in Norway (Rikardsen *et al.* 1987; Anker-Nilssen 1987; Anker-Nilssen & Vader; in press, Anker-Nilssen *et al.* 1988).

---

### 6.8.3 Recommended measures and studies

The following surveys, monitoring and research assignments should be implemented in connection with new developments potentially affecting sea-birds in Svalbard. The projects have been listed in classified priorities (I - VI).

#### I. (To be implemented in connection with IHs 43 and 44):

Mapping of breeding colonies, moulting, foraging and resting habitats and swimming migrations. Updating of existing maps.

**Objective:** To provide an overview of the geographical areas in which sea-birds are particularly vulnerable throughout the seasons in Svalbard, so that the timing and localization of potential developments can be adapted in order to minimize the effect on sea-birds, and so that damage potential and the necessary clean-up measures can be speedily determined in the event of oil spills.

**Method:** Will vary with the species and item to be surveyed. General: Observations made from small boats, helicopters and, to some extent, from the shore for the sighting of species in coastal waters and ashore, from ships and helicopters in more open waters. Aerial photography and satellite imagery may in future be included as supplementary methodology.

**II. (To be implemented in connection with IHs 43, 44 and 45):**

Monitoring of development in selected populations near installations/development activities and in unaffected areas (control populations).

**Objective:** To record possible effects on sea-birds resulting from local development activities and from diffuse environmental changes of a general character.

**Method:** Frequent counts in permanent test fields (possibly total count of minor occurrences) before, during and possibly after the implementation of development activities.

**III. (To be implemented in connection with IHs 43, 44 and 45):**

Studies of the population dynamics of the four bird species of priority.

**Objective:** To provide insight that enables the administration of the populations, considering both natural and man-made environmental factors.

**Method:** Mark/recapture, individual studies.

**IV. (To be implemented in connection with IHs 44 and 45):**

On the basis of this recommendation a study has been carried out under the direction of MUPS concerning the reaction of Brünnich's guillemot to the noise and passing of helicopters (Fjeld *et al.* 1988, see comment under IH 44).

Study the effect of various activities (traffic, noise etc.) on breeding colonies, particularly with a view to changes in predation pressure and foraging.

**Objective:** To provide a basis for adapting development activities/traffic in order to minimize the effect on sea-birds.

**Method:** Behaviour observation of birds in test fields exposed to controlled, quantified stimuli.

**V. (To be implemented in connection with IHs 43 and 44):**

Genetic studies of the sea-bird populations in Svalbard.

**Objective:** To find whether populations are genetically, and accordingly reproductively, discrete, and therefore necessitating separate management.

**Method:** Standard comparative genetic studies.

## **Appendix 3:**

### **The EIA procedure and schedule for the Beaufort Sea leasing process**

(MMS 1996: I-1 - I-5)



## I. PURPOSE AND BACKGROUND OF THE PROPOSED ACTION

**Purpose:** The purpose of the proposed action is the offering for and subsequent exploration, development, and production of oil and gas resources on the Outer Continental Shelf (OCS) in the Beaufort Sea Planning Area to meet national energy demands.

**A. LEASING PROCESS:** The OCS Lands Act (OCSLA) charges the Secretary of the Interior with administering mineral exploration and development on the U.S. OCS and with conserving its natural resources. The Secretary has delegated authority to carry out offshore mineral development functions to the Minerals Management Service (MMS). Pursuant to this authority, the MMS has, among other things, developed programs to produce relevant information about potential effects of natural gas and oil activities on the environment (the OCS Environmental Studies Program [ESP]) and on communities and regions of Alaska as a whole (the Social and Economic Studies Program). Information produced by the ESP is used by staff analysts as part of the baseline data used in measuring the effects of any proposed OCS oil and gas lease sale. The ESP also supports monitoring of potential postsale changes in environmental conditions to provide a basis for mitigating any unforeseen effects. For specific information on the MMS studies program, refer to Appendix D. The OCS oil and gas leasing program is implemented by 30 CFR 256. Lease supervision and regulation of offshore operations are implemented by 30 CFR 250. The following steps summarize the leasing process for the proposed sale.

**1. Leasing Schedule:** The OCSLA, as amended, requires that the Secretary of the Interior prepare and maintain a 5-year OCS natural gas and oil leasing schedule and review the program annually to ensure that it is current. The present 5-year program announced by the U.S. Department of the Interior (USDOI) in July 1992 (the OCS Natural Gas and Oil Resource Management Comprehensive Program 1992-1997 (CP) (USDOI, MMS, 1992) consists of 18 proposed lease sales for the period 1992 through 1997. Six of these proposed lease sales are in planning areas offshore Alaska. Beaufort Sea Sale 144 tentatively is scheduled to be held in September 1996. The OCS 5-year leasing CP does not represent a decision to lease in a particular area. Instead, it represents only the Department's intent to consider leasing in identified areas and to proceed with the offering of such areas only if it should be determined that leasing and development would be environmentally and socially acceptable as well as technically feasible.

An Area Evaluation and Decision Process (AEDP) has been implemented for Sale 144 under the present 5-year CP. The AEDP provides a framework for the activities that precede the decision of whether and under what conditions to hold an individual OCS natural gas and oil lease sale. These activities include coordination and consultation, information acquisition, environmental studies, resource evaluations, decisions, and review and comment procedures under the OCSLA and the National Environmental Policy Act of 1969 (NEPA). This process may include an Information Base Review (IBR), Request for Interest and Comments or Request for Interest and Information (RII), Call for Information and Nominations (Call), Notice of Intent (NOI) to Prepare an Environmental Impact Statement (EIS), and scoping and other coordination meetings.

**2. Information Base Review:** The goal of this process is to document the acquisition of environmental, geologic, and economic information to be used in OCS management and decisionmaking. If it is determined that sufficient information exists to proceed with the prelease process, the MMS would implement the next step. If a determination is made that additional studies are needed before the next step can proceed, studies are requested.

Preparations for Sale 144 originally began in April 1991 with an IBR. Groups invited to attend included the Regional Technical Working Group, Alaska Eskimo Whaling Commission (AEWC), Eskimo Walrus Commission, Federal and State agencies, the North Slope Borough, village leaders, industry, environmental groups, and the general public. The final decision for the 5-year program for 1992-1997 delayed the sale date and the process was begun again. In January 1993, an Information Transfer Meeting was held in Anchorage as part of a second IBR. Information was exchanged, and although participants identified study areas and specific studies they felt would be beneficial and would enhance MMS's knowledge of the Beaufort Sea, no information needs were identified that would warrant stopping the leasing process.

**3. Request for Interest and Information:** This step obtains information to assist MMS in determining the level of industry and public interest. On December 31, 1992, an RII was published in the *Federal Register (FR)* at 57 FR 62582 as part of the IBR. The RII asked the oil and gas industry to provide up-to-date information on its interest in leasing and conducting oil and gas operations within the Beaufort Sea, Chukchi Sea, and Hope Basin Planning Areas. Other information requested from all parties included recent geophysical data; recent geological data; biological, archaeological, environmental, or socioeconomic data; recent interpretation of existing data; and recent estimates of cost of production. The area identified in the RII as available for consideration of leasing in the Beaufort Sea Planning Area was 5,420 blocks covering 29.5 million acres, as included in the draft comprehensive program for 1992-1997.

Eight comments were received. Seven responses were from oil companies, indicating a range of interest from none to high, with most companies indicating a moderate interest. The Arctic Marine Resources Commission submitted recommendations on future research and information gathering to enhance the decisionmaking process. This information, along with the results of the IBR, was considered in deciding whether to proceed with the Call and NOI.

**4. Call for Information and Nominations and Notice of Intent to Prepare an Environmental Impact Statement (EIS):** A Call/NOI to Prepare an EIS are notices published in the *Federal Register* inviting the oil industry, governmental agencies, environmental groups, and the general public to comment on areas of interest or special concern in the proposed lease-sale area.

The Call/NOI for proposed Beaufort Sea Sale 144 was published in the *Federal Register* on December 10, 1993 (58 FR 649964). In response to the Call, 12 comments and/or nominations were received: 5 companies commented and nominated blocks, 1 comment was received from the State of Alaska, 2 from USDOJ Agencies (Fish and Wildlife Service [FWS] and National Park Service [NPS]), 1 from the North Slope Borough, 1 from the Alaska Eskimo Whaling Commission, and 2 from environmental entities (Greenpeace and the Wilderness Society). The nominations received indicated interest in all 5,420 blocks. The comments received on the NOI are discussed in Section I.D, Results of the Scoping Process.

**5. Scoping:** The NOI, published in the same document as the Call (Sec. I.A.3), serves to announce and describe the scoping process followed for the EIS. The Council on Environmental Quality defines scoping as "an early and open process for determining the scope of issues to be addressed in an EIS and for identifying the significant issues related to a proposed action" (40 CFR 1501.7). It is a means for early identification of important issues deserving of study in an EIS. The intent of scoping is to avoid overlooking important issues that should be analyzed in the EIS. Comments are invited from any interested persons, including affected Federal, State, and local governmental agencies; any affected Native groups; conservation groups; and private industry. Information obtained from the IBR, RII, and the Call is considered part of scoping. Based on information gained through the scoping process—which includes staff evaluation and input—major issues, alternatives to the proposed action, and measures that could mitigate the effects of the proposed action are identified for analysis in the EIS. For proposed Beaufort Sea Sale 144, MMS held scoping meetings in Nuiqsut, Kaktovik, and Barrow March 28-30, 1994. A scoping meeting was held in Anchorage in April 1994.

**6. Proposed Action and Alternatives Memorandum (PAAM):** The purpose of this step is to determine whether to proceed with, delay, or cancel the further development and analysis of a leasing proposal. If the decision is to proceed, MMS determines and announces the scope of that review and analysis (alternatives, mitigation, and issues to be analyzed). The PAAM documents the consultation process and the information used to ensure an informed decision on the identification of the proposed action to be analyzed in the draft EIS. The PAAM reports relevant conclusions of the IBR; summarizes and analyzes responses to the Call; presents and summarizes the scoping process and the comments and concerns raised in that process; and discusses and recommends alternatives, mitigating measures, and issues to be analyzed in the draft EIS. The PAAM provides the background information necessary to make an informed decision regarding the leasing proposal.

**7. Area Identification (Area ID):** The Regional Director, MMS, uses the PAAM to make a recommendation to headquarters as to whether, when, and how to proceed with Area ID. The Area ID formally identifies the location and extent of the proposed lease sale area, and is the area of study for the EIS. A final

PAAM is prepared in headquarters, and the MMS Director forwards recommendations on the Area ID and scope of the EIS to the Secretary/Assistant Secretary, Lands and Minerals, for approval. The Secretary/ Assistant Secretary will approve or disapprove the Director's recommendation. If the decision is to proceed with preparation of the draft EIS, an Area ID announcement is made.

The PAAM was sent to the Secretary/Assistant Secretary on September 12, 1994, and the Area ID announcement for Sale 144 was made on September 13, 1994, and included 1,879 blocks covering 4 million hectares (9.8 million acres). This configuration defers the blocks off Point Barrow that comprise the whale migration corridor (Fig. II.A.1).

**8. Preparation of Draft Environmental Impact Statement (DEIS):** Consistent with Section 102(2)(C) of the NEPA, the DEIS prepared by the MMS describes the proposed lease sale and the natural and human environments, presents an analysis of potential adverse effects on these environments, describes potential mitigating measures to reduce the adverse effects of offshore leasing and development, describes alternatives to the proposal, and presents a record of consultation and coordination with others during EIS preparation.

The DEIS was filed with the U.S. Environmental Protection Agency (USEPA), and its availability was announced in the *Federal Register* on August 23, 1995, at 60 FR 43813. The public has 90 days to review and comment on the DEIS.

A copy of the proposed notice of sale was made available to the public on September 26, 1995. The availability of the proposed notice was announced in the *Federal Register* on that date at 60 FR 49629. A copy also was sent to the Governor of Alaska, pursuant to Section 19 of the OCSLA, so that he and any affected local governments may comment on the size, timing, and location of the proposed sale. Comments must reach the Secretary within 90 days after the proposed notice is released.

**9. Endangered Species Consultation:** Pursuant to Section 7 of the Endangered Species Act of 1973 (ESA), as amended, MMS consults with the FWS and the National Marine Fisheries Service (NMFS), as appropriate, to determine whether a species that is listed as endangered or threatened may be jeopardized by the proposed action. Both formal and informal consultations are conducted on the potential effects of OCS leasing and subsequent activities on endangered and threatened species in Beaufort Sea.

In accordance with the ESA Section 7 and regulations governing interagency cooperation, the MMS notified the NMFS and FWS on January 23, 1995, of the endangered and threatened species that would be included in a biological evaluation for Section 7 consultation. The NMFS responded on February 7, 1995, and the FWS responded on March 13, 1995, confirming that the species to be evaluated in the EIS were correctly specified (see Appendix F).

Requests for formal consultation on leasing and any exploration that may occur as a result of proposed Sale 144 were transmitted to the FWS and NMFS on July 31, 1995. A Biological Evaluation analyzing potential effects of this action accompanied these requests. The NMFS, in a letter dated November 16, 1995, determined that the Arctic Biological Opinion satisfies the requirement of Section 7 of the ESA for the Sale 144 planning process. The Arctic Biological Opinion, dated November 23, 1988, concluded that the proposed lease sale and exploration activities in the Beaufort Sea are not likely to jeopardize the continued existence of any endangered or threatened cetaceans. A draft Biological Opinion from FWS dated November 13, 1995, found that the proposed oil and gas lease sale and associated exploration in the Beaufort Sea would not jeopardize any listed species for which the FWS is responsible.

**10. Public Hearings:** Public hearings are held after release of the DEIS, and specific dates and locations for public hearings are announced in the *Federal Register*. The MMS obtains oral and written comments at the hearings from the interested public.

Public hearings on the DEIS for Sale 144 were held in Anchorage on October 26, Nuiqsut on November 6, Kaktovik on November 7, and Barrow on November 8, all in 1995.

**11. Recommendation and Report:** A recommendation to proceed with preparation of the FEIS was prepared based on oral and written comments received on the DEIS and the proposed Notice of Sale.

Recommendations included a new alternative, new ITL's, and modified mitigating measures. These changes are noted in Section I.G.

**12. Preparation of the Final Environmental Impact Statement (FEIS):**

Comments on the DEIS, both written and oral, have been printed in this FEIS along with responses. Major changes in the FEIS that are a part of this public review process are noted in Section I.G.

**13. Consistency Determination:** As required by the Coastal Zone Act Reauthorization Amendments of 1990, a Consistency Determination will be released once the FEIS is made available. This document is prepared to determine whether the proposed sale is consistent with the enforceable policies of the State's approved Coastal Management Program to the maximum extent practicable.

**14. Decision Document:** A decision document is then prepared that provides relevant environmental, economic, social, and technological information connected with the proposed lease sale to assist the Secretary in making a decision on whether to proceed with preparation of a final notice and, if so, what terms and conditions should be applied to the sale and leases. This document is based in part on the FEIS; comments from the Governor of Alaska on the proposed notice regarding size, timing, location, terms, and conditions of the sale; other comments received on the FEIS; a determination of consistency with coastal management plans; and biological opinions from NMFS and FWS regarding the effect of the proposed action on endangered or threatened species.

**15. Decision and Final Notice of Sale:** The entire prelease process culminates in a final decision by the Secretary/Assistant Secretary on whether to hold a lease sale and, if so, its size, terms, and conditions. The Secretary/Assistant Secretary of the Interior has the option of deferring from the sale area any or all of the area analyzed in the EIS or areas proposed for deletion after consultation with the Governor of Alaska, pursuant to Section 19 of OCSLA, as amended. The final notice of sale must be published in the *Federal Register* at least 30 days before the sale date. It may differ from the proposed notice depending on the Secretary's final decisions, i.e., size of lease sale, bidding systems, and mitigating measures.

The major analytic, decision, legal, and policy documents comprise the Sale 144 record of decision as required by Council on Environmental Quality regulations implementing NEPA. Of particular relevance are the decision documents at the Area ID stage, the EIS, the decision documents for the proposed and final Notices of Sale, the consistency determination, and the sale-related correspondence with Governors.

**16. Lease Sale:** The Beaufort Sea Sale 144 is tentatively scheduled to be held in September 1996. Sealed bids for individual blocks and bidding units (those listed in the final notice) are opened and publicly announced at the time and place of the sale. The MMS assesses the adequacy of the bids, and the Department of Justice—in consultation with the Federal Trade Commission—may review them for compliance with antitrust laws. If bids are determined to be acceptable, leases may be awarded to the highest bidders. However, the Secretary reserves the right to withdraw any blocks from consideration prior to written acceptance of a bid and the right to accept or reject bids, generally within 90 days of the lease sale.

**17. Lease Operations:** After leases are awarded, the MMS's Field Operations Office is responsible for approving, supervising, and regulating operations conducted on the lease. Prior to any exploration activities on a lease, except certain preliminary activities, a lessee must submit to MMS for approval an exploration plan, an Oil-Spill-Contingency Plan, and an Application for Permit to Drill. The Office of Ocean and Coastal Resource Management, FWS, NMFS, USEPA, NPS, U.S. Army Corps of Engineers, U.S. Coast Guard, the State of Alaska, and the public are provided an opportunity to comment on the exploration plan. The exploration plan must be approved or disapproved within 30 days, subject to the State of Alaska's concurrence or presumed concurrence with the lessee's coastal zone consistency certification (pursuant to the Federal Coastal Zone Management Act). The MMS's ESP is designed to monitor changes in human, marine, and coastal environments during and after oil exploration and development and is authorized in Section 20(b) of the OCSLA: "Subsequent to the leasing and development of any area or region, the Secretary shall conduct such additional studies to establish environmental information as he deems necessary and shall monitor the human, marine, and coastal environments of such area or region in a manner designed to provide time-series and data trend information which can be used for comparison with any previously collected data for the purpose of identifying any significant changes in the quality and productivity of such environments, for establishing trends in the areas studied and monitored, and for designing experiments to identify the causes of such changes."

# National Environmental Research Institute

The National Environmental Research Institute, NERI, is a research institute of the Ministry of Environment and Energy. In Danish, NERI is called *Danmarks Miljøundersøgelser (DMU)*.

NERI's tasks are primarily to conduct research, collect data, and give advice on problems related to the environment and nature.

Addresses:

URL: <http://www.dmu.dk>

National Environmental Research Institute  
Frederiksborgvej 399  
PO Box 358  
DK-4000 Roskilde  
Denmark  
Tel: +45 46 30 12 00  
Fax: +45 46 30 11 14

*Management*  
*Personnel and Economy Secretariat*  
*Research and Development Section*  
*Department of Atmospheric Environment*  
*Department of Environmental Chemistry*  
*Department of Policy Analysis*  
*Department of Marine Ecology*  
*Department of Microbial Ecology and Biotechnology*  
*Department of Arctic Environment*

National Environmental Research Institute  
Vejlsovej 25  
PO Box 314  
DK-8600 Silkeborg  
Denmark  
Tel: +45 89 20 14 00  
Fax: +45 89 20 14 14

*Department of Lake and Estuarine Ecology*  
*Department of Terrestrial Ecology*  
*Department of Streams and Riparian areas*

National Environmental Research Institute  
Grenåvej 12-14, Kalø  
DK-8410 Rønde  
Denmark  
Tel: +45 89 20 17 00  
Fax: +45 89 20 15 15

*Department of Landscape Ecology*  
*Department of Coastal Zone Ecology*

Publications:

NERI publishes professional reports, technical instructions, and the annual report. A R&D projects' catalogue is available in an electronic version on the World Wide Web.

Included in the annual report is a list of the publications from the current year.