

The random free energy barrier model for ac conduction in disordered solids

Dyre, J. C.

Publication date:
1988

Document Version
Publisher's PDF, also known as Version of record

Citation for published version (APA):
Dyre, J. C. (1988). *The random free energy barrier model for ac conduction in disordered solids*. Roskilde Universitet.

General rights

Copyright and moral rights for the publications made accessible in the public portal are retained by the authors and/or other copyright owners and it is a condition of accessing publications that users recognise and abide by the legal requirements associated with these rights.

- Users may download and print one copy of any publication from the public portal for the purpose of private study or research.
- You may not further distribute the material or use it for any profit-making activity or commercial gain.
- You may freely distribute the URL identifying the publication in the public portal.

Take down policy

If you believe that this document breaches copyright please contact rucforsk@kb.dk providing details, and we will remove access to the work immediately and investigate your claim.

TEKST NR 156

1988

THE RANDOM FREE ENERGY BARRIER MODEL FOR AC CONDUCTION
IN DISORDERED SOLIDS

By: Jeppe C. Dyre, IMFUFA, Roskilde Universitetscenter,
Postbox 260, DK-4000 Roskilde, DENMARK

TEKSTER fra

IMFUFA

ROSKILDE UNIVERSITETSCENTER
INSTITUT FOR STUDIET AF MATEMATIK OG FYSIK SAMT DERES
FUNKTIONER I UNDERVISNING, FORSKNING OG ANVENDELSER

IMFUFA, Roskilde Universitetscenter, Postbox 260, 4000 Roskilde

THE RANDOM FREE ENERGY BARRIER MODEL FOR AC CONDUCTION
IN DISORDERED SOLIDS

By: Jeppe C. Dyre

IMFUFA tekst nr. 156

59 pages

ISSN 0106-6242

ABSTRACT

A brief review of the history of ac ionic and electronic conduction in disordered solids is given, followed by a detailed treatment of the simplest possible realistic model: the random free energy barrier model. This model assumes the conduction takes place by hopping, where the hopping charge carriers are subject to spatially randomly varying energy barriers. The model is solved in the CTRW and the EMA approximations, and it is shown that the two solutions are almost indistinguishable. In the model, the frequency dependent conductivity is completely determined from a knowledge of the dc conductivity and the dielectric loss strength. The random free energy barrier model predicts correctly all qualitative features of ac conduction in disordered solids, and a comparison to experiments on a number of solids shows that the model is also quantitatively satisfactory.

1. INTRODUCTION

One of the most characteristic properties of electrical conduction in disordered solids is a strong dispersion of the conductivity at subphonon frequencies ($\omega \ll 10^{12}$ Hz). At very low frequencies one generally observes a constant conductivity while at higher frequencies the conductivity becomes strongly frequency dependent, varying approximately as a power of the frequency [1-5]. The increase in conductivity continues right up to phonon frequencies. This behaviour is observed in a wide variety of non-metallic disordered solids and has been studied extensively during the last 30 years. The classes of disordered solids investigated include: ionic conductive glasses [6,7,8], ionic or electronic conducting polymers [9,10], organic semiconductors [11], amorphous semiconductors [1-4], non-stoichiometric or highly defective crystals (e. g. oxides) [12], or doped semiconductor single crystals [13]. Even highly viscous liquids behave as a disordered solid as regards ionic conduction.

All disordered solids show the same behaviour with respect to their ac properties. This is true not only for the frequency dependence but also for the temperature dependence, where a strongly temperature dependent (usually Arrhenius) dc conductivity is observed, while the ac conductivity depends much less on temperature and becomes almost temperature independent as $T \rightarrow 0$. This uniform behaviour of $\sigma(\omega, T)$ for very different solids has been pointed out a number of years ago [2,3,5,14] but is still not generally appreciated. And indeed, the fact that ionic and electronic conducting solids show similar behaviour is quite surprising. It means that we cannot expect to learn much about

microscopic details of a solid from measuring the frequency or temperature dependence of the conductivity.

As witnessed by a large number of publications and a continued interest in the field, ac conduction in disordered solids is a subject of interest on its own. More often, however, the focus is on dc transport only. It is important to realise that, even in these cases, a proper understanding of ac conduction is important in order to arrive at a correct picture of the dc transport. This is because dc and ac conduction are both due to the same mechanism (sec. 2). In particular, this implies that a new interpretation of the dc conductivity activation energy is necessary. As shown in sec. 3, the dc activation energy is the maximum of a whole range of activation energies needed to account for the frequency dispersion. This fact is important for a proper understanding of transport in disordered solids. It implies that most present models for dc conduction, thermopower, Hall effect, etc, in disordered solids, are too simple to be realistic.

The simplest and indeed the most common explanation for increasing conductivity with increasing frequency is the existence of one or the other kind of inhomogeneities in the solid. This is consistent with the fact that strong frequency dispersion of the conductivity is observed only in disordered solids. The inhomogeneities may be of a microscopic or a more macroscopic nature. In this paper hopping models will be discussed. In hopping models one makes the assumption of inhomogeneity on the atomic scale, by assuming randomly varying jump frequencies for the charge carriers. It is the purpose of this paper to show that even very simple hopping models are able to give a qualitatively correct picture of ac conduction in

disordered solids. By taking some care in deriving the models, it is hoped that the paper may contribute to make hopping models more popular among experimentalists. The paper, which summarises, clarifies and extends recent work by the author [15-18], has the following outline: Sec. 2 briefly reviews the history of the subject. In sec. 3 a general discussion of hopping models is given. It is argued that in order to arrive at realistic hopping models, any effect of a cut-off at large jump frequencies should be eliminated. In sec. 4 we discuss what is probably the simplest possible model which explains all observations, a model based on the assumption of randomly varying free energy barriers for jumps. This model is solved in the CTRW and in the effective medium approximation, and it is shown that the two solutions are almost identical. Finally, in sec. 5 a discussion is given.

2. AC CONDUCTION IN DISORDERED SOLIDS: A BRIEF REVIEW

Frequency dependent conduction in disordered solids is a very broad field and probably nobody has a full general view of it. Different schools have emerged within the field [5]. Though using different terminology, these schools discuss quite similar experimental facts. In reviewing the field it is convenient to follow the terminology of the different schools and only subsequently point out the similarities.

Historically one can distinguish two schools depending on the preferred way of presenting data [5]. The "dielectric" school uses the dielectric constant $\epsilon(\omega) = \epsilon'(\omega) - i\epsilon''(\omega)$ while the "semiconductor" school prefers to speak about the conductivity $\sigma(\omega) = \sigma'(\omega) + i\sigma''(\omega)$. These two quantities are related by

$$\epsilon_0 \epsilon^*(\omega) = \frac{\sigma(\omega) - \sigma(0)}{i\omega} \quad (1)$$

where ϵ_0 is the vacuum permittivity. More recently it has become popular to present ionic conductivity data in terms of the electric modulus, $M(\omega) = M'(\omega) + iM''(\omega)$, defined [19] by

$$M(\omega) = \frac{i\omega}{\sigma(\omega)} \quad (2)$$

The use of $M(\omega)$ has the advantage that there is no contribution to $M''(\omega)$ from electrode capacitances. Also, it is not necessary to subtract $\sigma(0)$ from $\sigma(\omega)$ in order to get peaks in the imaginary part. Finally, even the impedance $Z(\omega) = Z'(\omega) - iZ''(\omega)$ is sometimes used for presenting data, usually plotted in a complex impedance diagram, i. e. with $x = -Z'(\omega)$ and $y = -Z''(\omega)$ [7].

For a more extensive review of ac conduction in disordered

solids were carried out by workers within the dielectric school about 30 years ago. Typical systems considered were ionic conductive oxide glasses [6,20]. These solids were studied much because of technological interest: An understanding of the dielectric loss in glass as function of frequency and temperature became important for the electric industry in the fifties when one started to construct large transmitting valves, X-ray tubes and similar products [21]. Since dielectric loss in liquids had already been studied for many years, it was natural to report observations in terms of the dielectric loss. In glasses, however, it is necessary to subtract the non-zero dc conductivity in order to get proper dielectric loss peaks (eq. (1)). This was done without further justification, although it was soon discovered that there is a close correlation between dc conduction and dielectric loss [22].

The main features of dielectric loss in ionic conductive glasses, as established by the end of the fifties [6,20,22,23], are: 1) very broad dielectric loss peaks with a temperature independent shape and an almost frequency independent loss at high frequencies, and 2) an Arrhenius temperature dependent dielectric loss peak frequency ω_m with the same activation energy as the dc conductivity. Point two means that ω_m and $\sigma(0)$ are proportional. It was soon discovered that the constant of proportionality is almost universal, varying only weakly with temperature and glass composition [23]. A closer analysis of the proportionality was carried out by Barton, Nakajima and Namikawa [24-26] who found the following equation to be valid for most glasses

$$\sigma(0) = p \Delta \epsilon \epsilon_0 \omega_m \quad (3)$$

Here $\Delta\epsilon$ is the dielectric loss strength, i. e. $\Delta\epsilon = \epsilon(\omega) - \epsilon(\infty)$, and p is a temperature independent numerical constant of order one. At ordinary temperatures $\Delta\epsilon$ is usually not very much different from one, thereby explaining the approximate universality of $\sigma(\omega)/\omega_m$. Equation (3), which applies also for electronic conducting disordered solids [27,28], will be referred to as the BNN-relation [18]. It carries very important information, telling us that ac and dc conduction are closely correlated and must be due to the same mechanism. A number of models have been proposed to explain the BNN-relation but none of these models can explain at the same time the broad loss peaks without violating the BNN-relation [18].

Perhaps the earliest model for ac properties of ionic glasses is Stevels' and Taylor's random potential energy model [20,22,29]. This model was only qualitative and did not discuss the BNN-relation. In the model it is assumed that the ions feel a more or less randomly varying potential energy deriving from the random network structure of the glass. For dc conduction the largest energy barriers have to be overcome, while lower barriers are involved for ac conduction since only a limited distance has to be travelled. Though quite attractive, it was for many years believed that this model is inconsistent with experiments. It was thought that the model predicts a lower activation energy for ω_m than for $\sigma(\omega)$, and also that a distribution of activation energies implies a temperature dependent shape of the loss peak [7,8,14]. Both things are wrong as becomes evident in secs. 4 and 5 where a model is discussed which is essentially nothing but Stevels' and Taylor's old random potential energy model.

Work within the semiconductor school started in 1961 when

Pollak and Geballe measured the ac properties of n-type crystalline silicon at very low temperatures [13]. They observed an approximate power law for the ac conductivity

$$\sigma'(\omega) \propto \omega^s \quad (4)$$

with an exponent s close to 0.8. Since then it has been customary to speak about power-law frequency dependences, inferred from straight lines in log-log plots. However, even almost perfectly straight lines does not mean that $\sigma'(\omega)$ is an exact power-law. This is not always remembered, and equations like (4) have created some confusion in the field by being taken literally. To avoid this, one should preferably only speak about approximate power-laws when discussing experiments.

During the sixties the study of amorphous semiconductors emerged as a new and exciting field within semiconductor physics. As regards ac properties it was soon found that all amorphous semiconductors obey eq. (4), and for most systems studied one found values of s close to 0.8 [4]. A simple model for this is the pair approximation which was advanced by Austin and Mott in 1969 [30], generalising Pollak's and Geballe's ideas [13]. The pair approximation assumes that ac losses are due to tunneling between pairs of localised states. For a random distribution of tunneling distances one finds an approximate power-law ac conductivity with exponent given by [30]

$$s = 1 + \frac{4}{\ln(\omega \tau_{ph})} \quad (5)$$

where τ_{ph} is a typical phonon time. For ordinary laboratory frequencies eq. (5) gives $s \approx 0.8$. Despite this success, the

pair approximation has a number of problems and today it cannot be regarded as a serious candidate for explaining experiments: Equation (5) predicts s is a weakly decreasing function of frequency whereas experimentally s is weakly increasing [31]. Also, the pair approximation cannot explain the transition to frequency independent conductivity at low frequencies -- an expression of the form $\sigma(\omega) = \sigma(0) + A\omega^s$ does not fit data at low frequencies where a loss peak appears, showing that ac and dc conduction are due to the same mechanism [5, 28]. Finally, it has been found that $s \approx 0.8$ is not universally valid since s always converges to one as T goes to zero [31, 32].

More refined models were suggested in the seventies and early eighties considering hopping models, i. e. random walks in systems with spatially randomly varying jump frequencies. This approach was developed by Scher and Lax in 1973 [33] building on earlier ideas of Miller and Abrahams [34]. Scher and Lax calculated $\sigma(\omega)$ in their hopping model by approximating the spatially inhomogeneous markovian random walk by a homogeneous non-markovian Montroll-Weiss type "continuous time random walk" (CTRW) [35]. Today the CTRW approximation is recognised as the simplest possible non-trivial mean-field approximation for calculating $\sigma(\omega)$ in random media. Around 1980 the coherent potential approximation [36, 37] was introduced independently by several workers in the field, where it became known as the effective medium approximation (EMA) [38-41]. Attempts were also made to improve the pair approximation. The correlated barrier hopping model is a version of the pair approximation which predicts $s \rightarrow 1$ as $T \rightarrow 0$ [32, 42]. Alternatively, by returning to the original Miller-Abrahams equivalent-circuit, Summerfield and Butcher succeeded in joining the pair approximation smoothly to

the dc conduction in their extended pair approximation (EPA) [43]. In practical applications the EPA is very similar to the EMA, both approximations lead to selfconsistency equations for $\sigma(\omega)$.

Hopping models are markovian, i. e. the charge carrier jump probabilities are assumed to be time independent, and this leads to simple exponential decays of the probability for a charge carrier to stay at a given site in the solid. The observed pronounced frequency dispersion of the conductivity is attributed to spatial disorder in the solids, resulting in broad distributions of relaxation times (waiting times). A completely different approach to the problem is possible, however, namely to assume the fundamental hopping process is itself non-exponential [44,45]. Models along these lines have not yet come up with definite predictions about $\sigma(\omega)$, typically there is in the models one adjustable parameter corresponding to s in eq. (4). At present there seems to be no reason to assume fundamental non-markovian processes to lie behind the ac conduction and therefore only models based on simple exponential decays will be considered in this paper.

The dielectric and the semiconductor schools not only present data in terms of different quantities but they also have different emphasis [5]. Workers from the dielectric school were always mainly interested in the loss peaks and did not put much effort into an investigation of the region of frequencies much larger than the loss peak frequency. In contrast, this region has always been regarded as of main interest by the semiconductor school. This is because no frequency dependence analogous to eq. (4) is found in single-crystal semiconductors where $\sigma(\omega) = \sigma(0)$ up to microwave frequencies. Also, experimentalists within the

semiconductor school traditionally assumed ac conduction to take place by a mechanism completely different from that behind the dc conduction, thereby making irrelevant any detailed investigation of the frequency region where the transition to dc conduction occurs.

As regards the question of the best way of presenting data we suggest $\sigma(\omega)$ is to be preferred compared to $\epsilon(\omega)$ or $M(\omega)$. The conductivity is the more fundamental quantity, being directly related to the equilibrium current-current fluctuations via the Kubo formula [46]

$$\sigma(\omega) = \frac{1}{3kTV} \int_0^{\infty} \langle \bar{J}(0) \cdot \bar{J}(t) \rangle e^{-i\omega t} dt, \quad (6)$$

where \bar{J} is the total current in volume V , k and T have their usual meaning. Reflecting also the fundamental nature of the conductivity is the fact that the dissipation per unit time and unit volume is $\sigma'(\omega)/2$ times the square of the current density. Finally, there is no simple interpretation of $\epsilon(\omega)$ or $M(\omega)$ as defined by eq. (1) in terms of fluctuating dipole moments. A focus on the dielectric loss does have some merit, though. As mentioned already, the very fact that peaks in $\epsilon''(\omega)$ are seen at all is very important, since this demonstrates that dc and ac conduction are both due to the same mechanism. Also, the early discovery of the BNN-relation for ionic glasses was due to the dielectric school while the analogue for amorphous semiconductors only recently has been firmly established [28, 47].

We end this section by listing the general features of ac conduction in disordered solids which are observed almost without exception and which a satisfactory model should explain

[1-6, 28, 31, 32]: 1) For $\sigma'(\omega)$ one observes an approximate power-law

with an exponent s less than or equal to one, and usually close to one. If any deviations from a power-law are seen it corresponds to a weakly increasing $s(\omega)$. 2) At lower frequencies there is a gradual transition to a frequency independent conductivity. The transition takes place around the loss peak frequency. 3) Whenever the dc conductivity is measurable there is always a dielectric loss peak. The peak frequency satisfies the BNN-relation eq. (3). When there is no measurable dc conductivity the exponent s is very close to one. 4) As regards the temperature dependence, $\sigma(0)$ and ω_m are usually Arrhenius with the same activation energy though more complicated temperature dependences are occasionally observed, e. g. in group IV amorphous semiconductors. 5) The shape of the loss peak is temperature independent. 6) The ac conductivity is less temperature dependent than the dc conductivity (when considered in the usual log-log plot of fig. 1). For $s=1$ the ac conductivity is practically independent of temperature. 7) The exponent s depends on temperature and for $T \rightarrow 0$ one finds $s \rightarrow 1$. Thus, the ac conductivity becomes almost temperature independent as $T \rightarrow 0$. 8) Even though $\sigma(0)$ may vary many orders of magnitude, the ac conductivity varies only relatively little (one or two orders of magnitude) for different solids and different temperatures. -- In sec. 4 a simple hopping model will be considered which can explain all these facts, but first a general discussion of hopping models is given.

3. HOPPING MODELS

Though a complete model for glass ionic conductivity does not exist today, the basic transport mechanism, namely thermally activated hopping across an energy barrier described by Eyring's rate theory [48], is seldomly disputed. Being a stochastic theory, rate theory leads to simple exponential decays for the probability of staying at an energy minimum for a quasi-particle. Conductivity described by rate theory is usually referred to as hopping conductivity. While ionic conductivity is a classical thermally activated process, electronic conductivity is believed to be of quantum-mechanical nature. The fact that the two kind of conduction in disordered solids are quite similar is surprising and must provide an important piece of information. The simplest explanation of the analogy is that even electronic conduction in disordered solids is to be described by a hopping model. In fact, hopping between pairs of localised states has always been assumed to explain ac conduction in amorphous semiconductors, while dc transport, with the important exception of Mott's variable range hopping model [4], traditionally has been thought to take place via extended state conduction. Since dc and ac conduction are due to the same mechanism (sec. 2), however, this approach must be abandoned and one has to assume dc conduction is due to hopping as well. In the electronic case, the basic transport mechanism is probably quantum-mechanical tunneling between localized states. To ensure energy conservation the tunneling must be phonon-assisted. This destroys any quantum coherence effects and electronic hopping is thus of stochastic nature just as ionic hopping.

Electrons are fermions, of course, but even ions behave as

fermions as regards their hopping properties. This is because the Coulomb repulsion between ions and the finite ion size imply there is only room for one ion in each potential energy minimum in the solid. In the master equation description of hopping fermions, it is usually assumed that transitions involve only hop of a single fermion. Even then, the master equation is very complicated and further simplifications must be introduced to arrive at a tractable model. By assuming the site occupation numbers do not fluctuate in time it is possible to "project" the master equation into three dimensions, thereby getting rid of any interactions between the particles including that induced by fermistatistics [49]. The resulting master equation describes hopping of non-interacting "quasi-particles" and this is what is usually meant by a hopping model. It is important to remember, however, that hopping models are built on mean-field assumptions which are far from obvious and cannot be justified in general [50].

The basic fact about ac conduction in disordered solids is that $\sigma'(\omega)$ is an increasing function of frequency. It can be proved that any hopping model has this feature [51]. This is not surprising, since by hopping backwards and forwards at places with high jump probability a quasi-particle may sizably contribute to the ac conductivity, while the dc conductivity is determined by the overcoming of unfavorable places in the solid for the formation of a continuous "percolation" path between the electrodes. The higher the frequency of the electric field, the larger is the ac conductivity because better use is made of the sites with very large jump probability. As illustrated in fig. 2, the increase in conductivity continues as long as the frequency is lower than the maximum quasi-particle jump frequency

(jump probability per unit time) in the solid. For larger frequencies the conductivity stabilises and becomes constant.

In order to arrive at a conductivity which increases for many decades of frequency one must assume the jump frequency distribution covers roughly speaking equally many decades. In comparison, the jump distances vary only relatively little. This may be rationalised by assuming all jump distances are the same, i. e. considering the quasi-particle random walk to take place on a simple cubic lattice. The stochastic "equation of motion" for a quasi-particle is now the following master equation

$$\frac{\partial P(\bar{s}, t)}{\partial t} = -\gamma_{\bar{s}} P(\bar{s}, t) + \sum_{\bar{s}'} \Gamma(\bar{s}' \rightarrow \bar{s}) P(\bar{s}', t), \quad (7)$$

where $P(\bar{s}, t)$ is the probability to find the particle at lattice site \bar{s} at time t , $\Gamma(\bar{s}' \rightarrow \bar{s})$ is the jump frequency for jumps between site \bar{s}' and \bar{s} , usually assumed to be non-zero only when \bar{s}' and \bar{s} are nearest neighbours, and

$$\gamma_{\bar{s}} = \sum_{\bar{s}'} \Gamma(\bar{s} \rightarrow \bar{s}'). \quad (8)$$

To mimic the disorder of the solid, the Γ 's are assumed to vary randomly according to a probability distribution $p(\Gamma)$.

The basic problem we face now is to calculate $\sigma(\omega)$ from $p(\Gamma)$.

This is not easy and suitable approximations have to be done.

Below, the derivation of the CTRW and the EMA approximations is briefly sketched.

Adopting the bra and ket notation of quantum-mechanics, eq.

(7) can be rewritten as

$$\frac{\partial}{\partial t} |\psi(t)\rangle = H |\psi(t)\rangle \quad (9)$$

where $|\psi\rangle = \sum_{\bar{s}} P(\bar{s}) |\bar{s}\rangle$ is the state with probability $P(\bar{s})$ of finding a particle at site \bar{s} , and

$$H = - \sum_{\bar{s}} \chi_{\bar{s}} |\bar{s}\rangle \langle \bar{s}| + \sum_{\bar{s}, \bar{s}'} \Gamma(\bar{s}' \rightarrow \bar{s}) |\bar{s}\rangle \langle \bar{s}'|. \quad (10)$$

The solution of eq. (9) is $|\psi(t)\rangle = \exp(Ht) |\psi(t=0)\rangle$. By two partial integrations the Kubo formula for $\sigma(\omega)$ (eq. (6)) reduces to [33]

$$\sigma(\omega) = - \frac{n q^2 \omega^2}{6 k T} \int_0^{\infty} \langle \Delta R^2(t) \rangle e^{-i\omega t} dt, \quad (11)$$

where q and n are charge resp. density of the quasi-particles and $\langle \Delta R^2(t) \rangle$ is the mean-square displacement of a particle in time t . A convergence factor $\lim_{\epsilon \rightarrow 0} \exp(-\epsilon t)$ is implicitly understood in the integral. If all sites are equally populated in thermal equilibrium, i. e. have the same energy, eq. (9) now becomes

$$G(\omega) = - \frac{n q^2 \omega^2}{6 k T} \frac{1}{N} \sum_{\bar{s}, \bar{s}'} (\bar{s} - \bar{s}')^2 \langle \bar{s} | G(i\omega) | \bar{s}' \rangle \quad (12)$$

where N is the number of lattice sites and G is the resolvent or Green's function operator for the "Hamiltonian" H :

$$G = \frac{1}{i\omega - H}. \quad (13)$$

The Green's function depends on the actual values of the Γ 's. Hopping systems in three dimensions are believed to be selfaveraging, so only the average of G over all possible H 's, $\langle G \rangle$, needs to be evaluated in order to find $\sigma(\omega)$. $\langle G \rangle$ is

translationally invariant and we now make the ansatz

$$\langle G \rangle = \frac{1}{i\omega - H_c} \quad (14)$$

Here $H_c = H_c(\omega)$ is a "coherent" Hamiltonian determined by a coherent jump rate $\Gamma_c(\omega)$ in the following way: $H_c = \Gamma_c \left(-\epsilon \sum_{\mathcal{S}} |\mathcal{S}\rangle \langle \mathcal{S}| + \sum_{\mathcal{S}\mathcal{S}'} |\mathcal{S}\rangle \langle \mathcal{S}'| \right)$ where the double sum is over nearest neighbours only. It is not hard to show from eqs. (12) and (14), and indeed intuitively obvious, that $\sigma(\omega)$ is directly proportional to $\Gamma_c(\omega)$ [52]. For simplicity from now on we adopt the unit system in which the constant of proportionality is one, i. e. $\sigma(\omega) = \Gamma_c(\omega)$.

To derive the CTRW approximation we write $H = H_0 + V$ where H_0 is the diagonal part and V the off-diagonal part of H . If G_0 is the Green's function for H_0 , the standard perturbation expansion is [36]

$$G = G_0 + G_0 V G_0 + G_0 V G_0 V G_0 + \dots \quad (15)$$

Averaging this expression one finds, if all correlations are ignored,

$$\langle G \rangle = \langle G_0 \rangle + \langle G_0 \rangle \langle V \rangle \langle G_0 \rangle + \langle G_0 \rangle \langle V \rangle \langle G_0 \rangle \langle V \rangle \langle G_0 \rangle + \dots \quad (16)$$

which implies $\langle G_0 \rangle \langle G \rangle^{-1} + \langle G_0 \rangle \langle V \rangle = 1$. Taking a diagonal element of this operator identity we get the CTRW approximation for in our rationalised unit system [33, 41, 52, 53]

$$\frac{1}{\sigma(\omega) + i\omega} = \left\langle \frac{1}{\gamma + i\omega} \right\rangle. \quad (17)$$

The original derivation of the CTRW approximation was made

for a non-markovian random walk in a homogeneous medium characterised by a so-called waiting time distribution function [33]. This derivation is inconsistent since the assumption of spatial homogeneity implies the current autocorrelation function is a delta function, and thus $\sigma(\omega) \approx \delta(\omega)$ from eq. (6) [54,55]. The derivation of eq. (17) given above is due to Odagaki and Lax [41,52]. Here the CTRW approximation appears as the simplest possible non-trivial mean-field approximation. The magnitude of the dc conductivity is usually quite wrong in the CTRW, however, throwing doubt on the approach [56]. A more reliable way of evaluating $\sigma(\omega)$ is the EMA [38-41], where the idea is to focus on a particular link of the lattice. Assuming here, as above, that all site energies are equal, one has $\Gamma(\bar{s} \rightarrow \bar{s}') = \Gamma(\bar{s}' \rightarrow \bar{s})$. The link is considered to be embedded in an average medium described by the $\langle G \rangle$ of eq. (14) and one now requires selfconsistency, so that, on the average, the system of link plus average medium is described by $\langle G \rangle$. Writing the effective Hamiltonian for this system, H_{eff} , as $H_{eff} = H_c + V$ where $V = (\sigma(\omega) - \Gamma(\bar{s} \rightarrow \bar{s}')) |a\rangle \langle a|$ ($|a\rangle = |\bar{s}\rangle - |\bar{s}'\rangle$), the standard expansion eq. (15) yields for the Green's function for H_{eff}

$$G_{eff} = \langle G \rangle + \langle G \rangle T \langle G \rangle \quad (18)$$

where

$$T = V + V \langle G \rangle V + \dots = V (1 - \langle G \rangle V)^{-1} \quad (19)$$

The selfconsistency requirement, $\langle G_{eff} \rangle = \langle G \rangle$, now leads to $\langle T \rangle = 0$. A straightforward calculation with 2×2 -matrices referring to site \bar{s} and \bar{s}' shows that $\langle T \rangle = 0$ is equivalent to [39,41]

$$\left\langle \frac{\Gamma - \sigma(\omega)}{1 - 2 [\langle \bar{3} | \langle G \rangle | \bar{3} \rangle - \langle \bar{3} | \langle G \rangle | \bar{3}' \rangle] [\sigma(\omega) - \Gamma]} \right\rangle = 0. \quad (20)$$

This is the EMA equation for $\sigma(\omega)$; it can be simplified somewhat by noting that

$$\langle \bar{3} | \langle G \rangle | \bar{3} \rangle - \langle \bar{3} | \langle G \rangle | \bar{3}' \rangle = \frac{1 - i\omega \langle \bar{3} | \langle G \rangle | \bar{3} \rangle}{6 \sigma(\omega)} \quad (21)$$

which follows from evaluating the diagonal element of eq. (14) written as $(i\omega - H_c) \langle G \rangle = 1$.

As illustrated in fig. 2, the real part of the conductivity is an increasing function of frequency. The increase continues until one reaches the region of frequencies around the maximum jump frequency of the model where the conductivity stabilises. In experiments the conductivity increases until $\omega \approx 10^{12}$ Hz. At these high frequencies the stochastic assumption of hopping models cease to be valid and one enters a region characterised by various resonance effects. At even higher frequencies the conductivity starts decreasing. The stabilisation of fig. 2 predicted by hopping models is seldomly observed in experiments, and this suggests that one should try to eliminate completely all effects of the maximum jump frequency. This philosophy is followed below.

4. THE RANDOM FREE ENERGY BARRIER MODEL

Equipped with the tools of sec. 3 we now address the problem of formulating the simplest possible realistic model for ac conduction in disordered solids. The dc conductivity is usually thermally activated: $\sigma(0) \propto \exp(-\Delta E_{dc}/kT)$. As illustrated in fig. 1, the ac conductivity is much less temperature dependent than $\sigma(0)$, suggesting it is dominated by processes with smaller activation energy than ΔE_{dc} . The value of the ac conductivity activation energy depends on frequency and temperature so it is natural to assume, consistent with the disorder of the solid, that a whole range of activation energies is involved. This idea goes back in time 1946 [29,57] and it was the basic ingredient in Stevels' and Taylor's model from 1957 [20,22]. It should be emphasised that, even without a microscopic picture of the transport mechanism, results as illustrated in fig. 1 strongly suggest that any model for ac conduction should somehow be built on the assumption of a distribution of energy barriers. Hopping models, of course, fit nicely into this since it is realistic to assume the individual quasi-particle jumps to be thermally activated over an energy barrier. More generally, one speaks about free energy barriers [48] and writes

$$\Gamma(\bar{s} \rightarrow \bar{s}') = \Gamma_0 \exp(-\Delta F/kT) \quad (22)$$

where Γ_0 is the attempt frequency and the free energy barrier, $\Delta F = \Delta E - T\Delta S$, is composed of an energy barrier ΔE and an entropy barrier ΔS . Quantum-mechanical tunnelling may be thought of as providing a negative entropy barrier proportional to the

tunnelling distance. Adopting this terminology, it is possible to speak about ionic and electronic conduction in a unified language which, incidently, also covers the possibility of thermally activated electron or polaron hops over energy barriers.

In modelling a disordered solid, the simplest possible assumption is that all free energy barriers are equally likely. Since $p(\Gamma) = p(\Delta F) (d\Delta F/d\Gamma)$ this means that

$$p(\Gamma) \propto \Gamma^{-1}. \quad (23)$$

The model defined by eq. (23) will be referred to as the random free energy barrier model. To solve the model within the CTRW approximation (eq. (17)), the distribution of γ 's needs to be calculated. Since γ is a sum of Γ 's (eq. (8)), $p(\gamma)$ is a convolution of $p(\Gamma)$ with itself a number of times. The result is a complicated function, equal to γ^{-1} times some logarithmic terms. These terms are not very important compared to the γ^{-1} term, so we approximate $p(\gamma)$ simply by γ^{-1} . Substituting this into eq. (17) leads to

$$\sigma(\omega) = \frac{1}{6} \left[-i\omega + \frac{\ln \lambda}{\ln \left(\frac{1 + i\omega/\gamma_{\min}}{1 + i\omega/\gamma_{\max}} \right)} \right] \quad (24)$$

where two cut-off's have been introduced, and $\lambda = \gamma_{\max}/\gamma_{\min}$.

According to the philosophy of sec. 3 any influence of the high-frequency cut-off should be eliminated. In realistic cases $\gamma_{\min} \ll \gamma_{\max}$ implying the second term of eq. (24) dominates. For frequencies $\omega \ll \gamma_{\max}$ we thus have

$$\sigma(\omega) = \frac{1}{6} \frac{i\omega \ln \lambda}{\ln(1 + i\omega\tau)}, \quad \tau = \gamma_{\min}^{-1}, \quad (25)$$

From this expression we get

$$\sigma(0) = \frac{\ln \lambda}{6 \tau} \quad (26)$$

which substituted into eq. (25) finally gives [15]

$$\sigma(\omega) = \sigma(0) \frac{i \omega \tau}{\ln(1 + i \omega \tau)} \quad (27)$$

By regarding this expression as a formula for $\sigma(\omega)$ with two free parameters, $\sigma(0)$ and τ , any influence of γ_{\max} has now been formally eliminated.

The random free energy model predicts a universal shape of $\sigma'(\omega)$ when plotted in the usual log-log plot [15]. In fig. 3 the model is compared to experiments on a number of different solids. Though exact universality is not observed, the model is in rough agreement with experiments. The model implies a high frequency behaviour very close to a power-law, reminding us of the danger of deducing fundamental power-laws from log-log plots. For $10^3 < \omega \tau < 10^6$ one finds $s \approx 0.8$. This offers a possible explanation for the frequently observed exponents around 0.8 [4]. For $\omega \tau \rightarrow \infty$ the exponent s converges slowly to one according to the expression [15]

$$s = 1 - 2 / \ln(\omega \tau) \quad (28)$$

This can be easily proved from $\sigma'(\omega) \propto \omega \tau / \ln^2(\omega \tau)$ which is valid whenever $\omega \tau \gg 1$. In general, the model can explain exponents between 0.7 and 1.0 which is exactly the interval in which one finds the vast majority of reported exponents. Also in

agreement with experiments is the fact that $s(\omega)$ is a weakly increasing function of ω .

For the dielectric loss one finds by substituting eq. (27) into eq. (1)

$$\epsilon''(\omega) = 2 \Delta \epsilon \left[\frac{\text{Arctan}(\omega\tau)}{(\ln\sqrt{1+(\omega\tau)^2})^2 + (\text{Arctan}(\omega\tau))^2} - \frac{1}{\omega\tau} \right] \quad (29)$$

where $\Delta \epsilon$ is the dielectric loss strength which is given by

$$\epsilon_0 \Delta \epsilon = \frac{1}{2} \sigma(0) \tau. \quad (30)$$

Equation (29) implies a very broad loss peak with a temperature independent shape. The loss peak is shown in fig. 4 together with data for a typical sodium silicate glass. There is a qualitative but not exact agreement between theory and experiment. -- Important is the fact that the BNN-relation is satisfied by the model. A numerical analysis of eq. (29) shows that the loss peak frequency is given by $\omega_m \tau = 4.71$ [18]. Combining this with eq. (30) and the definition of the BNN parameter in eq. (3) we get

$$P_{CTRW} = 0.42. \quad (31)$$

This number is not exactly one as in experiments but must still be regarded as close to one in comparison to the many orders of magnitude variations in $\sigma(0)$ and ω_m for the solids where the BNN-relation has been found [26].

Writing eq. (30) in the form

$$\tau = 2 \epsilon_0 \Delta \epsilon / \sigma(0) \quad (32)$$

implies a scaling principle which has recently been discussed by Summerfield [47] and also used by Scher and Lax in their 1973 papers [33]. The scaling principle, which essentially is nothing but the BNN-relation, allows one to plot different experiments onto a mastercurve. One may use either experiments on one solid at different temperatures as illustrated by Pollak and Geballe's original experiments replotted in fig. 5a and a similar figure for measurements by Mansingh and coworkers (fig. 5b), or measurements at the same frequency on different solids assumed to have the same $\Delta \varepsilon$ (fig. 5c).

In connection with the scaling principle we remind that $\Delta \varepsilon$ experimentally varies with temperature according to the Curie law

$$\Delta \varepsilon \propto T^{-1}, \quad (33)$$

a fact which is actually also predicted by the CTRW treatment though it has been hidden by our nationalised unit system. Fig. 6 illustrates the use of the scaling principle in conjunction with eq. (33) for measurements by Long and Balkan on amorphous germanium. Ignoring for a moment the weak temperature dependence of $\Delta \varepsilon$, eq. (32) predicts the universal conductivity curve to be displaced in direction 45° to the $\log(\omega)$ -axis when the temperature is changed. As the temperature is lowered $\sigma(0) \rightarrow 0$, which implies that measurements at a fixed frequency in effect probes larger and larger ωT on the universal conductivity curve. Since $s \rightarrow 1$ as $\omega T \rightarrow \infty$, the model thus predicts $s \rightarrow 1$ as $T \rightarrow 0$ which is in agreement with experiment. Substituting $\sigma(0) \propto \exp(-4F_{dc}/kT)$ via eq. (32) into eq. (28) we find as $T \rightarrow 0$ for the exponent s , measured in a fixed range of frequencies,

$$S = 1 - T/T_0, \quad kT_0 = \frac{1}{2} \Delta E_{dc}. \quad (34)$$

According to the theory, the temperature dependence of the ac conductivity is much weaker than that of the dc conductivity. Note that the temperature dependence vanishes whenever $s=1$. This is predicted and observed for all systems at low temperatures, but $\sigma(\omega)$ may also become temperature independent at room temperature for solids with a very low, perhaps unmeasurable dc conductivity.

In experiments one finds that, while $\sigma(0)$ may vary many orders of magnitude, the ac conductivity varies only relatively little, i. e. one or two orders of magnitude, between quite different solids [2]. This can be understood within the model: For two different solids, 1 and 2, we find from eqs. (27) and (30)

$$\lim_{\omega \rightarrow \infty} \frac{\sigma^{(1)}(\omega)}{\sigma^{(2)}(\omega)} = \frac{\sigma^{(1)}(0) \tau^{(1)}}{\sigma^{(2)}(0) \tau^{(2)}} = \frac{\Delta \epsilon^{(1)}}{\Delta \epsilon^{(2)}}. \quad (35)$$

Since the dielectric loss strength usually varies only little between different solids at ordinary temperatures, eq. (38) explains the relatively little spread in ac conductivity.

Turning now to the problem of solving the random free energy barrier model within the effective medium approximation, we first substitute eq. (21) into eq. (20) and get $\left\langle \frac{\Gamma - \sigma}{\Gamma + \chi \sigma} \right\rangle = 0$ or

$$(1 + \chi) \sigma \left\langle \frac{1}{\Gamma + \chi \sigma} \right\rangle = 1 \quad (36)$$

where

$$\chi = \frac{3}{1 - i\omega \langle 3 | \langle 6 \rangle | 3 \rangle} - 1. \quad (37)$$

It is straightforward to calculate the average appearing in eq. (36) when the distribution of Γ 's is given by eq. (23). The result is

$$(1 + \chi) \ln \left(\frac{\Gamma_{\max} + \chi \sigma}{\Gamma_{\min} + \chi \sigma} \right) = \ln \left(\frac{\Gamma_{\max}}{\Gamma_{\min}} \right) \quad (38)$$

which is a rather complicated equation for $\sigma(\omega)$. According to the philosophy of sec. 3, however, we are only interested in the limit of very large Γ_{\max} . In this limit an important simplification occurs [38]. In the whole range of frequencies much smaller than Γ_{\max} we have $\omega \ll |\sigma(\omega)|$. In this region one may therefore expand χ to first order in $\omega/\sigma(\omega)$:

$$\chi = 2 + i\omega \xi / \sigma(\omega) + \dots \quad (39)$$

where ξ is a numerical constant given by [38, 58]

$$\xi = \frac{1}{6\pi^3} \int_0^\pi \int_0^\pi \int_0^\pi \frac{dx dy dz}{1 - \frac{1}{3}(\cos(x) + \cos(y) + \cos(z))} = 0.253 \quad (40)$$

The expansion in eq. (39) is only possible in three or more dimensions where the Green's function for diffusion is well-behaved as $\omega \rightarrow 0$. Substituting now eq. (39) into eq. (38) for both $\omega = \omega$ and $\omega = 0$ we find, since $\Gamma_{\min} \ll |\sigma(\omega)| \ll \Gamma_{\max}$ (which follows from eq. (38) by putting $\chi = 2$),

$$(3 + i\omega \xi / \sigma(\omega)) \ln \left(\frac{\Gamma_{\max}}{2\sigma(\omega) + i\omega \xi} \right) = 3 \ln \left(\frac{\Gamma_{\max}}{2\sigma(0)} \right) \quad (41)$$

which expanded to first order in $\omega/\sigma(\omega)$ reduces to

$$3 \ln\left(\frac{\sigma(0)}{\sigma(\omega)}\right) + i\omega \frac{\xi}{\sigma(\omega)} \ln\left(\frac{\sigma(0)}{\sigma(\omega)}\right) + i\omega \frac{\xi}{\sigma(\omega)} \ln\left(\frac{\Gamma_{\max}}{2\sigma(0)}\right) - i\omega \frac{3\xi}{2\sigma(\omega)} = 0. \quad (42)$$

The second term is unimportant compared to the first term and may be ignored, leading to

$$\frac{\sigma(\omega)}{\sigma(0)} \ln\left(\frac{\sigma(\omega)}{\sigma(0)}\right) = i\omega \bar{z} \quad (43)$$

where

$$\bar{z} = \frac{\xi}{3\sigma(0)} \left(\ln\left(\frac{\Gamma_{\max}}{2\sigma(0)}\right) - \frac{3}{2} \right). \quad (44)$$

Equation (43) was first derived by Bryksin in 1980 for a model of electrons tunnelling between nearest neighbours in a solid with electron sites randomly located in space [38]. The jump frequency probability distribution of this model is much more complicated than Γ^{-1} , but in the limit $\Gamma_{\max} \rightarrow \infty$ the frequency dependent conductivity is the same in the two models. It is quite unusual that the EMA leads to such a simple and beautiful equation. Equation (38) will henceforth will be referred to as Bryksin's equation.

In fig. 7 the $\sigma'(\omega)$ given by Bryksin's equation is compared to the CTRW solution of the random free energy barrier model (eq. (27)). The solutions are quite similar, lending some credit to the simple CTRW expression for $\sigma(\omega)$. It is easy to show from eq. (43) that, even for the EMA solution, the exponent for the ac conductivity is given by eq. (28) [38]. All features of the CTRW solution are shared by the solution of Bryksin's equation which thus also explains the facts listed at the end of sec. 2. In particular, the RW-approximation is satisfied by the EMA solution

though eq. (30) is now replaced by

$$\epsilon_0 \Delta \epsilon = \sigma(0) \tau \quad (45)$$

The loss peak frequency is given by $\omega_m \tau = 1.709$ so the BNN p -parameter is

$$P_{EMA} = 0.59 \quad (46)$$

This value is in somewhat better agreement with the experimentally found $p \cong 1$ than the $p_{CTRW} = 0.42$. But for other purposes the two solutions are practically identical and one may just as well use eq. (27) as Bryksin's equation which has to be solved numerically before it can be compared to experiments.

5. DISCUSSION

Looking back on the history of ac conduction in disordered solids, it strikes one that a handful of glass technologists very early established the general features of glass ionic conductivity, while, despite extensive research, only much more recently the same features have been acknowledged to be valid also for electronic conductive disordered semiconductors. A likely explanation for this is the fact that electronic conductivity was always thought to be much more complicated than transport in ionic conductive solids, which obviously proceeds via thermally activated charge carrier jumps over barriers. The pair approximation, which seems to have delayed a proper understanding of electronic transport, was never really applied to ionic glasses because one needs also a mechanism for the dc conduction which very early was known to be closely related to the ac conduction. On the other hand, the traditional ion glass researchers never came up with realistic models that can explain both the BNN-relation and the broad dielectric loss peaks [18], and the more successful random walk models were proposed by workers within the semiconductor school. Despite extensive theoretical work, however, these models have not yet become popular among experimentalists. This is perhaps because the models usually end up with complex equations that are far from transparent in their interpretation and have to be solved numerically. It has been the purpose of this paper to show that simple random walk models do exist and to encourage their use.

The justification of hopping models comes from the fact that ac and dc conduction are due to the same mechanism. This is the message of the BNN-relation (eq. (3)) which thus becomes central

to the whole subject. It is of crucial importance that genuine loss peaks are observed. Otherwise, even when ac and dc conduction are totally unrelated, one may find a BNN-like relation of the form $\sigma(\omega) \propto \omega_m$ where ω_m is the characteristic frequency for onset of ac conduction; this is the case e. g. if $\sigma(\omega) = \sigma(\omega) + A\omega$. In experiments one does indeed find loss peaks in all disordered solids, though this is not always as carefully checked as one might wish.

Given that conduction in disordered solids is to be described by hopping models, the only possible explanation for the ion-electron analogy is that the same jump frequency distribution applies for both cases. The simplest guess at this distribution is the one corresponding to randomly varying free energy barriers for jumps, eq. (23). Actually, one may argue for this distribution directly from experimental facts [17]: Since the shape of the $\sigma'(\omega)$ -curve is temperature independent and $s \rightarrow 1$ as $T \rightarrow 0$, it can be concluded that $s \rightarrow 1$ as $\omega T \rightarrow \infty$ on the mastercurve. The conductivity has dimension of frequency and there can be no effect of Γ_{\min} on $\delta(\omega)$ as $\omega \rightarrow \infty$, so $p(\Gamma)$ can contain no constants of dimension and must therefore be proportional to Γ^s . Note also that, at low frequencies when the cut-off at Γ_{\min} starts to play a role, one expects it to decrease the frequency dependence of the conductivity slightly, i. e. to reduce s below one. This is exactly what happens in the random free energy barrier model (eq. (28)).

In hopping models it is possible to distinguish different regions of frequency [38,49]. At low frequencies the conductivity is constant. Here transport takes place on infinite "percolation" paths. Then comes a region of frequencies where the conductivity increases strongly with frequency (compare fig.

2); here transport is dominated by contributions from hopping in finite clusters. Finally comes the region where the high frequency cut-off starts to play a role and $s(\omega)$ decreases to zero with increasing frequency. This is where the pair approximation gradually becomes valid, i. e. where the conductivity is made up of contributions of independent pairs of sites connected by a link with an associated particularly large jump rate. This division into three regions of frequency is suggestive but not really based on exact theory. The validity of the pair approximation at high frequencies is an exact result, though [49]. To estimate where the pair approximation sets in, let us use the distribution of sec. 4 (eq. (23)) which gives equal weight to each decade of jump frequencies. In order for a link to be "isolated" from its surroundings, its jump rate must be larger than the 10 other links it is directly connected to on the cubic lattice. Thus, since the random free energy model weights all decades of jump frequency equally, on the logarithmic frequency axis the pair approximation will only be valid in the final 10% of the interval between Γ_{\min} and Γ_{\max} , and above Γ_{\max} . In order to fit experiments Γ_{\max} must be at least 10^{12} Hz, so the pair approximation is never of relevance at typical laboratory frequencies (unless at very low temperatures), and we may safely follow the philosophy of sec. 3 to eliminate any influence of Γ_{\max} . In the resulting "renormalized" hopping models, all the physics is a consequence of the low-frequency cut-off at Γ_{\min} . This is complementary to the pair approximation where the physics is a consequence of the high-frequency cut-off (eq. (5)) [17].

When applying the renormalization philosophy to the random free energy barrier model, one finds in the CTRW approximation a

simple formula for $\sigma(\omega)$ (eq. (27)) and in the EMA a simple equation for $\sigma(\omega)$ (eq. (43)). As illustrated in fig. 7 these two solutions are almost identical. Since the dc conductivity in the CTRW approximation generally may be wrong by several orders of magnitude [56] while the EMA value is much more accurate, this similarity between the two solutions is far from obvious and must be regarded as an empirical fact. Apparently, the CTRW is saved by our prescription of eliminating Γ_{max} , leaving $\sigma(0)$ as a free parameter in the model. Recently it has been shown by Summerfield that several different models solved in the EPA have almost the same frequency dependence in the region of frequencies where the high-frequency cut-off is irrelevant [47]. He referred to this phenomenon as "quasi-universality". The solutions of the models discussed by him are quite close to the solution of the random free energy barrier model, supporting a hypothesis of "quasi-universality" among all models and not only among EPA models as originally suggested by Summerfield. Though further investigation of this hypothesis is necessary, a preliminary conclusion is that more or less any model in the $\Gamma_{max} \rightarrow \infty$ limit gives the same frequency dependent conductivity. Equation (27) provides a simple analytical representation of this quasi-universal conductivity.

In the limit of $\Gamma_{max} \rightarrow \infty$, the CTRW approximation is represented by the electrical equivalent circuit shown in fig. 8a [16]. In the circuit all capacitances are equal while the resistances vary. The impedance $Z(\omega)$ is given by

$$Z(\omega) = \left\langle \frac{1}{R^{-1} + i\omega C} \right\rangle_R \quad (47)$$

Corresponding to randomly varying free energy barriers, the

resistance probability distribution varies as R^{-1} , the analogue of eq. (23), which implies that the characteristic time $t = RC$ is also distributed according to t^{-1} . If the maximum value of t is denoted by τ we now get

$$Z(\omega) = \frac{K}{C} \int_0^{\tau} \frac{1}{t^{-1} + i\omega} \frac{dt}{t} = \frac{K}{C} \int_0^{\tau} \frac{dt}{1 + i\omega t} \quad (48)$$

Since t^{-1} is not normalizable, the constant K is unknown and must be determined selfconsistently. When this is done after the integration has been carried out, eq. (48) reduces to eq. (27). Note that it is straightforward to actually build the equivalent circuit in the laboratory, since the ordinary resistance scale is logarithmic just as the distribution used in eq. (48).

The physical interpretation of the circuit is not quite obvious. Intuitively, one may argue that the one-dimensional circuit gives a satisfactory representation of conduction in three dimensions because the broad distribution of jump rates implies that conduction is dominated by contributions from certain optimal paths, the "percolation" paths [17]. Usually, however, the circuit of fig. 8a is not related to hopping models but applied to represent conduction in a solid with macroscopic inhomogeneities with different dc resistances [19,59,60]. The idea is that the frequency dispersion of the conductivity is due to a kind of Maxwell-Wagner theory of inhomogeneous dielectrics, as first suggested by Isard [23]. Even in this interpretation, no proper justification has been given for the representation of a three-dimensional solid by a one-dimensional equivalent circuit, and the circuit thus seems to have no direct physical interpretation. Instead, the fact that the one-dimensional solid modelled by the circuit gives a good

description of our three-dimensional reality may be regarded as just another manifestation of quasi-universality.

The equivalent circuit of the renormalized CTRW approximation is complementary to the equivalent circuit of the pair approximation shown in fig. 8b. In the pair approximation conduction takes place in parallel channels corresponding to additive admittances, while in the CTRW case the impedances are additive, intuitively expressing the fact that charge carriers on the percolation paths have to overcome a sequence of barriers.

The random free energy barrier model is essentially identical to Stevels' and Taylor's "random potential energy model" for glass ionic conductivity from 1957 [20,22]. Their model was never generally accepted because it was thought to contradict experiment on two important points [7,8,14]: It was thought that a model based on a distribution of energy barriers can never give temperature independent loss peaks, and also that the BNN-relation implies that ion jumps contributing to the ac conductivity have the same activation energy as those behind dc conduction. These objections are incorrect, however [18]. If all barriers are equally likely, the jump frequency distribution is proportional to ρ^{-1} at all temperatures yielding temperature independent loss peaks. And there is absolutely no problem in having a whole range of activation energies involved in the conduction process. Actually, from figures like fig. 1 and fig. 6 one can conclude that ac conduction indeed must have a smaller activation energy than dc conduction, forcing one to base any theory on a distribution of energy barriers where the dc conductivity activation energy is then the maximum activation energy involved in the conduction process. Correspondingly, the loss peak frequency, which marks the onset of ac conduction, is

essentially the minimum jump rate in the solid: On a time scale larger than ω_m^{-1} the conductivity is frequency independent so the solid "looks" homogeneous to the quasi-particles. This can only come about if ω_m is the minimum effective jump frequency so that many jumps necessarily are involved for times $\gg \omega_m^{-1}$. Since both dc conduction and loss peak frequency are thus determined by the maximum energy barriers, the proportionality between $\sigma(\omega)$ and ω_m in the BNN-relation becomes obvious.

The random free energy barrier model predicts a frequency dependence of σ very close to a power law (fig. 3). This may seem surprising since there is no fundamental power law hidden in eq. (27), but it just provides an illustration of the old truth that "anything is a straight line in a log-log plot". Because of this, one cannot deduce fundamental power laws from apparently straight lines in log-log plots. On the other hand, it may still be convenient to discuss measurements and theory in terms of the "exponent" s .

At the end of sec. 2 we listed in eight points the universally found experimental facts on ac conduction in disordered solids. In sec. 4 it was shown that the random free energy barrier model explains all these facts. Here we just want to point out that these facts are not really independent but closely interrelated, as becomes evident when the facts are discussed in light of the model. The fact that $\sigma'(\omega)$ has a temperature independent shape implies that, at lowering the temperature, one measures further and further out on the master curve. Consequently, since $s(\omega) \rightarrow 1$ as $\omega T \rightarrow \infty$, the exponent s measured in a fixed range of frequencies converges to one as $T \rightarrow 0$. Also, the BNN-relation implies that $\sigma(\omega)$ and ω_m are proportional apart from the factor of T in ΔE (eq. (33)). If

the temperature is lowered, the conductivity curve is therefore displaced in direction 45° to the x-axis in the log-log plot. It is now obvious that the ac conductivity is less temperature dependent than the dc conductivity and for exponents very close to one the ac conductivity must be practically temperature independent. In particular, this is always the case at low temperatures.

The BNN-relation implies a convenient scaling principle which allows one to construct the mastercurve from measurements at different temperatures at a fixed frequency. Closely related to the scaling principle is the fact that the whole of $\sigma(\omega)$ is determined from the two numbers $\sigma(0)$ and $\Delta \varepsilon$ (eq. (30) or (45)). Experimentally, $\Delta \varepsilon$ is usually not very far from one so it is possible to get a rough idea of $\sigma(\omega)$ just from a knowledge of the dc conductivity: Putting $\Delta \varepsilon \approx 1$ in eq. (30) we get $\tau \approx \varepsilon_0 / \sigma(0)$ which, when substituted into eq. (27), gives us $\sigma(\omega)$. At large frequencies, in particular, eq. (27) implies $\sigma'(\omega) \approx \sigma(0) \frac{\omega \tau}{\ln^2(\omega \tau)}$ so a rough estimate of $\sigma'(\omega)$ is

$$\sigma'(\omega) \approx \frac{\varepsilon_0 \omega}{\ln^2(\omega \varepsilon_0 / \sigma(0))} \quad (49)$$

To summarise the present paper, an important point is the irrelevance of Γ_{\max} for $\sigma(\omega)$ in realistic situations. Letting Γ_{\max} go to infinity, one arrives at "renormalized" hopping models for which the pair approximation never becomes valid at high frequencies. Actually, the pair approximation is complementary to the renormalized CTRW approximation as illustrated in fig. 8. The frequency dependent conductivity of the random free energy barrier model is quite similar to that of a number of models discussed by Summerfield [47]. This supports his hypothesis of

quasi-universality: All models based on broad jump frequency distributions yield almost identical $\sigma(\omega)$ in the $\Gamma_{\max} \rightarrow \infty$ limit. Thus it may be concluded that equation (27) is representative for many models. This equation is in reasonable agreement with experiment. It seems, however, that the spread among experiments is somewhat larger than among theories and one cannot really say quasi-universality applies to experiments. More work has to be done to explain this. On account of the quasi-universality among the simple hopping models described by eq. (7), it seems reasonable to assume that the linearized models are too simple and interactions have to be taken into account, including, of course, that due to fermi statistics.

The fact that all disordered solids have similar ac properties means that only little can be learnt about a solid from measuring its frequency dependent conductivity [31,47,61]. At least, this is the case today with the present simple linear hopping theories. Pollak and Pike have suggested that details of any particular conduction mechanism should be contained in deviations from linearity in the frequency dependence, i. e. from $s=1$ [61]. But as is clear from the model discussed in this paper, there are significant deviations from linearity ten or more decades above the loss peak frequency, which are solely a consequence of the low frequency cut-off and provide no important microscopic information. We rather suggest that details of any particular conduction mechanism in principle could be inferred from deviations from eq. (27) which may be regarded as a zeroth order approximation to reality. But, as mentioned already, more theoretical work is needed before microscopic details can be inferred from measured $\sigma(\omega)$.

As regards the question of the best way to present data we

recommend the use of $\sigma(\omega)$. The conductivity is fundamental, being directly related to the equilibrium current-current fluctuations. The use of the frequency dependent dielectric constant has one virtue, though, namely that it reveals loss peaks, the existence of which is crucial to prove that dc and ac conduction are indeed due to the same mechanism. The very popular electric modulus is not recommended because this quantity mixes in effects of ϵ_{∞} which, if the ideas advanced here are correct, are independent of and not related to the ac conductivity. In the present approach, the total admittance is a sum of a hopping contribution and a purely imaginary dielectric contribution from the atomic polarisability (fig. 9).

Finally, we would like to emphasise again that an understanding of ac conduction and its relation to dc conduction is important, even if one is only interested in steady state transport properties like dc conductivity, Hall resistance, thermopower, etc. From the present paper it seems it can be safely concluded that a whole distribution of energy barriers is involved in dc transport. Theories that do not take this into account are necessarily incomplete.

ACKNOWLEDGEMENT

The author would like to thank N B Olsen, P V Christiansen, T Christensen, P Viscor, and A R Long for many fruitful discussions on ac conduction during the last few years. The present work was supported by the Danish Natural Science Research Council.

REFERENCES

1. A R Long, Adv. Phys. 31 (1982) 553.
2. A K Jonscher, Nature 267 (1977) 673.
3. A E Owen, J. Non-Cryst. Solids 25 (1977) 372.
4. N F Mott and E A Davis, "Electronic Processes in Non-Crystalline Materials" (Clarendon Press, Oxford, 1971).
5. A Mansingh, Bull. Mater. Sci. (India) 2 (1980) 325.
6. A E Owen, in: "Progress in Ceramic Science", Vol. 3, ed. J E Burke (The Macmillan Company, New York, 1963), p. 77.
7. D Ravaine and J L Souquet, in: "Solid Electrolytes", eds. P Hagenmuller and W Van Gool (Academic Press, New York, 1978), p. 277.
8. M Tomozawa, in: "Treatise on Materials Science", Vol. 12, ed. M Tomozawa (Academic Press, New York, 1977), p. 283.
9. A R Blythe, "Electrical Properties of Polymers" (Cambridge University Press, London, 1979).
10. I D Raistrick Solid State Ionics 18-19 (1986) 40.
11. M A Careem and A K Jonscher, Phil. Mag. 35 (1977) 1489.
12. M Suzuki, J. Phys. Chem. Solids 41 (1980) 1253.
13. M Pollak and T H Geballe, Phys. Rev. 122 (1961) 1742.
14. J O Isard, J. Non-Cryst. Solids 4 (1970) 357.
15. J C Dyre, Phys. Lett. 108A (1985) 457.
16. J C Dyre, J. Physique Colloq. 46 (1985) C8-343.
17. J C Dyre, IMFUFA text no. 97 (Univ. of Roskilde, 1985).
18. J C Dyre, J. Non-Cryst. Solids 88 (1986) 271.
19. P E Macedo, C T Moynihan, and R Bose, Phys. Chem. Glasses 31 (1978) 171.
20. H Vogel, in: "Handbuch der Physik", Vol. 20, ed. S

- Flügge (Springer-Verlag, Berlin, 1957), p. 350.
21. J M Stevels, J. Physique Colloq. 46 (1985) C8-613.
 22. H E Taylor, J. Soc. Glass Tech. 41 (1957) 350T, 43 (1959) 124T.
 23. J O Isard, Proc. Inst. Elec. Eng. 109B (1962) Suppl. No. 22 p. 440.
 24. J L Barton, Verres Réfr. 20 (1966) 328.
 25. T Nakajima, in: "1971 Annual Report, Conference on Electric Insulation and Dielectric Phenomena" (National Academy of Sciences, Washington DC, 1972), p. 168.
 26. H Namikawa, J. Non-Cryst. Solids 18 (1975) 173.
 27. A Mansingh, J M Reyes, and M Sayer, J. Non-Cryst. Solids 7 (1972) 12.
 28. A R Long, J McMillan, N Balkan, and S Summerfield, Phil. Mag. B, to appear.
 29. C G Garton, Trans. Farad. Soc. 42 (1946) "General Discussion on Dielectrics", p. 56.
 30. I G Austin and N F Mott, Adv. Phys. 18 (1969) 41.
 31. R M Hill and A K Jonscher, J. Non-Cryst. Solids 32 (1979) 53.
 32. S R Elliott, Phil. Mag. 36 (1977) 1291.
 33. H Scher and M Lax, Phys. Rev. B 7 (1973) 4491, 4502.
 34. A Miller and E Abrahams, Phys. Rev. 120 (1960) 745.
 35. E W Montroll and G H Weiss, J. Math. Phys. 6 (1965) 167.
 36. J M Ziman, "Models of Disorder" (Cambridge University Press, Cambridge, 1979).
 37. F Yonezawa, in: "The Structure and Properties of Matter", ed. T Matsubara (Springer-Verlag, Berlin, 1982), p. 383.
 38. V V Bryksin, Sov. Phys. Solid State 22 (1980) 1421.
 39. S Summerfield, Solid State Commun. 39 (1981) 401.

40. B Movaghar and W Schirmacher, *J. Phys. C* 14 (1981) 859.
41. T Odagaki and M Lax, *Phys. Rev. B* 24 (1981) 5284.
42. G E Pike, *Phys. Rev. B* 6 (1972) 1572.
43. S Summerfield and P N Butcher, *J. Phys. C* 15 (1982) 7003.
44. R M Hill and A K Jonscher, *Cont. Phys.* 24 (1983) 75.
45. K L Ngai and C T White, *Phys. Rev. B* 20 (1979) 2475.
46. R Kubo, *J. Phys. Soc. Japan* 12 (1957) 570.
47. S Summerfield, *Phil. Mag.* B 52 (1985) 9.
48. S Glasstone, K J Laidler, and H Eyring, "The Theory of Rate Processes" (McGraw-Hill Book Co., New York, 1941).
49. H Böttger and V V Bryksin, "Hopping Conduction in Solids" (Akademie-Verlag, Berlin, 1985).
50. B I Shklovskii and A L Efros, "Electronic Properties of Doped Semiconductors" (Springer-Verlag, Berlin, 1984).
51. J C Kimball and L W Adams, *Phys. Rev. B* 18 (1978) 5851.
52. M Lax and T Odagaki, in: "Macroscopic Properties of Disordered Media", ed. R Burridge (Springer-Verlag, Berlin, 1982), p. 148.
53. J Klafter and R Silbey, *Surface Sci.* 92 (1980) 393.
54. J K E Tunaley, *Phys. Rev. Lett.* 33 (1974) 1037.
55. J C Dyre, *J. Phys. C*, in the press.
56. P N Butcher, *J. Phys. C* 7 (1974) 2645.
57. M Gevers and F K Du Pré, *Trans. Farad. Soc.* 42 (1946) "General Discussion on Dielectrics", p. 47.
58. M Lax, *Phys. Rev.* 97 (1955) 629.
59. R Stumpe, *Phys. Stat. Sol. (a)* 88 (1985) 315.
60. A Y Vinnikov and A M Meshkov, *Sov. Phys. Solid State* 27 (1985) 1159.
61. M Pollak and G E Pike, *Phys. Rev. Lett.* 28 (1972) 1449.
62. E B Ivkin and B T Kolomiets, *J. Non-Cryst. Solids* 3 (1970)

- 41.
63. F S Howell, R A Bose, P B Macedo, and C T Moynihan, J. Phys. Chem. 78 (1974) 639.
64. I M Hodge and C A Angell, J. Chem. Phys. 67 (1977) 1647.
65. L Murawski, J. Non-Cryst. Solids 90 (1987) 629.
66. A P Bhatt, W A Anderson, and P Ehrlich, Solid State Commun. 47 (1983) 997.
67. H M Kizilyalli and P R Mason, Phys. Stat. Sol. (a) 36 (1976) 499.
68. A Mansingh, R P Tandon, and J K Vaid, Phys. Rev. B 21 (1980) 4829.
69. M Sayer, A Mansingh, J M Reyes, and G Rosenblatt, J. Appl. Phys. 42 (1971) 2857.
70. E A Davis and N F Mott, Phil. Mag. 22 (1970) 903.
71. A R Long and N B Balkan, J. Non-Cryst. Solids 35-36 (1980) 415.

FIGURE CAPTIONS

Fig. 1: Typical observations of the frequency dependent conductivity in a disordered solid at three different temperatures $T_1 < T_2 < T_3$. At low frequencies the conductivity is constant and equal to the dc conductivity, while at higher frequencies the conductivity obeys an approximate power law. The characteristic frequency marking the onset of ac conduction, the dielectric loss peak frequency ω_m , increases with increasing temperature. Note that, in this logarithmic plot, the ac conductivity is less temperature dependent than the dc conductivity.

Fig. 2: Typical behaviour of $\sigma'(\omega)$ in a hopping model. In hopping models $\sigma'(\omega)$ is always an increasing function of frequency [51]. The saturation of $\sigma'(\omega)$ at high frequencies takes place when ω is close to the maximum jump frequency Γ_{max} . Only in this region, typically close to 10^{12} Hz, is the pair approximation valid. At low frequencies, the onset of ac conduction takes place around the loss peak frequency ω_m . This is the lowest effective jump frequency of the system, which corresponds to the longest waiting time at a lattice site. Generally one expects $\omega_m \gg \Gamma_{min}$ since Γ_{min} is the lowest jump frequency of any link between two sites.

Fig. 3: The CTRW solution of the random free energy barrier model (eq. (27)) compared to experiment on a number of different solids (fig. 3a is reproduced from ref. 15). The data represent conduction in: (a): n-doped crystalline silicon (X), sputtered films of arsenic (•), sodium silicate glasses (⊙), glow

discharge silicon (Δ), silicon monoxide ($+$), amorphous germanium (\square), $Mn_{1.8}Ni_{0.6}Co_{0.6}O_4$ (∇), monolayer of stearic acid (\circ); and (b): α - As_2Se_3 at 370 K (\times) [62], viscous $0.4Ca(NO_3)_2 - 0.6KNO_3$ at 338.5 K (\bullet) [63], viscous $HZnCl_3 \cdot 4H_2O$ at 154.5 K (\odot) [64], illuminated polycrystalline zinc oxide (Δ) [60], vanadium phosphate glass at 167 K ($+$) [65], AsF_5 doped polyphenylacetate at 271 K (\square) [66], flux-grown single crystal alumina in c-direction at 873 K (∇) [67], 81% tungsten phosphate glass at room temperature (\circ) [68]. For all data the characteristic time τ has been adjusted to fit the theory as well as possible (τ varies between 10^3 and 10^{-7} sec.).

Fig. 4: The dielectric loss peak of the random free energy barrier model according to eq. (27) and data for a typical sodium-silicate glass (reproduced from ref. 18). The dashed curve is the Debye dielectric loss peak. There is a qualitative, but not exact, agreement between theory and experiment, which is satisfactory in view of the simplicity of the model.

Fig. 5: Applications of the scaling principle of eq. (32) which is essentially nothing but the BNN-relation. In fig. 5a and in fig. 5b data for a single sample at different frequencies and temperatures are plotted, taking advantage of eq. (32) and the Curie law eq. (33). The data are compared to the CTRW solution of the random free energy barrier model (eq. (27)). Fig. 5a considers the original data by Pollak and Geballe on heavily n-doped crystalline silicon at low temperatures, taken from fig. 5 of ref. 13. The data was obtained at the following temperatures: 2 K, 2.5 K, 3 K, 3.5 K, 4.5 K, 5.5 K, at the following frequencies: 0.1 kHz (Δ), 1 kHz (\circ), 10 kHz ($+$),

100 kHz (X). Fig. 5b considers data on a vanadium phosphate glass taken from fig. 2 of ref. 69. The data was obtained at 83 K, 100 K, 125 K, 167 K, 250 K, at 0.1 kHz (□), 1 kHz (▽), 10 kHz (Δ), 100 kHz (○), 8 MHz (+), 3.6 GHz (X). The gigahertz data deviates from the mastercurve, signalling a breakdown of the theory at very high frequencies. In both fig. 5a and fig. 5b the constant C is a fitting parameter: $C = 1.9 \cdot 10^{-12}$ for fig. 5a and $C = 2.1 \cdot 10^{-10}$ for fig. 5b in units of $(\text{Åcm})^{-1} \text{K/Hz}$. -- In fig. 5c data for different chalcogenide glasses are plotted onto a master curve and compared to eq. (27) by assuming the different samples have the same dielectric loss strength $\Delta \epsilon$ which becomes a fitting parameter ($\Delta \epsilon = 0.6$). The data were obtained at 300 K by several workers, see the references of ref. 70 by Davis and Mott who compiled the data.

Fig. 6: Comparison between the prediction of eq. (27) and measurements on amorphous germanium at various temperatures by Long and Balkan [71] (reproduced from ref. 15). The data was fitted by eq. (27) at 77 K and then displaced according to the scaling law of eq. (32) taking account of eq. (33). At the two lowest temperatures the dc conductivity is unknown and was treated as a fitting parameter.

Fig. 7: Comparison between the CTRW and the EMA solution of the random free energy barrier model. The full curve is the CTRW solution (eq. (27)) and the dots mark the EMA solution (eq. (41)). The two solutions are shown for the same value of $G(0)$ and $\Delta \epsilon$ which, according to eqs. (30) and (45), implies $\tau_{\text{EMA}} = 2\tau_{\text{CTRW}}$. The CTRW and EMA solutions are almost indistinguishable, lending credit to the simpler CTRW approach from the more reliable but

also more involved EMA.

Fig. 8: Electrical equivalent circuits for (a) the pair approximation, and (b) the CTRW approximation in the $\Gamma_{max} \rightarrow \infty$ limit. Note that the pair approximation does not have any dc conduction. This figure shows that the two approaches are complementary. This is also reflected by the fact that the exponent s in the pair approximation is a function of the logarithmic distance from ω to the high frequency cut-off (eq. (5)), while s in the CTRW case is a function of the logarithmic distance to the effective low frequency cut-off at ω_m (eq. (28)).

Fig. 9: Total admittance for a semiconducting disordered solid according to hopping models. The admittance is a sum of the hopping contribution discussed in the present paper, and a totally unrelated purely imaginary contribution from the atomic polarisability given by the high frequency dielectric constant ϵ_{∞} . If this picture is correct, the use of the electric modulus in representing data is inconvenient, since it mixes in effects of ϵ_{∞} that are independent of and unrelated to the hopping admittance.

$\log \sigma'(\omega)$

Fig 1

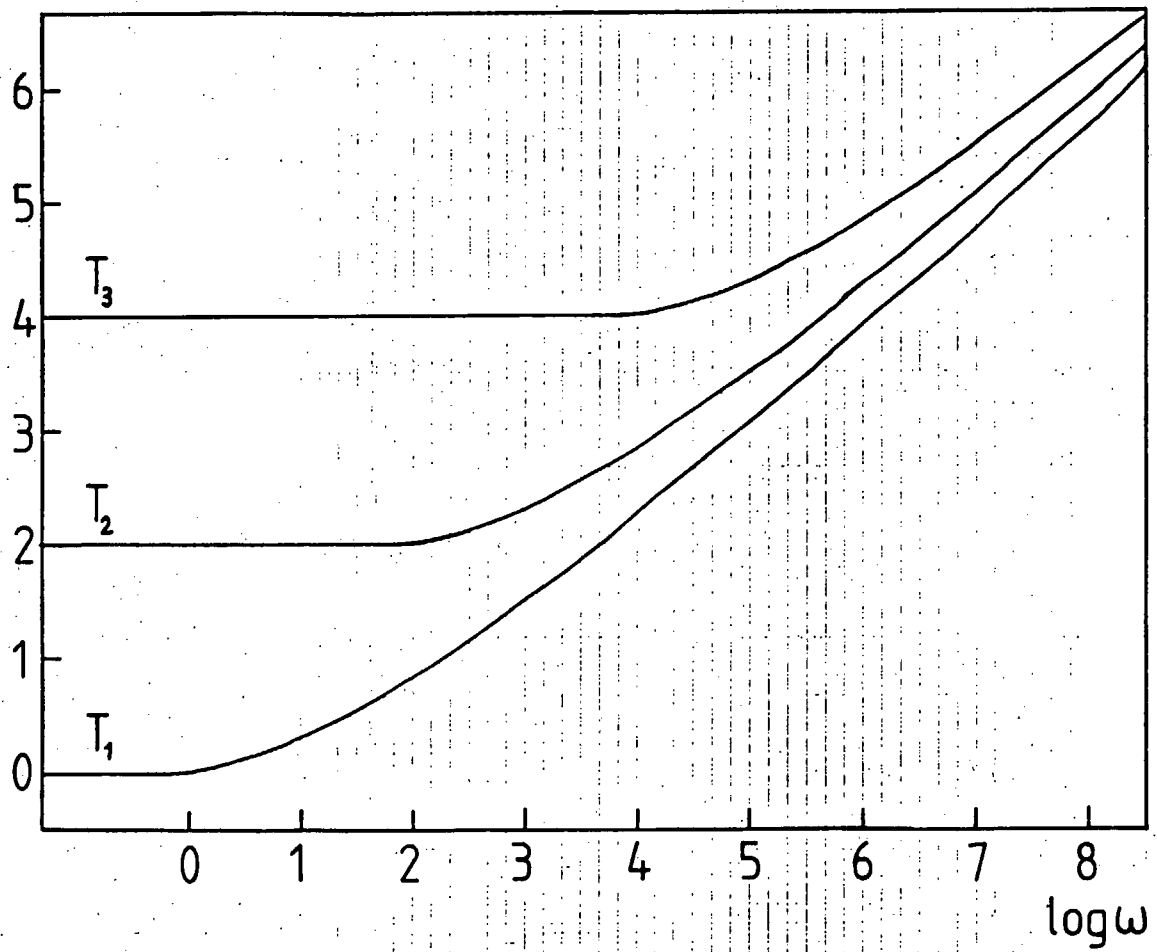

$\log(\sigma'(\omega))$

Fig 2

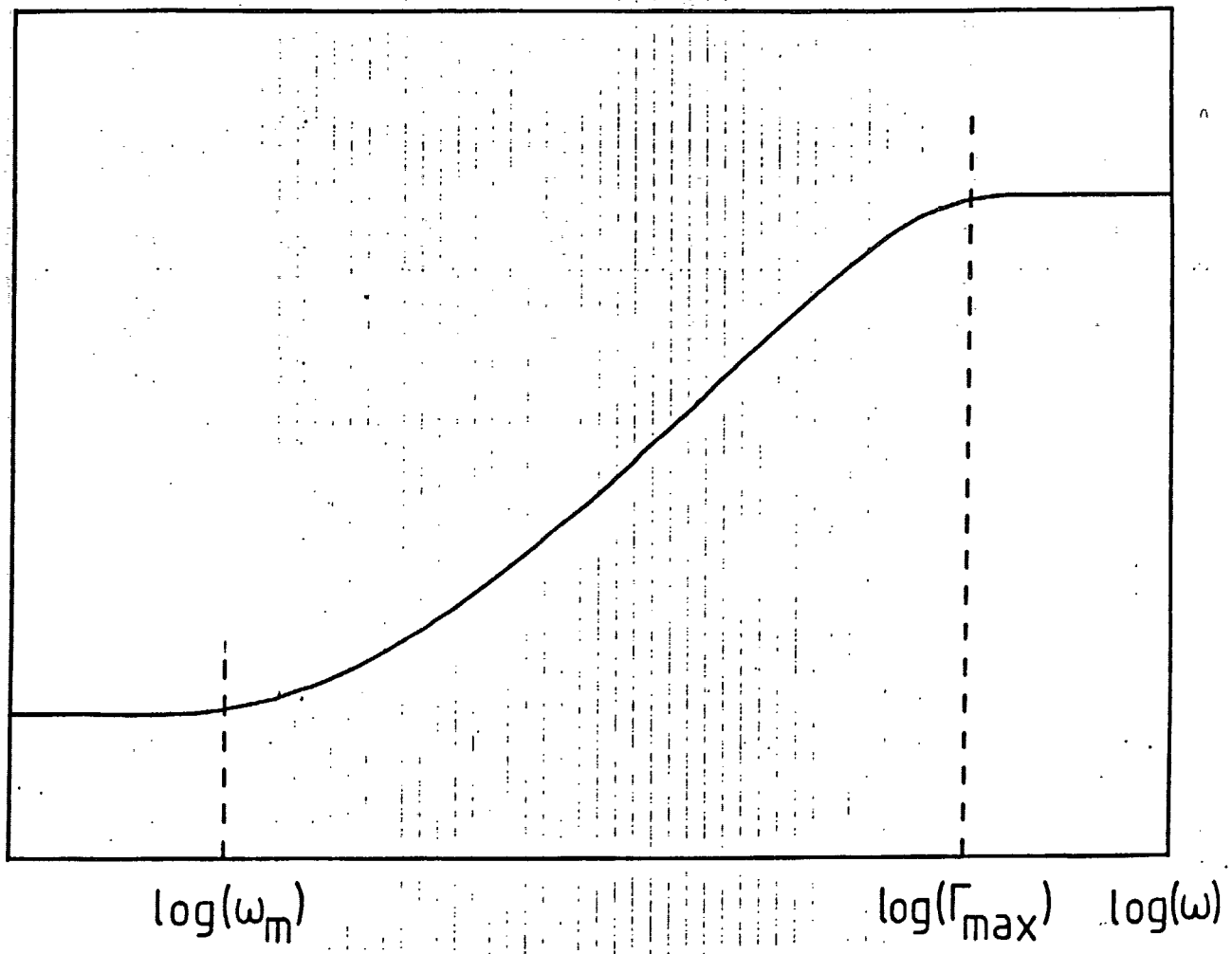

Fig 3a

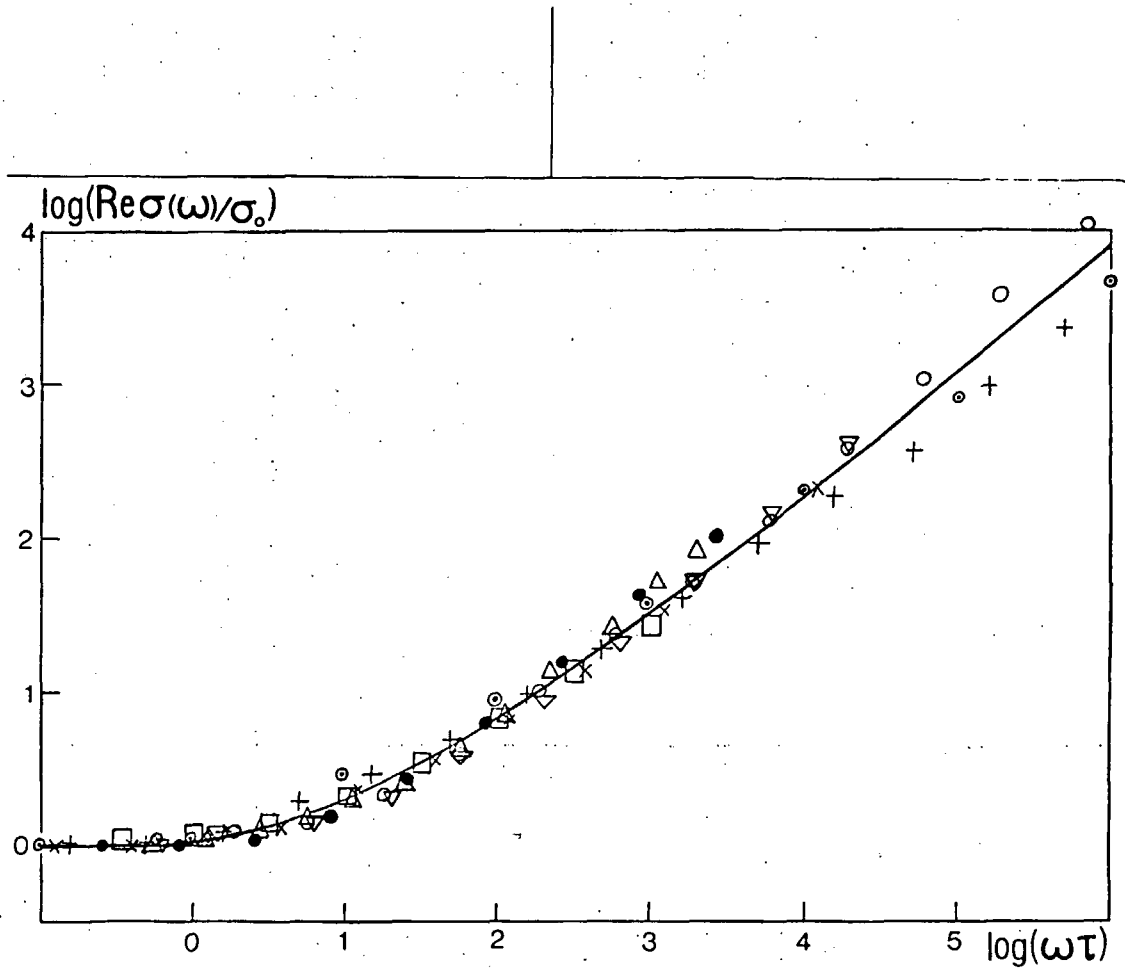

Fig 3b

$\log(\sigma'(\omega)/\sigma(0))$

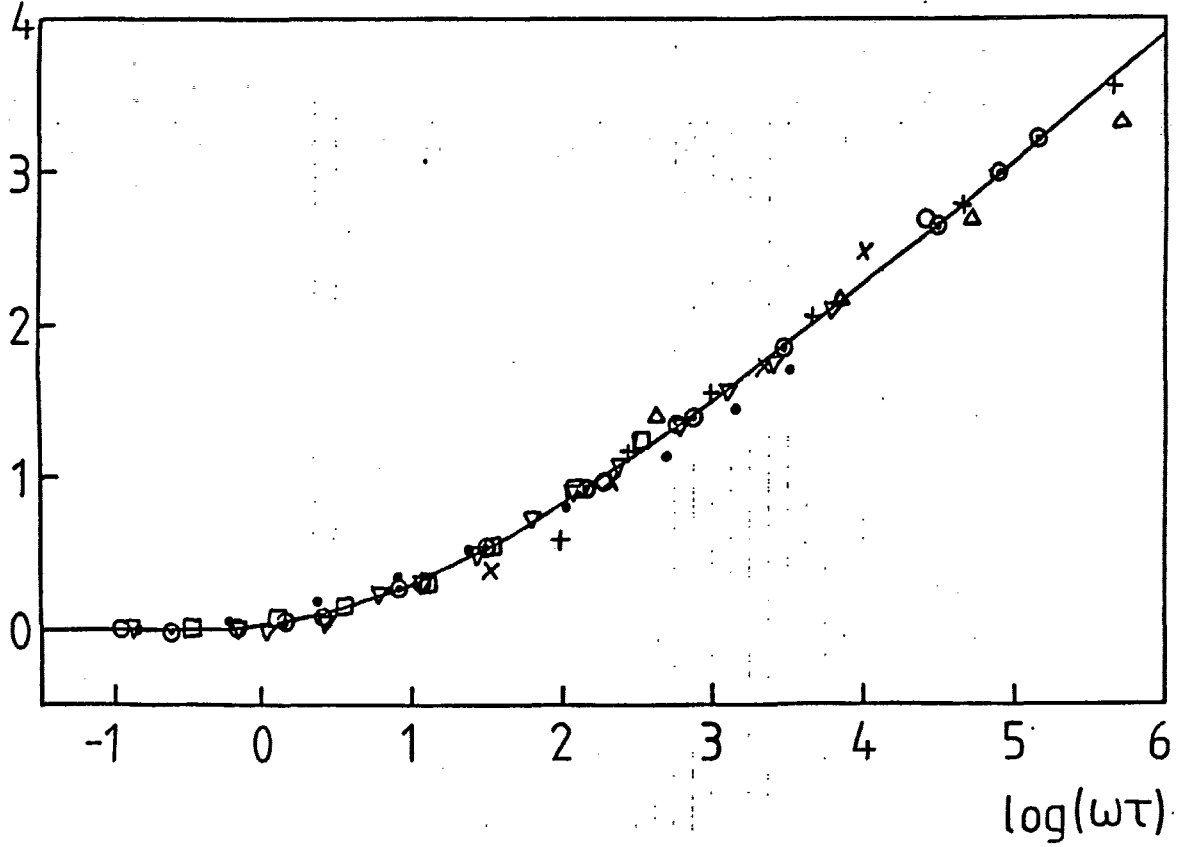

Fig 4

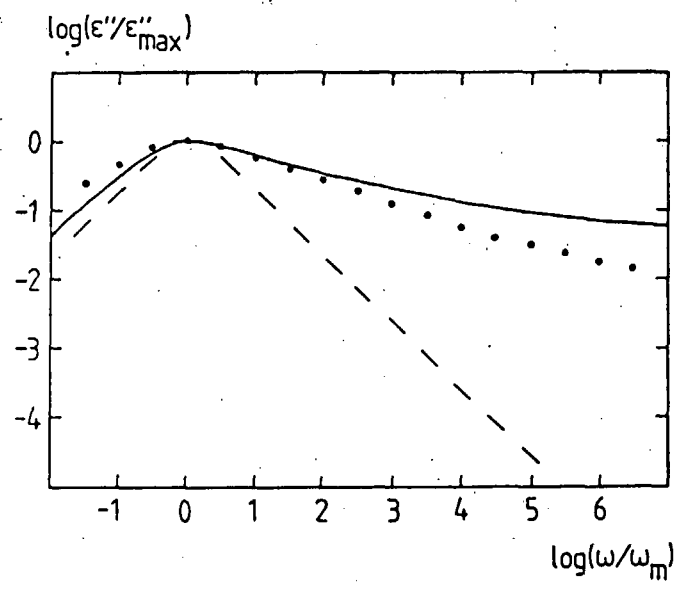

Fig 5a

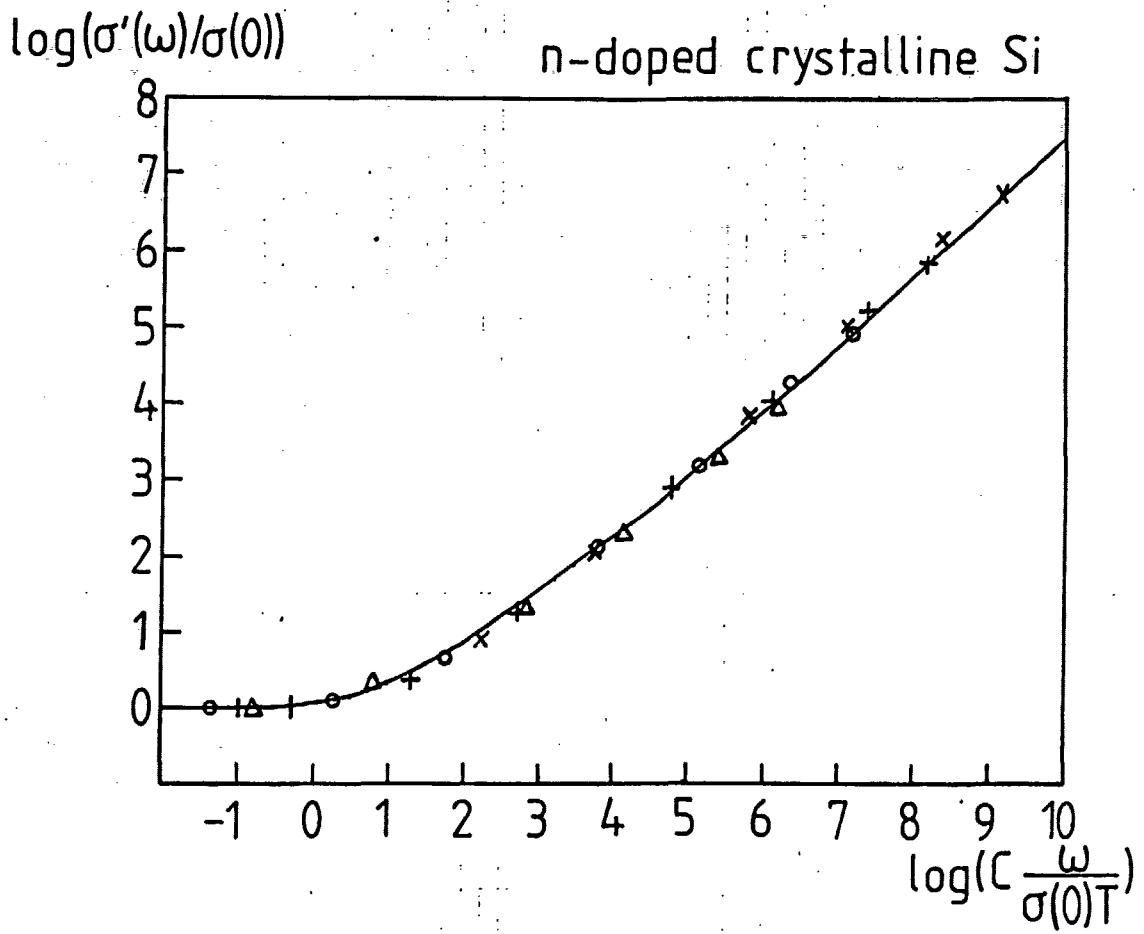

Fig 5b

$\log(\sigma'(\omega)/\sigma(0))$

$V_2O_5 - P_2O_5$

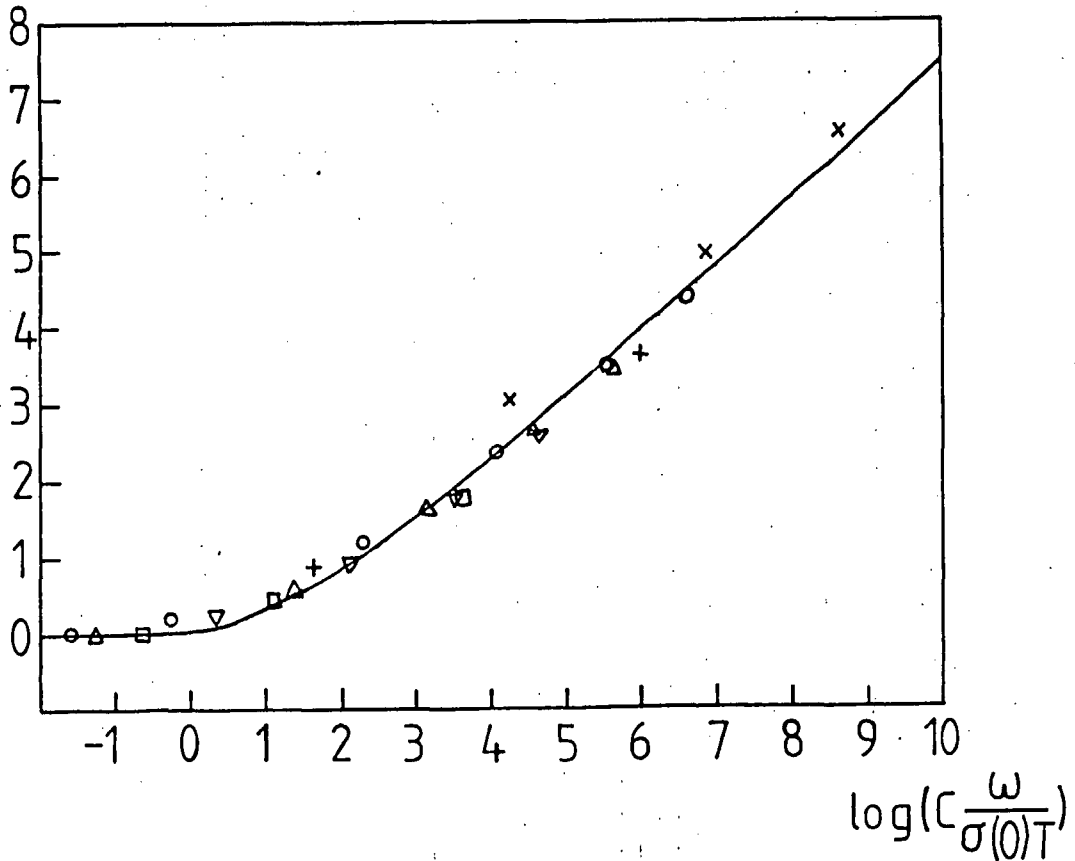

Fig 5c

$$\log \left(\frac{\text{Re } \sigma(\omega = 10^6 \text{ Hz})}{\sigma(0)} \right)$$

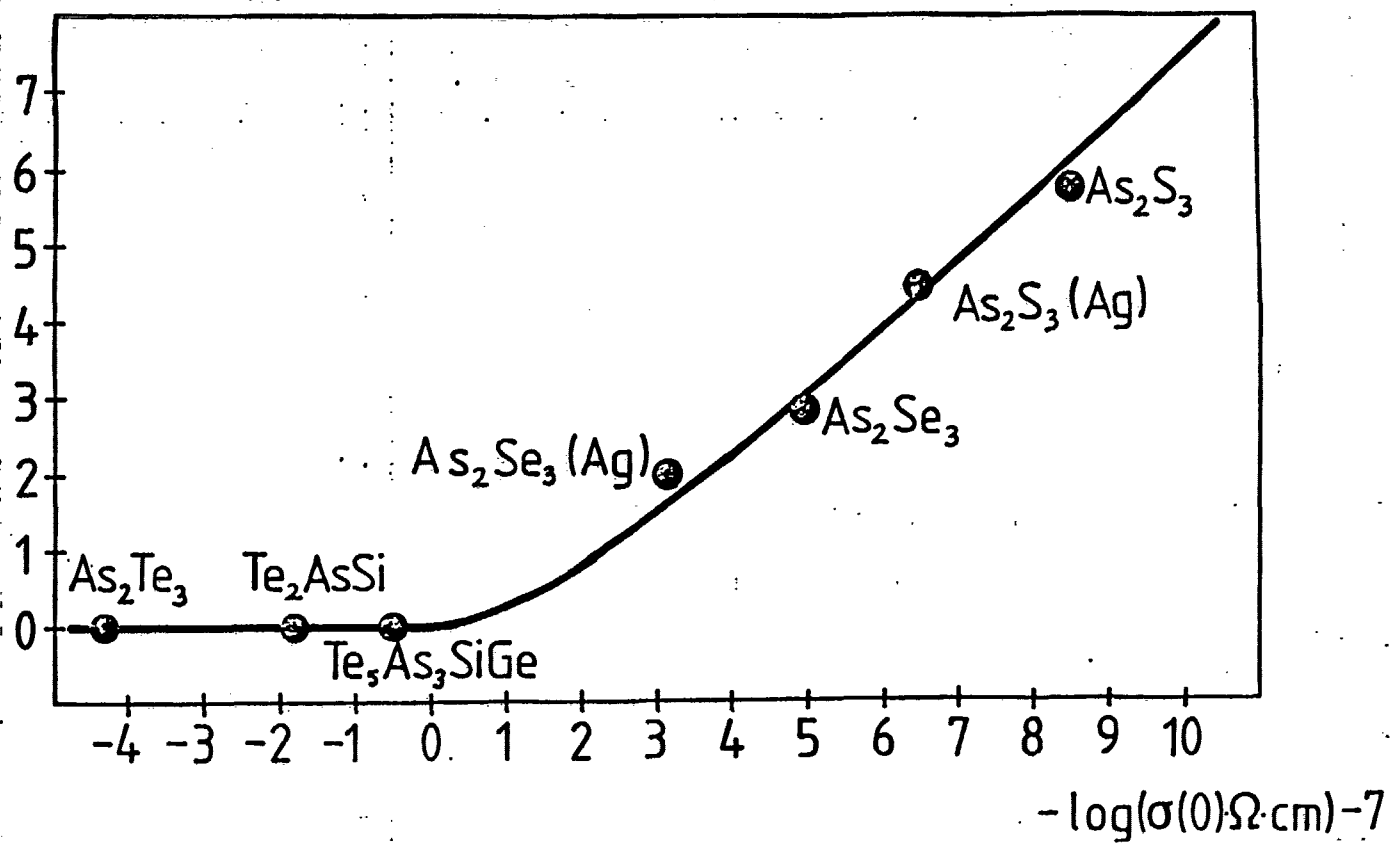

Fig 6

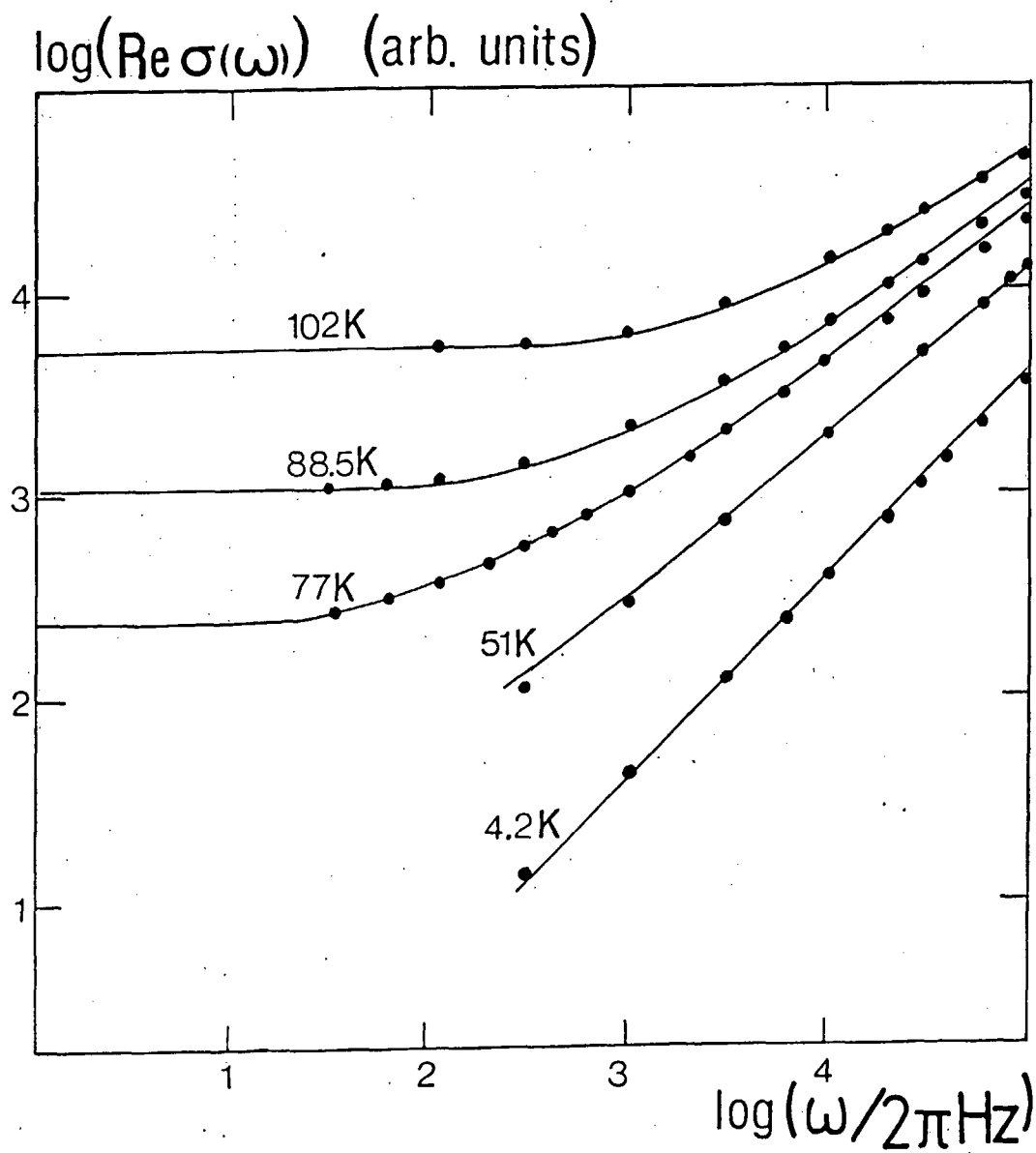

Fig. 7

$\log(\sigma'(\omega)/\sigma(0))$

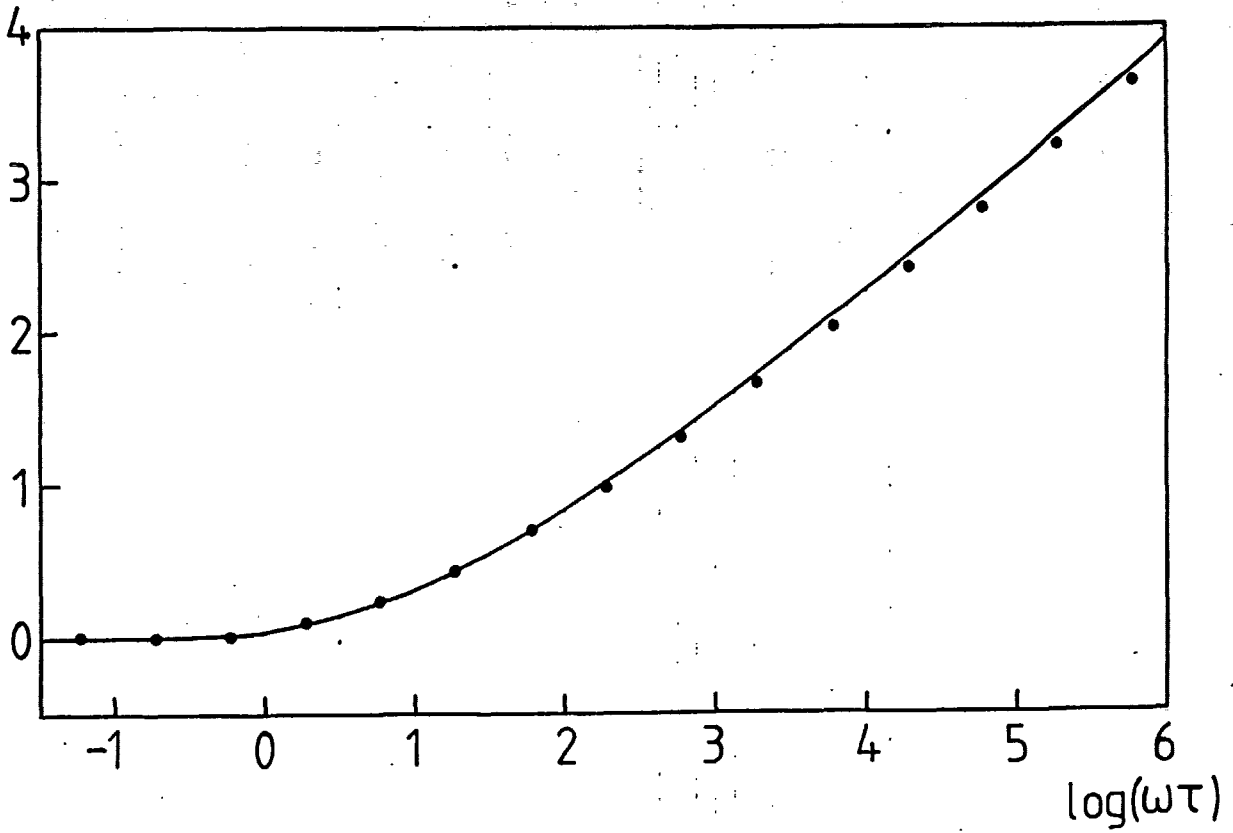

Fig 8a

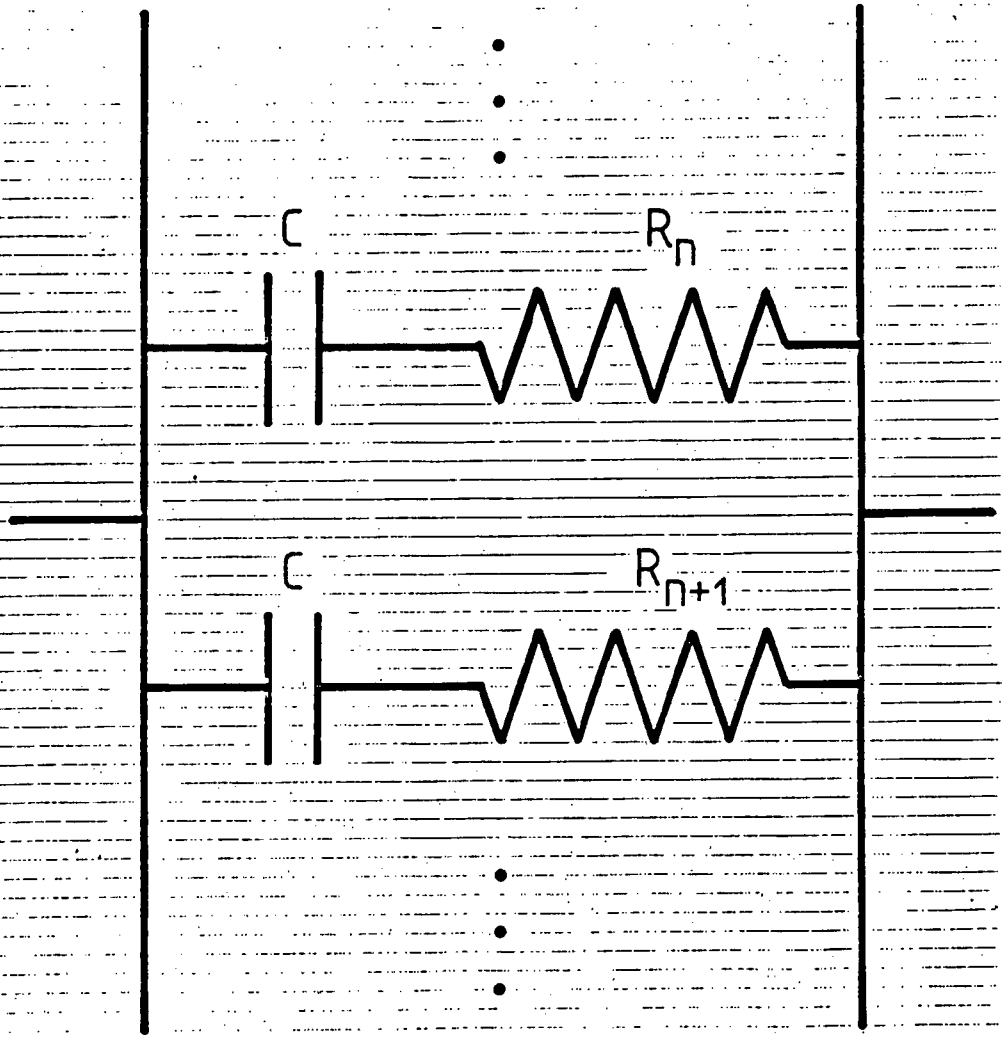

Fig 8b

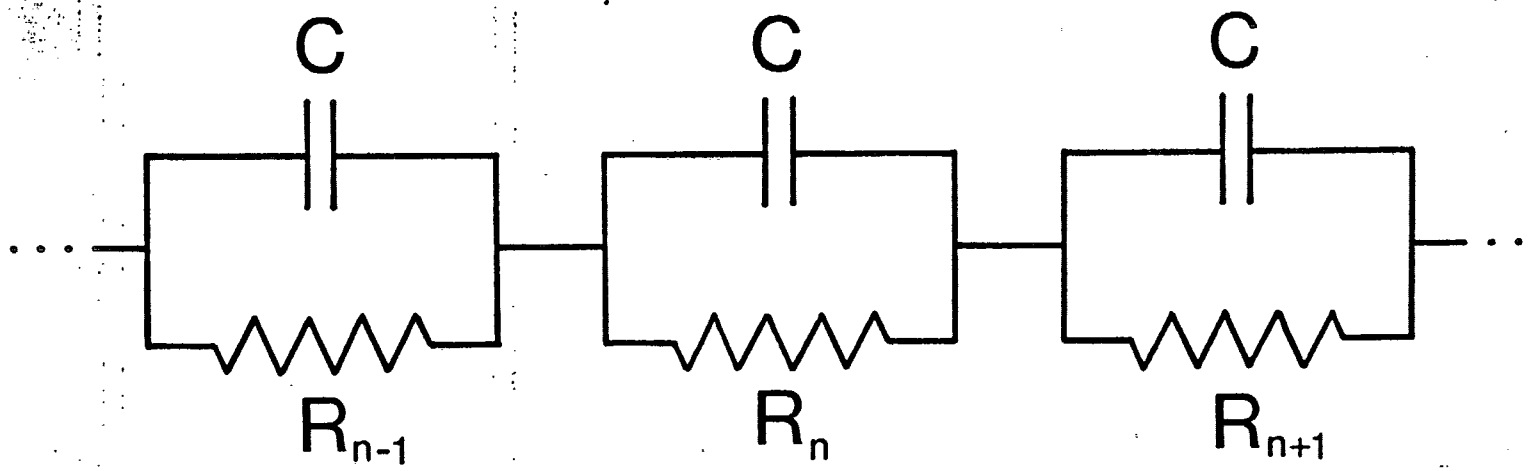
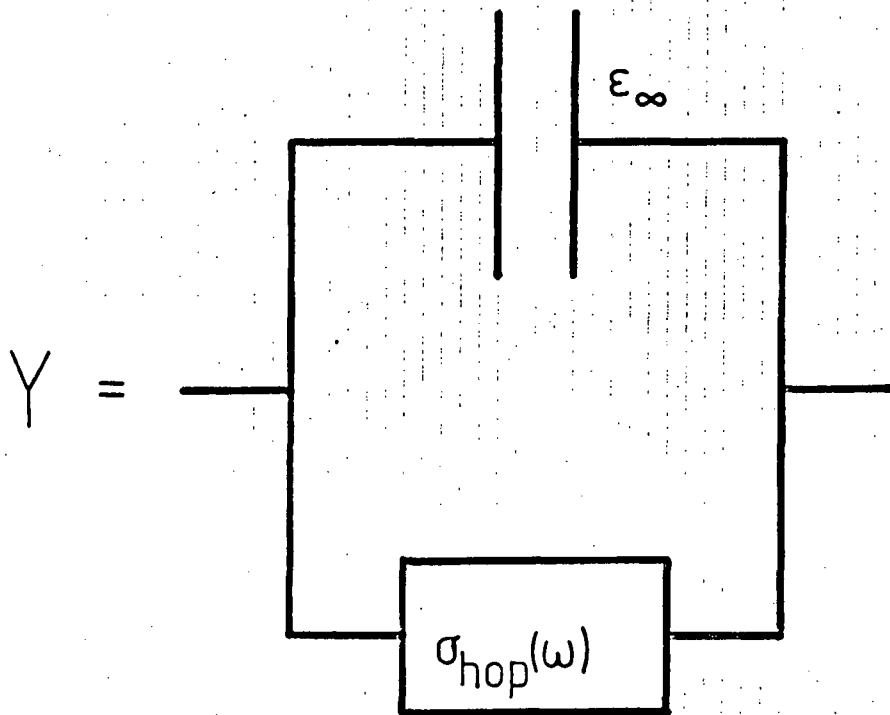
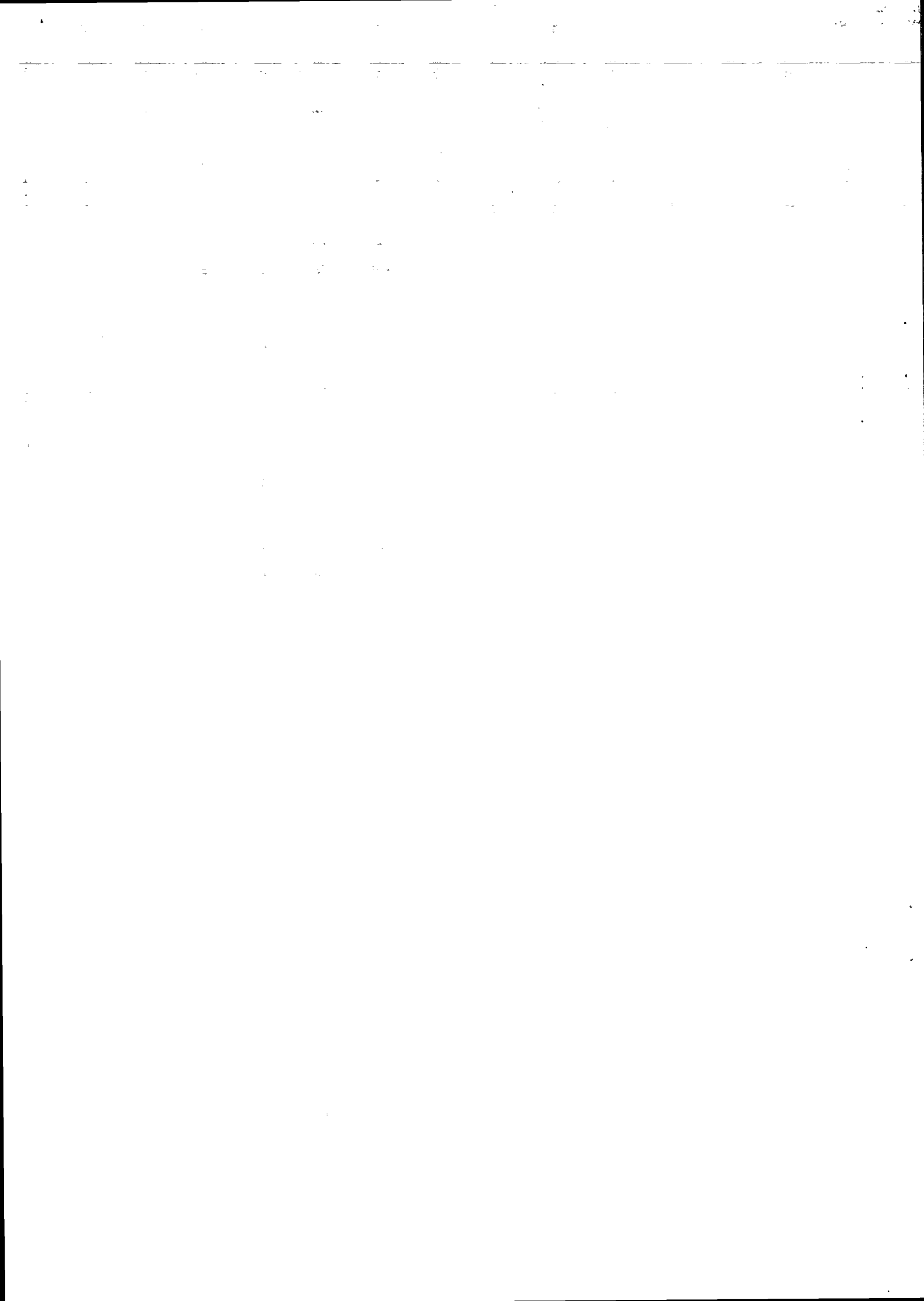

Fig. 9





- 1/78 "TANKER OM EN PRAKSIS" - et matematikprojekt. Projekt rapport af: Anne Jensen, Lena Lindenskov, Marianne Kesselhahn og Nicolai Lomholt. Vejleder: Anders Madsen.
- 2/78 "OPTIMERING" - Menneskets forøgede beherskelsesmuligheder af natur og samfund. Projekt rapport af: Tom J. Andersen, Tommy R. Andersen, Gert Krenøe og Peter H. Lassen. Vejleder: Bernhelm Boss.
- 3/78 "OPCAVESAMLING", breddekursus i fysik. Af: Lasse Rasmussen, Aage Bonde Kræmmer og Jens Højgaard Jensen.
- 4/78 "TRE ESSAYS" - om matematikundervisning, matematiklæreruddannelsen og videnskabsrindalismen. Af: Mogens Niss. Nr. 4 er p.t. udgået.
- 5/78 "BIBLIOGRAFISK VEJLEDNING til studiet af DEN MODERNE FYSIKS HISTORIE". Af: Helge Kragh. Nr. 5 er p.t. udgået.
- 6/78 "NOGLE ARTIKLER OG DEBATINDLÆG OM - læreruddannelse og undervisning i fysik, og - de naturvidenskabelige fags situation efter studenteroprøret". Af: Karin Beyer, Jens Højgaard Jensen og Bent C. Jørgensen.
- 7/78 "MATEMATIKKENS FORHOLD TIL SAMFUNDSØKONOMIEN". Af: B.V. Gnedenko. Nr. 7 er udgået.
- 8/78 "DYNAMIK OG DIAGRAMMER". Introduktion til energy-bond-graph formalismen. Af: Peder Voetmann Christiansen.
- 9/78 "OM PRAKSIS' INDFLYDELSE PÅ MATEMATIKKENS UDVIKLING". - Motiver til Kepler's: "Nova Stereometria Doliorum Vinarium". Projekt rapport af: Lasse Rasmussen. Vejleder: Anders Madsen.
-
- 10/79 "TERMODYNAMIK I GYMNASIET". Projekt rapport af: Jan Christensen og Jeanne Mortensen. Vejledere: Karin Beyer og Peder Voetmann Christiansen.
- 11/79 "STATISTISKE MATERIALER". Af: Jørgen Larsen.
- 12/79 "LINEÆRE DIFFERENTIALLIGNINGER OG DIFFERENTIALLIGNINGSSYSTEMER". Af: Mogens Brun Heefelt. Nr. 12 er udgået.
- 13/79 "CAVENDISH'S FORSØG I GYMNASIET". Projekt rapport af: Gert Kreinøe. Vejleder: Albert Chr. Paulsen.
- 14/79 "BOOKS ABOUT MATHEMATICS: History, Philosophy, Education, Models, System Theory, and Works of". Af: Else Høyrup. Nr. 14 er p.t. udgået.
- 15/79 "STRUKTUREL STABILITET OG KATASTROFER i systemer i og udenfor termodynamisk ligevægt". Specialeopgave af: Leif S. Striegler. Vejleder: Peder Voetmann Christiansen.
- 16/79 "STATISTIK I KRÆFTFORSKNINGEN". Projekt rapport af: Michael Olsen og Jørn Jensen. Vejleder: Jørgen Larsen.
- 17/79 "AT SPØRGE OG AT SVARE i fysikundervisningen". Af: Albert Christian Paulsen.
- 18/79 "MATHEMATICS AND THE REAL WORLD", Proceedings af an International Workshop, Roskilde University Centre, Denmark, 1978. Preprint. Af: Bernhelm Booss og Mogens Niss (eds.)
- 19/79 "GEOMETRI, SKOLE OG VIRKELIGHED". Projekt rapport af: Tom J. Andersen, Tommy R. Andersen og Per H.H. Larsen. Vejleder: Mogens Niss.
- 20/79 "STATISTISKE MODELLER TIL BESTEMMELSE AF SIKRE DOSER FOR CARCINOGENE STOFFER". Projekt rapport af: Michael Olsen og Jørn Jensen. Vejleder: Jørgen Larsen.
- 21/79 "KONTROL I GYMNASIET-FORMÅL OG KONSEKVENSER". Projekt rapport af: Crilles Bacher, Per S. Jensen, Preben Jensen og Torben Nysteen.
- 22/79 "SEMIOTIK OG SYSTEMEGENSKABER (1)". 1-port lineært response og støj i fysikken. Af: Peder Voetmann Christiansen.
- 23/79 "ON THE HISTORY OF EARLY WAVE MECHANICS - with special emphasis on the role of reality". Af: Helge Kragh.
-
- 24/80 "MATEMATIKOPFATTELSE HOS 2.G'ERE". a+b 1. En analyse. 2. Interviewmateriale. Projekt rapport af: Jan Christensen og Knud Lindhardt Rasmussen. Vejleder: Mogens Niss.
- 25/80 "EKSAMENSOPGAVER", Dybdemodulet/fysik 1974-79.
- 26/80 "OM MATEMATISKE MODELLER". En projekt rapport og to artikler. Af: Jens Højgaard Jensen m.fl.
- 27/80 "METHODOLOGY AND PHILOSOPHY OF SCIENCE IN PAUL DIRAC'S PHYSICS". Af: Helge Kragh.
- 28/80 "DILEMTRISK RELAXATION - et forslag til en ny model bygget på væskernes viscoelastiske egenskaber". Projekt rapport af: Gert Kreinøe. Vejleder: Niels Boye Olsen.
- 29/80 "ODIN - undervisningsmateriale til et kursus i differentiaalligningsmodeller". Projekt rapport af: Tommy R. Andersen, Per H.H. Larsen og Peter H. Lassen. Vejleder: Mogens Brun Heefelt.
- 30/80 "FUSIONSENERGIEN - - - ATOMSAMFUNDETS ENDESTATION". Af: Oluf Danielsen. Nr. 30 er udgået.
- 31/80 "VIDENSKABSTEORETISKE PROBLEMER VED UNDERVISNINGSSYSTEMER BASERET PÅ MÆNGDELÆRE". Projekt rapport af: Troels Lange og Jørgen Karrebæk. Vejleder: Stig Andur Pedersen. Nr. 31 er p.t. udgået.
- 32/80 "POLYMERE STOFFERS VISCOELASTISKE EGENSKABER - BELYST VED HJÆLP AF MEKANISKE IMPEDANSMÅLINGER MØSSBAUEREFFEKTMÅLINGER". Projekt rapport af: Crilles Bacher og Preben Jensen. Vejledere: Niels Boye Olsen og Peder Voetmann Christiansen.
- 33/80 "KONSTITUERING AF FAG INDEN FOR TEKNISK - NATURVIDENSKABELIGE UDDANNELSER. I-II". Af: Arne Jakobsen.
- 34/80 "ENVIRONMENTAL IMPACT OF WIND ENERGY UTILIZATION". ENERGY SERIES NO. I. Af: Bent Sørensen. Nr. 34 er udgået.

- 35/80 "HISTORISKE STUDIER I DEN NYERE ATOMFYSIKS UDVIKLING".
Af: Helge Kragh.
- 36/80 "HVAD ER MENINGEN MED MATEMATIKUNDERVISNINGEN?".
Fire artikler.
Af: Mogens Niss.
- 37/80 "RENEWABLE ENERGY AND ENERGY STORAGE".
ENERGY SERIES NO. 2.
Af: Bent Sørensen.
-
- 38/81 "TIL EN HISTORIE TEORI OM NATURERKENDELSE, TEKNOLOGI OG SAMFUND".
Projektrapport af: Erik Gade, Hans Hedal, Henrik Lau og Finn Physant.
Vejledere: Stig Andur Pedersen, Helge Kragh og Ib Thiersen.
Nr. 38 er p.t. udgået.
- 39/81 "TIL KRITIKKEN AF VÆKSTØKONOMIEN".
Af: Jens Højgaard Jensen.
- 40/81 "TELEKOMMUNIKATION I DANMARK - oplæg til en teknologivurdering".
Projektrapport af: Arne Jørgensen, Bruno Petersen og Jan Vedde.
Vejleder: Per Nørgaard.
- 41/81 "PLANNING AND POLICY CONSIDERATIONS RELATED TO THE INTRODUCTION OF RENEWABLE ENERGY SOURCES INTO ENERGY SUPPLY SYSTEMS".
ENERGY SERIES NO. 3.
Af: Bent Sørensen.
- 42/81 "VIDENSKAB TEORI SAMFUND - En introduktion til materialistiske videnskabsopfattelser".
Af: Helge Kragh og Stig Andur Pedersen.
- 43/81 1. "COMPARATIVE RISK ASSESSMENT OF TOTAL ENERGY SYSTEMS".
2. "ADVANTAGES AND DISADVANTAGES OF DECENTRALIZATION".
ENERGY SERIES NO. 4.
Af: Bent Sørensen.
- 44/81 "HISTORISKE UNDERSØGELSER AF DE EKSPERIMENTELLE FORUDSÆNINGER FOR RUTHERFORDS ATOMMODEL".
Projektrapport af: Niels Thor Nielsen.
Vejleder: Bent C. Jørgensen.
-
- 45/82 Er aldrig udkommet.
- 46/82 "EKSEMPLARISK UNDERVISNING OG FYSISK ERKENDELSE-ILLUSTRERET VED TO EKSEMPLER".
Projektrapport af: Torben O. Olsen, Lasse Rasmussen og Niels Dreyer Sørensen.
Vejleder: Bent C. Jørgensen.
- 47/82 "BARSEBÄCK OG DET VÆRST OFFICIELT-TÆNKELIGE UHELD".
ENERGY SERIES NO. 5.
Af: Bent Sørensen.
- 48/82 "EN UNDERSØGELSE AF MATEMATIKUNDERVISNINGEN PÅ ADGANGSKURSUS TIL KØBENHAVNS TEKNIKUM".
Projektrapport af: Lis Ellertzen, Jørgen Karrebæk, Troels Lange, Preben Nørregaard, Lissi Pedersen, Laust Rishøj, Lill Røn og Isac Showiki.
Vejleder: Mogens Niss.
- 49/82 "ANALYSE AF MULTISPEKTRALE SATELLITBILLEDER".
Projektrapport af: Preben Nørregaard.
Vejledere: Jørgen Larsen og Rasmus Ole Rasmussen.
- 50/82 "HERSLEV - MULIGHEDER FOR VEDVARENDE ENERGI I EN LANDSBY".
ENERGY SERIES NO. 6.
Rapport af: Bent Christensen, Bent Hove Jensen, Dennis B. Møller, Bjarne Laursen, Bjarne Lillethorup og Jacob Mørch Pedersen.
Vejleder: Bent Sørensen.
- 51/82 "HVAD KAN DER GØRES FOR AT AFHJÆLPE PICERS BLOKERING OVERFOR MATEMATIK?".
Projektrapport af: Lis Ellertzen, Lissi Pedersen, Lill Røn og Susanne Stender.
- 52/82 "DESUSPENSION OF SPLITTING-ELLIPTIC SYMBOLS".
Af: Bernhelm Booss og Krzysztof Wojciechowski.
- 53/82 "THE CONSTITUTION OF SUBJECTS IN ENGINEERING EDUCATION".
Af: Arne Jacobsen og Stig Andur Pedersen.
- 54/82 "FUTURES RESEARCH" - A Philosophical Analysis of Its Subject-Matter and Methods.
Af: Stig Andur Pedersen og Johannes Witt-Hansen.
- 55/82 "MATEMATISKE MODELLER" - Litteratur på Roskilde Universitetsbibliotek.
En biografi.
Af: Else Høytrup.
Vedr. tekst nr. 55/82 se også tekst nr. 62/83.
- 56/82 "EN - TO - MANGE" -
En undersøgelse af matematisk økologi.
Projektrapport af: Troels Lange.
Vejleder: Anders Madsen.
-
- 57/83 "ASPECT EKSPERIMENTET"-
Skulte variable i kvantemekanikken?
Projektrapport af: Tom Juul Andersen.
Vejleder: Peder Voetmann Christiansen.
Nr. 57 er udgået.
- 58/83 "MATEMATISKE VANDRINGER" - Modelbetragtninger over spredning af dyr mellem småbiotoper i agerlandet.
Projektrapport af: Per Hammershøj Jensen og Lene Vagn Rasmussen.
Vejleder: Jørgen Larsen.
- 59/83 "THE METHODOLOGY OF ENERGY PLANNING".
ENERGY SERIES NO. 7.
Af: Bent Sørensen.
- 60/83 "MATEMATISK MODEKSPERTISE"- et eksempel.
Projektrapport af: Erik O. Gade, Jørgen Karrebæk og Preben Nørregaard.
Vejleder: Anders Madsen.
- 61/83 "FYSIKS IDEOLOGISKE FUNKTION, SOM ET EKSEMPEL PÅ EN NATURVIDENSKAB - HISTORISK SET".
Projektrapport af: Annette Post Nielsen.
Vejledere: Jens Høytrup, Jens Højgaard Jensen og Jørgen Vogeliuss.
- 62/83 "MATEMATISKE MODELLER" - Litteratur på Roskilde Universitetsbibliotek.
En biografi 2. rev. udgave.
Af: Else Høytrup.
- 63/83 "CREATING ENERGY FUTURES: A SHORT GUIDE TO ENERGY PLANNING".
ENERGY SERIES No. 8.
Af: David Crossley og Bent Sørensen.
- 64/83 "VON MATEMATIK UND KRIEG".
Af: Bernhelm Booss og Jens Høytrup.
- 65/83 "ANVENDT MATEMATIK - TEORI ELLER PRAKSIS".
Projektrapport af: Per Hedegård Andersen, Kirsten Habekost, Carsten Holst-Jensen, Annelise von Moos, Else Marie Pedersen og Erling Møller Pedersen.
Vejledere: Bernhelm Booss og Klaus Grünbaum.
- 66/83 "MATEMATISKE MODELLER FOR PERIODISK SELEKTION I ESCHERICHIA COLI".
Projektrapport af: Hanne Lisbet Andersen, Ole Richard Jensen og Klavs Frisdahl.
Vejledere: Jørgen Larsen og Anders Hede Madsen.
- 67/83 "ELEPSOIDE METODEN - EN NY METODE TIL LINEÆR PROGRAMMERING?".
Projektrapport af: Lone Billmann og Lars Boye.
Vejleder: Mogens Brun Heefelt.
- 68/83 "STOKASTISKE MODELLER I POPULATIONSGENETIK" - til kritikken af teoriladede modeller.
Projektrapport af: Lise Odgård Gade, Susanne Hansen, Michael Hviid og Frank Mølgård Olsen.
Vejleder: Jørgen Larsen.

- 69/83 "ELEVFORUDSÆTNINGER I FYSIK"
- en test i l.g med kommentarer.
Af: Albert C. Paulsen.
- 70/83 "INDLÆRINGS - OG FORMIDLINGSPROBLEMER I MATEMATIK PÅ VOKSENUNDERVISNINGSNIVEAU".
Projektrapport af: Hanne Lisbet Andersen, Torben J. Andreasen, Svend Åge Houmann, Helle Glerup Jensen, Keld Fl. Nielsen, Lene Vagn Rasmussen.
Vejleder: Klaus Grünbaum og Anders Hede Madsen.
- 71/83 "PIGER OG FYSIK"
- et problem og en udfordring for skolen?
Af: Karin Beyer, Sussann Blegaa, Birthe Olsen, Jette Reich og Mette Vedelsby.
- 72/83 "VERDEN IFØLGE PEIRCE" - to metafysiske essays, om og af C.S Peirce.
Af: Peder Voetmann Christiansen.
- 73/83 ""EN ENERGIANALYSE AF LANDBRUG"
- økologisk contra traditionelt.
ENERGY SERIES NO. 9
Specialeopgave i fysik af: Bent Hove Jensen.
Vejleder: Bent Sørensen.
-
- 74/84 "MINIATURISERING AF MIKROELEKTRONIK" - om videnskabeliggjort teknologi og nytten af at lære fysik.
Projektrapport af: Bodil Harder og Linda Szkotak Jensen.
Vejledere: Jens Højgaard Jensen og Bent C. Jørgensen.
- 75/84 "MATEMATIKUNDERVISNINGEN I FREMTIDENS GYMNASIUM"
- Case: Lineær programmering.
Projektrapport af: Morten Blomhøj, Klavs Frisdahl og Frank Mølgaard Olsen.
Vejledere: Mogens Brun Heefelt og Jens Bjørneboe.
- 76/84 "KERNEKRAFT I DANMARK?" - Et hørings svar indkaldt af miljøministeriet, med kritik af miljøstyrelsens rapporter af 15. marts 1984.
ENERGY SERIES No. 10
Af: Niels Boye Olsen og Bent Sørensen.
- 77/84 "POLITISKE INDEKS - FUP ELLER FAKTA?"
Opinionsundersøgelser belyst ved statistiske modeller.
Projektrapport af: Svend Åge Houmann, Keld Nielsen og Susanne Stender.
Vejledere: Jørgen Larsen og Jens Bjørneboe.
- 78/84 "JÆVSTRØMSLEDNINGSEVNE OG GITTERSTRUKTUR I AMORFT GERMANIUM".
Specialrapport af: Hans Heddal, Frank C. Ludvigsen og Finn C. Physant.
Vejleder: Niels Boye Olsen.
- 79/84 "MATEMATIK OG ALMENDANNELSE".
Projektrapport af: Henrik Coster, Mikael Wennerberg Johansen, Povl Kattler, Birgitte Lydholm og Morten Overgaard Nielsen.
Vejleder: Bernhelm Booss.
- 80/84 "KURSUSMATERIALE TIL MATEMATIK B".
Af: Mogens Brun Heefelt.
- 81/84 "FREKVENSafhængig ledningsevne i amorft germanium".
Specialrapport af: Jørgen Wind Petersen og Jan Christensen.
Vejleder: Niels Boye Olsen.
- 82/84 "MATEMATIK - OG FYSIKUNDERVISNINGEN I DET AUTO - MATISEREDE SAMFUND".
Rapport fra et seminar afholdt i Hvidovre 25-27 april 1983.
Red.: Jens Højgaard Jensen, Bent C. Jørgensen og Mogens Niss.
- 83/84 "ON THE QUANTIFICATION OF SECURITY":
PEACE RESEARCH SERIES NO. 1
Af: Bent Sørensen
nr. 83 er p.t. udgået
- 84/84 "NOGLE ARTIKLER OM MATEMATIK, FYSIK OG ALMENDANNELSE".
Af: Jens Højgaard Jensen, Mogens Niss m. fl.
- 85/84 "CENTRIFUGALREGULATORER OG MATEMATIK".
Specialrapport af: Per Hedegård Andersen, Carsten Holst-Jensen, Else Marie Pedersen og Erling Møller Pedersen.
Vejleder: Stig Andur Pedersen.
- 86/84 "SECURITY IMPLICATIONS OF ALTERNATIVE DEFENSE OPTIONS FOR WESTERN EUROPE".
PEACE RESEARCH SERIES NO. 2
Af: Bent Sørensen.
- 87/84 "A SIMPLE MODEL OF AC HOPPING CONDUCTIVITY IN DISORDERED SOLIDS".
Af: Jeppe C. Dyre.
- 88/84 "RISE, FALL AND RESURRECTION OF INFINITESIMALS".
Af: Detlef Laugwitz.
- 89/84 "FJERNVARMEOPTIMERING".
Af: Bjarne Lillethorup og Jacob Mørch Pedersen.
- 90/84 "ENERGI I L.G - EN TEORI FOR TILRETTELÆGGELSE".
Af: Albert Chr. Paulsen.
-
- 91/85 "KVANTETEORI FOR GYMNASIET".
1. Lærervejledning
Projektrapport af: Biger Lundgren, Henning Sten Hansen og John Johansson.
Vejleder: Torsten Meyer.
- 92/85 "KVANTETEORI FOR GYMNASIET".
2. Materiale
Projektrapport af: Biger Lundgren, Henning Sten Hansen og John Johansson.
Vejleder: Torsten Meyer.
- 93/85 "THE SEMIOTICS OF QUANTUM - NON - LOCALITY".
Af: Peder Voetmann Christiansen.
- 94/85 "TREENIGHEDEN BOURBAKI - generalen, matematikeren og ånden".
Projektrapport af: Morten Blomhøj, Klavs Frisdahl og Frank M. Olsen.
Vejleder: Mogens Niss.
- 95/85 "AN ALTERNATIV DEFENSE PLAN FOR WESTERN EUROPE".
PEACE RESEARCH SERIES NO. 3.
Af: Bent Sørensen
- 96/85 "ASPEKTER VED KRAFTVARMEFORSYNING".
Af: Bjarne Lillethorup.
Vejleder: Bent Sørensen.
- 97/85 "ON THE PHYSICS OF A.C. HOPPING CONDUCTIVITY".
Af: Jeppe C. Dyre.
- 98/85 "VALGMULIGHEDER I INFORMATIONSAALDEREN".
Af: Bent Sørensen.
- 99/85 "Der er langt fra Q til R".
Projektrapport af: Niels Jørgensen og Mikael Klintorp.
Vejleder: Stig Andur Pedersen.
- 100/85 "TALSYSTEMETS OPBYGNING".
Af: Mogens Niss.
- 101/85 "EXTENDED MOMENTUM THEORY FOR WINDMILLS IN PERIURBATIVE FORM".
Af: Ganesh Sengupta.
- 102/85 OPSTILLING OG ANALYSE AF MATEMATISKE MODELLER, BELYST VED MODELLER OVER KØRS FODEROPTAGELSE OG - OMSÆTNING".
Projektrapport af: Lis Eilertzen, Kirsten Habekost, Lill Røn og Susanne Stender.
Vejleder: Klaus Grünbaum.

- 103/85 "ØDSLE KOLDKRIGERE OG VIDENSKABENS LYSE IDEER".
 Projekt rapport af: Niels Ole Dam og Kurt Jensen.
 Vejleder: Bent Sørensen.
- 104/85 "ANALOGREGNEMASKINEN OG LORENZLIGNINGER".
 Af: Jens Jäger.
- 105/85 "THE FREQUENCY DEPENDENCE OF THE SPECIFIC HEAT OF THE GLASS REANSITION".
 Af: Tage Christensen.
 "A SIMPLE MODEL OF AC HOPPING CONDUCTIVITY".
 Af: Jeppe C. Dyre.
 Contributions to the Third International Conference on the Structure of Non - Crystalline Materials held in Grenoble July 1985.
- 106/85 "QUANTUM THEORY OF EXTENDED PARTICLES".
 Af: Bent Sørensen.
- 107/85 "EN MYG GØR INGEN EPIDEMI".
 - flodblindhed som eksempel på matematisk modellering af et epidemiologisk problem.
 Projekt rapport af: Per Hedegård Andersen, Lars Boye, Carsten Holst Jensen, Else Marie Pedersen og Erling Møller Pedersen.
 Vejleder: Jesper Larsen.
- 108/85 "APPLICATIONS AND MODELLING IN THE MATHEMATICS CURRICULUM" - state and trends -
 Af: Mogens Niss.
- 109/85 "COX I STUDIE TIDEN" - Cox's regressionsmodel anvendt på studenteroplysninger fra RUC.
 Projekt rapport af: Mikael Wennerberg Johansen, Poul Kattler og Torben J. Andreasen.
 Vejleder: Jørgen Larsen.
- 110/85 "PLANNING FOR SECURITY".
 Af: Bent Sørensen
- 111/85 "JORDEN RUNDT PÅ FLADE KORT".
 Projekt rapport af: Birgit Andresen, Beatriz Quinones og Jimmy Staal.
 Vejleder: Mogens Niss.
- 112/85 "VIDENSKABELIGGØRELSE AF DANSK TEKNOLOGISK INNOVATION FREM TIL 1950 - BELYST VED EKSEMPLER".
 Projekt rapport af: Erik Odgaard Gade, Hans Hedal, Frank C. Ludvigsen, Annette Post Nielsen og Finn Physant.
 Vejleder: Claus Bryld og Bent C. Jørgensen.
- 113/85 "DESUSPENSION OF SPLITTING ELLIPTIC SYMBOLS 11".
 Af: Bernhelm Booss og Krzysztof Wojciechowski.
- 114/85 "ANVENDELSE AF GRAFISKE METODER TIL ANALYSE AF KONTIGENSTABELLER".
 Projekt rapport af: Lone Billmann, Ole R. Jensen og Arne-Lise von Moos.
 Vejleder: Jørgen Larsen.
- 115/85 "MATEMATIKKENS UDVIKLING OP TIL RENESSANCEN".
 Af: Mogens Niss.
- 116/85 "A PHENOMENOLOGICAL MODEL FOR THE MEYER-NELDEL RULE".
 Af: Jeppe C. Dyre.
- 117/85 "KRAFT & FJERNVARMEOPTIMERING".
 Af: Jacob Mørch Pedersen.
 Vejleder: Bent Sørensen
- 118/85 "TILFÆLDIGHEDEN OG NØDVENDIGHEDEN IFØLGE PEIRCE OG FYSIKKEN".
 Af: Peder Voetmann Christiansen
- 120/86 "ET ANVAT STATISTISKE STANDARDMODELLER".
 Af: Jørgen Larsen
- 121/86 "SIMULATION I KONTINUERT TID".
 Af: Peder Voetmann Christiansen.
- 122/86 "ON THE MECHANISM OF GLASS IONIC CONDUCTIVITY".
 Af: Jeppe C. Dyre.
- 123/86 "GYMNASIEFYSIKKEN OG DEN STORE VERDEN".
 Fysiklærerforeningen, IMFUFA, RUC.
- 124/86 "OPGAVESAMLING I MATEMATIK".
 Samtlige opgaver stillet i tiden 1974-jan. 1986.
- 125/86 "UVBY, 8 - systemet - en effektiv fotometrisk spektral-klassifikation af B-, A- og F-stjerner".
 Projekt rapport af: Birger Lundgren.
- 126/86 "OM UDVIKLINGEN AF DEN SPECIELLE RELATIVITETSTEORI".
 Projekt rapport af: Lise Odgaard & Linda Szkotak Jensen
 Vejledere: Karin Beyer & Stig Andur Pedersen.
- 127/86 "GALOIS' BIDRAG TIL UDVIKLINGEN AF DEN ABSTRAKTE ALGEBRA".
 Projekt rapport af: Pernille Sand, Heine Larsen & Lars Frandsen.
 Vejleder: Mogens Niss.
- 128/86 "SMÅKRYB" - en ikke-standard analyse.
 Projekt rapport af: Niels Jørgensen & Mikael Klintorp.
 Vejleder: Jeppe Dyre.
- 129/86 "PHYSICS IN SOCIETY"
 Lecture Notes 1983 (1986)
 Af: Bent Sørensen
- 130/86 "Studies in Wind Power"
 Af: Bent Sørensen
- 131/86 "FYSIK OG SAMFUND" - Et integreret fysik/historie-projekt om naturanskuelsens historiske udvikling og dens samfundsmæssige betingethed.
 Projekt rapport af: Jakob Heckscher, Søren Brønd, Andy Wierød.
 Vejledere: Jens Høyrup, Jørgen Vogelius, Jens Højgaard Jensen.
- 132/86 "FYSIK OG DANNEELSE"
 Projekt rapport af: Søren Brønd, Andy Wierød.
 Vejledere: Karin Beyer, Jørgen Vogelius.
- 133/86 "CHERNOBYL ACCIDENT: ASSESSING THE DATA. ENERGY SERIES NO. 15.
 Af: Bent Sørensen.
-
- 134/87 "THE D.C. AND THE A.C. ELECTRICAL TRANSPORT IN AsSeTe SYSTEM"
 Authors: M.B.El-Den, N.B.Olsen, Ib Høst Pedersen, Petr Visčor
- 135/87 "INTUITIONISTISK MATEMATIKS METODER OG ERKENDELSESTEORETISKE FORUDSÆTNINGER"
 MATEMATIKSPECIALE: Claus Larsen
 Vejledere: Anton Jensen og Stig Andur Pedersen
- 136/87 "Mystisk og naturlig filosofi: En skitse af kristendommens første og andet møde med græsk filosofi"
 Projekt rapport af Frank Colding Ludvigsen
 Vejledere: Historie: Ib Thiersen
 Fysik: Jens Højgaard Jensen
- 137/87 "HOPMODELLER FOR ELEKTRISK LEDNING I UORDNEDE FASTE STOFFER" - Resume af licentiatforhandling
 Af: Jeppe Dyre
 Vejledere: Niels Boye Olsen og Peder Voetmann Christiansen.
- 119/86 "DET ER GANSKE VIST -- EUKLIDS FEMTE POSTULAT KUNNE NOK SKABE RØRE I ANDEDAMMEN".
 Af: Iben Maj Christiansen
 Vejleder: Mogens Niss.

138/87 "JOSEPHSON EFFECT AND CIRCLE MAP."
Paper presented at The International
Workshop on Teaching Nonlinear Phenomena
at Universities and Schools, "Chaos in
Education". Balaton, Hungary, 26 April-2 May 1987.
By: Peder Voetmann Christiansen

152/87 "PSEUDO-DIFFERENTIAL PROJECTIONS AND THE TOPOLOGY
OF CERTAIN SPACES OF ELLIPTIC BOUNDARY VALUE
PROBLEMS"

by: Bernhelm Booss-Bavnbek
Krzysztof P. Wojciechowski

139/87 "Machbarkeit nichtbeherrschbarer Technik
durch Fortschritte in der Erkennbarkeit
der Natur"
Af: Bernhelm Booss-Bavnbek
Martin Bohle-Carbonell

140/87 "ON THE TOPOLOGY OF SPACES OF HOLOMORPHIC MAPS"
By: Jens Gravesen

141/87 "RADIOMETERS UDVIKLING AF BLODGASAPPARATUR -
ET TEKNOLOGIHISTORISK PROJEKT"
Projektrapport af Finn C. Physant
Vejleder: Ib Thiersen

142/87 "The Calderón Projektor for Operators With
Splitting Elliptic Symbols"
by: Bernhelm Booss-Bavnbek og
Krzysztof P. Wojciechowski

143/87 "Kursusmateriale til Matematik på NAT-BAS"
af: Mogens Brun Heefelt

144/87 "Context and Non-Locality - A Peircan Approach
Paper presented at the Symposium on the
Foundations of Modern Physics The Copenhagen
Interpretation 60 Years after the Como Lecture.
Joensuu, Finland, 6 - 8 august 1987.
By: Peder Voetmann Christiansen

145/87 "AIMS AND SCOPE OF APPLICATIONS AND
MODELLING IN MATHEMATICS CURRICULA"
Manuscript of a plenary lecture delivered at
ICMTA 3, Kassel, FRG 8.-11.9.1987
By: Mogens Niss

146/87 "BESTEMMELSE AF BULKRESISTIVITETEN I SILICIUM"
- en ny frekvensbaseret målemetode.
Fysikspeciale af Jan Vedde
Vejledere: Niels Boye Olsen & Petr Višćor

147/87 "Rapport om BIS på NAT-BAS"
redigeret af: Mogens Brun Heefelt

148/87 "Naturvidenskabsundervisning med
Samfundsperspektiv"
af: Peter Colding-Jørgensen DLH
Albert Chr. Paulsen

149/87 "In-Situ Measurements of the density of amorphous
germanium prepared in ultra high vacuum"
by: Petr Višćor

150/87 "Structure and the Existence of the first sharp
diffraction peak in amorphous germanium
prepared in UHV and measured in-situ"
by: Petr Višćor

151/87 "DYNAMISK PROGRAMMERING"
Matematikprojekt af:
Birgit Andresen, Keld Nielsen og Jimmy Staal
Vejleder: Mogens Niss